

## APPLICATION

- To close impulse piping if it is necessary to disconnect pressure difference sensor or pressure difference sensor and interconnect both inlet pressures when adjusting zero of the pressure difference sensor at operation pressure;
- For venting (draining) and inspection (test) of the sensor;
- As selected equipment BT2 and BT3 pursuant to the Decree No. 214/1997 Coll., on securing quality at activities related with the use of nuclear energy and activities resulting in radiation exposure and on identification of criteria for classification and division of selected equipment into safety classes;
- As pressure equipment of category III pursuant to the Decree of the Government 26/2003 Coll. (compliance assessment module B+D);
- As special design in the grade of purity for oxygen (code P2S);
- As special design with cleanness of internal surfaces of grade I pursuant to TPE 10-40/1926/85 (code PC1);
- For the environment requiring seismic resistance 1 Hz to 33 Hz, acceleration 3g, certificate of STKC Dubnica.

The valves are rated products pursuant to the Act No. 22/1997 Coll. and the Declaration of Conformity **EC-964000** is issued for them.

## DESCRIPTION

The basis of valves consists of a body, into which a valve unit is screwed. Its seat is a part of the basic body of the armature. In case of the armature with soft sealing, the seat has a special shape, which contributes to ensuring perfect tightness. Material of the basic body is steel 1.4541.

Valve units have different designs pursuant to the type of used spindle sealing. It can be formed by elastomer o-ring or seal from graphite or from a plastic material.

### Valve unit with elastomer o-ring

Position	Part	Material
1	Valve unit body	1.4541 *)
2	Spindle	1.4541 *)
3	Handle	1.4541 *)
4	O-ring	FPM (code W1) NBR (code W2) EPDM (code W3)
5	Support ring	PTFE
6	Seat sealing	1.4571 (code S1) *) Si <sub>3</sub> N <sub>4</sub> (code S2) PVDF (code S3)
7	Differentiating ring	PVC
8	Sealing hole	

\*) with respect to this material, the manufacturer has certificate 3.1 pursuant to ČSN EN 10204

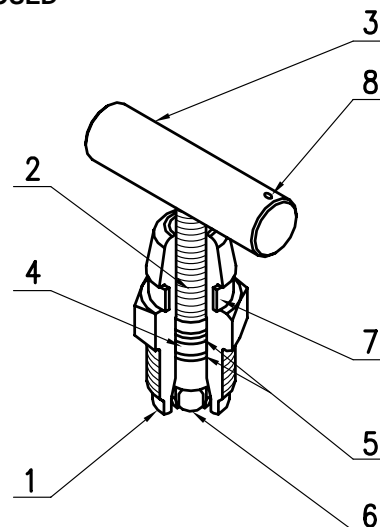

### Valve unit with seal from graphite, PTFE or PEEK

Position	Part	Material
1	Valve unit body	1.4541 *)
2	Spindle	1.4541 *)
3	Handle	1.4541 *)
4	Lid of sealing	1.4541 *)
5	Safety nut	1.4541 *)
6	Ring	1.4541 *)
7	Support ring for spindle seal sealing	(W4) 1.4541 *)
		(W5) PVDF
		(W7) PEEK
8	Spindle seal sealing	CHARTITE (code W4) PTFE (code W5) PEEK (code W6) PTFE (code W7)
9	Seat sealing	1.4571 (code S1) *) Si <sub>3</sub> N <sub>4</sub> (code S2) PVDF (code S3)
10	Differentiating ring	PVC (not for code W4)
11	Sealing hole	

\*) with respect to this material, the manufacturer has certificate 3.1 pursuant to ČSN EN 10204

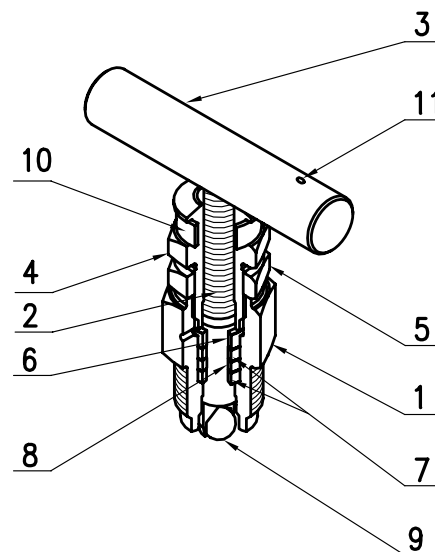

By turning the control handle to the right (left) up to the stop, the flow of the operation liquid through the armature body is closed (opened).

**TECHNICAL DATA**

Technical requirements for valve sets and dimensions of connecting terminals are specified in ČSN 13 7501, connecting dimensions of manometric valve comply with ČSN 13 7517.

**Operation position:** discretionary  
**Weight:** approx. 0.4 kg  
**Type of operation:** continuous

**OPERATION CONDITIONS**

The armatures are designed for the environment defined by the group of parameters and their severity grades IE36 pursuant to standard ČSN EN 60 721-3-3 and the following operation conditions.

**PRESSURE AND TEMPERATURE CHARACTERISTICS**

Values of pressure and temperature of operation medium, for which the armature may be used, are determined, in particular, by the selected material of spindle sealing and sealing elements of valve unit seats. The charts provide dependency of pressure on temperature for various materials of such sealing elements. When selecting the material, it is necessary to consider both the chart for the spindle sealing material and the chart for seat sealing material. Operation characteristics of the armature are determined by the material with worse parameters.

Chart 1

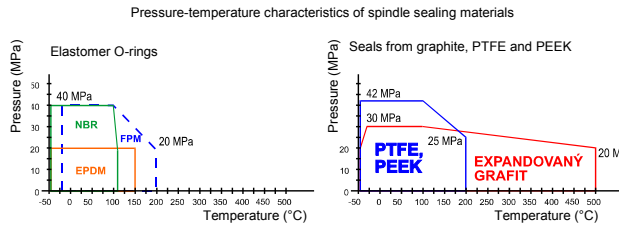

Chart 2

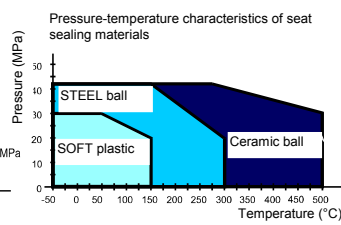
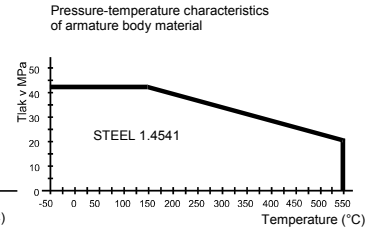

Chart 3



**TABLE 1 - RESULTING MAXIMUM VALUES OF OPERATION PRESSURES AND TEMPERATURES** (they are marked on the armature body)

CODE	W1 (FPM)	W2 (NBR)	W3 (EPDM)	W4 (CHARTIT+1.4541)	W5 (PTFE+PVDF) W6 (PEEK)	W7 (PTFE+PEEK)
S1 (STEEL)	40 MPa 100°C 20 MPa 200°C	40 MPa 100°C 20 MPa 110°C	20 MPa 150°C	30 MPa 100°C 20 MPa 300°C	42 MPa 100°C 25 MPa 200°C	15 MPa 260°C 25 MPa 100°C
S2 (CERAMICS)	40 MPa 100°C 20 MPa 200°C	40 MPa 100°C 20 MPa 110°C	20 MPa 150°C	30 MPa 100°C 20 MPa 500°C	42 MPa 100°C 25 MPa 200°C	15 MPa 260°C 25 MPa 100°C
S3 (PLASTIC MATERIAL)	20 MPa 150°C	20 MPa 110°C	20 MPa 150°C	NOT	20 MPa 150°C	NOT

**TABLE 2 - CHEMICAL RESISTANCE OF SEALING MATERIALS**

Chemical resistance of materials of sealing elements represents an important parameter, which determines reliability of the valve. The following table includes informative data of the most frequently used substances together with chemical resistance of sealing element materials. If other substances are used, chemical resistance tests shall be performed directly at the customer in the expected operation conditions (temperature, pressure, concentration ...)

Medium		FPM	NBR	EPDM	CHARTITE	PTFE	PEEK	PVDF	
Acetone		-	-	-	+	+	+	*	
Acetylene		+	+	+	+	+	+	+	
Petrol		+	*	-	+	+	+	+	
Ammonia	aqueous solution	-	-	+	+	+	+	+	
	liquid	-	*	+	+	+			
	gaseous	*	*	-	+	+			
Ethylene		+	+	+	+	+			
Hydraulic fluids	not flammable	*	-	+	+	+	+		
Hydroxides		*	*	+	+	+	+		
ACIDS	Boric	+	+	+		+	+	+	
	Citric	+	*	+		+	+	+	
	Nitric	-	-	-	+	+	+	+	
	Hydrofluoric	< 65%	*	-	*	+	+	-	+
		> 65%	*	-	*		+	-	
	Phosphoric	10%	+	+	+	+	+	+	+
		concentrate	+	+	+		+	+	+
		boiling conc.	+	-	+		+	*	
	Hydrochloric	10%, 80°C	*	-	+		+	+	+
		36%, 20°C	*	*	+		+	+	+
	Chromic		+	-	*		+		
	Malic		+	+	+		+		+
	Carbolic		-	-	-		+		
	Hydrocyanic		+	*	*		+		
	Butyric		*	*			+		
	Lactic		+	*	+		+	+	+
	Formic	10%	-	-	*	+	+	+	+
		concentrate	-	-	-		+	-	
	Salicylic		+	+	+		+		+
	Sulphuric	25%	*	*	+	+	+	+	+
80%		-	-	*	+	+	-	*	
Oxalic	10%	+	+	+		+	+	+	

	Carbonic		+	+	+	+	+	+	+
	Tartaric		+	+	+	+	+	+	+
	Oxygen		+	-	+	+	+	+	+
	Oils		+	*	-	+	+	+	+
	Steam	< 200°C	*	-	*	+	+	+	
		> 200°C	-	-	-	+	-		-
	Perchloroethylene		+	*	-	+	+	+	+
	Kerosene		+	*	-	+	+	+	+
	Gaseous fuels		+	+	-	+	+	+	+
	Radioactive radiation		*	*	*	*	-	+	-
	Compressed air		+	+	+	+	+		+
	Toluene, trichloroethylene		*	-	-	+		+	+
	Hydrocarbons		+	+	-	+	+		+
	Water	< 80°C	+	+	+	+	+	+	+
		> 80°C	+	*	+	+	+	+	+
	Hydrogen	cold	+	+	+	+	+	+	+
		hot	+	*	+	+	+	+	+

+ great resistance  
 \* good or conditional resistance  
 - not resistant  
 vacant no information is available

**DESIGNATION**

(pursuant to ČSN 13 3005-1)

**Data on basic body**

- Trade mark of the manufacturer
- Maximum operation pressures and temperatures
- Body material
- Casting number of material of basic body
- Scheme of the set
- Mark of performed pressure test
- Arrow indicating recommended direction of flow of medium
- Product ordering number
- Time code  
 (manufacturing number for orders pursuant to the Decree 214/1997 Coll., for design for O<sub>2</sub> and design with code PC1)
- Mark CE 1015

**Data on valve unit**

- Designation of function of valve unit

TEXT	COLOUR	FUNCTION
BLOCK	blue	closing
EQUALIZE	green	balancing (interconnecting)
VENT	red	venting / draining

- As for designs W2, W3, W4, W5, W6, W7, S2 and S3, these codes are marked on the surface of the hexagon of each valve unit;
- The armature in purity level for O<sub>2</sub> is marked with a suspended blue tag

**DELIVERY**

Unless agreed otherwise with the customer, each delivery includes

- Delivery note
- Products pursuant to the purchase order
- Sealing rings 24 x 18 x 3 (only for design 964 2xxx and 964 3xxx)
- Holder B3 (only for design 964 4xxx)
- Optional accessories pursuant to manual for accessories, type 981
- Accompanying technical documentation in Czech:
  - o Product quality and completeness certificate, which also serves as the warranty certificate
  - o EC Declaration of Conformity
  - o Test report and list of used materials
  - o Product manual
  - o Manual for accessories, type 981
  - o Inspection report for design for O<sub>2</sub> (only in case of armature with code P2S)
  - o Inspection report about purity of internal surfaces (only in case of armature with code PC1)

If it is established in the purchase contract or agreed otherwise, the following documentation can be also delivered with the product:

- Copy of EC-Type Examination certificate pursuant to the Decree of the Government 26/2003 Coll.
- Copy of inspection certificate 3.1 pursuant to ČSN EN 10204 for body material with casting number

- Declaration of Conformity with purchase order 2.1 pursuant to ČSN EN 10204
- Copy of certificate of test results for verification of seismic capability pursuant to ČSN IEC 980

**CERTIFICATION**

- Pressure equipment of category III pursuant to the Decree of the Government 26/2003 Coll. (compliance assessment module B+D), EC-Type Examination Certificate SZÚ Brno

**PACKING**

Both products and accessories are delivered in a packing ensuring resistance to the impact of thermal effects and mechanical effects pursuant to controlled packing regulations. When removing the product from the packing, no special measures are necessary with the exception of design for O<sub>2</sub>, when perfect degreasing of the product shall be maintained.

**TRANSPORT**

The products may be transported on conditions corresponding to the set of combinations of classes IE 21 pursuant to ČSN EN 60721-3-2 (i.e. by airplanes and trucks, in premises that are ventilated and protected against atmospheric conditions).

**STORAGE**

The products may be stored on conditions corresponding to the set of combinations of classes IE 11/1K3 pursuant to ČSN EN 60721-3-1 (i.e. in places with temperature from -5 to 45 °C and humidity from 5 to 95%, without a special threat of an attack with biological agents, with vibrations of small significance and not situated close to sources of dust and sand).

**PLACING AN ORDER**

The purchase order shall specify:

- Name
- Product ordering number
- Other (special) requirements
- Number of pieces

**PURCHASE ORDER EXAMPLE**

**Standard design:**

1. Valve set  
9644521  
20 pcs
2. Valve set  
9644521W4S2  
20 pcs
3. Valve set  
9642452W6S1PC1  
20 pcs
4. Valve set  
964411515  
20 pcs
5. Valve set  
9644515W4S2AS21

- 20 pcs
- 6. Valve set  
964415115FR  
20 pcs

**Special requirement:**  
Valve set  
964221212  
20 pcs

**TABLE 3 - DESIGN OF VALVE SETS, TYPE 964**

SPECIFICATIONS				ORDERING NUMBER								
				964	x	x	x	x	x	x	vol. <sup>3)</sup>	aces. <sup>4)</sup>
INSTALLATION OF SET	conventional to sensor flange - pitch 54mm			2								
	conventional to sensor flange - pitch 57mm <sup>7)</sup>			3								
	between impulse piping - pitch 54mm			4								
DESIGN OF SET	two-way - fixation in one place				1							
	two-way - fixation in two places <sup>7)</sup>				2							
	three-way				3							
	three-way with venting valves				4							
	five-way				5							
CONNECTING TERMINALS pursuant to manual for accessories, type 981		OF INLET <sup>1)</sup>					x	x				
		OF OUTLET <sup>2)</sup>							x	x		
SPINDLE SEALING	O-ring from elastomer FPM (max. 200°C)										W1	
	O-ring from elastomer NBR (max. 110°C)										W2	
	O-ring from elastomer EPDM (max. 150°C)										W3	
	seal Chartite + 1.4541 (max. 500°C)										W4	
	seal PTFE + PVDF (max. 200°C)										W5	
	seal PEEK (resistant to gamma radiation) (max. 200°C)										W6	
	seal PTFE + PEEK (max. 260°C)										W7	
SEAT SEALING	stainless ball from mat. 1.4571 (max. 300°C)										S1	
	ceramic ball Si <sub>3</sub> N <sub>4</sub> (standard for W4) (max. 500°C)										S2	
	soft sealing PVDF (NOT for W4, W7) (max.150°C)										S3	
SPECIAL TREATMENT	purity grade for O <sub>2</sub> (NOT for W4)										P2S	
	cleanness of internal surfaces of the equipment, grade I										PC1	
INSTALLATION ON PRESSURE DIFFERENCE SENSOR FISCHER ROSEMOUNT 3051 <sup>5)</sup>		(only for 964.3..., 964.4..., 964.5..)									FR	
ANOTHER SCHEME OF SET		(only for 964 25..., 964 45..)	Control measurement <sup>6)</sup>	NO							AS1 AS2	
				YES								AS01 AS11 AS21

- 1) With respect to the design between impulse piping, the terminals at outlet of the set are equal with terminals at the inlet (with the exception of 964 41...). It is possible to select terminals with the following codes: 11, 12, 13, 14, 15, 21, 22, 31, 32, 33, 34, 35, 36, 37, 38, 39, 41, 42, 43, 51, 54, 61 and 63.
- 2) Only for two-way design 964 41x xxx, it is possible to select other connecting terminals at the inlet and outlet with the following codes 11, 12, 13, 14, 15, 21, 22, 31, 32, 33, 34, 35, 36, 37, 38, 41, 42, 43, 51, 52, 61 and 63. For code 52 at the outlet, it is only possible to use code 52 at the inlet.
- 3) Codes behind numerical designation (position vol.) mark either other than standard design, spec. treatment or other scheme of the set. In case none of such codes is specified, the set will be delivered with standard design, i.e. with sealing W1 and S1.
- 4) Behind the ordering number, it is possible to add codes of accessories pursuant to manual for accessories, type 981: ODP1, ODP2, KL1, KU1 to KU6, NA1 to NA6, NAG1 to NAG6, EMA3, TZ1  
In case the code KU or NA is specified, all delivered cones or sleeves are equal. If different terminals are required (e.g. carbon steel for inlet, stainless steel for outlet, or different diameters), they shall be ordered separately pursuant to manual for accessories, type 981  
Codes of accessories, which may be specified behind the ordering number only for design 964 2xxx and 964 3xxx: SR2, SR3, SR4, SR 5, B3
- 5) Specification of sensor and possible venting quick coupler EMA3 shall be specified by the customer in the purchase order  
Pressure sensor FR 3051 + quick couplers EMA3 may be delivered by the customer.
- 6) The terminal with code 51 is used for inspection measurement as a default, code 53 only for design 9642553AS2 or 9642553AS21
- 7) Only as a special requirement after an agreement with the manufacturer.

TABLE 4 – LIST OF DRAWINGS OF VALVE SET DESIGNS

No. of figure	Design of set	Installation of set	Ordering number (part)	Scheme of set	Weight approx. [kg]		
1.	Two-way fixation in one place	On conventional or coplanar flange of the sensor	964 21 ..		1.3		
2.			964 22 .. *)		2.2		
3.			964 41 ..		1.3		
4.	Three-way without venting	On conventional or coplanar flange of the sensor - pitch 54 mm (57 mm)	964 23 .. 964 33 .. *)		2.2		
5.			964 43 ..		1.5		
6.		with venting valve	On conventional or coplanar flange of the sensor - pitch 54 mm (57 mm)	964 24 .. 964 34 .. *)		2.5	
7.				964 44 ..		2.3	
8.	Five-way without inspection measurement	On conventional or coplanar flange of the sensor – pitch 54 mm (57 mm)	964 25 .. 964 35 .. *)		2.3		
9.			964 25 .. AS1		2.3		
10.			964 25 .. AS2		2.3		
11.		with inspection measurement	On conventional or coplanar flange of the sensor – pitch 54 mm	964 25 .. AS01		2.4	
12.				964 25 .. AS11		2.4	
13.				964 25 .. AS21		2.3	
14.				without inspection measurement	Between impulse piping - pitch 54 mm	964 45 ..	
15.		964 45 .. AS1				2.5	
16.		964 45 .. AS2				2.5	
17.		with inspection measurement	Between impulse piping - pitch 54 mm			964 45 .. AS01	
18.	964 45 .. AS11						2,6
19.	964 45 .. AS21						2,6

\*) only as a special requirement after an agreement with the manufacturer

**Figure 1 - Two-way valve set (964 21..), dimensional drawing, scheme**

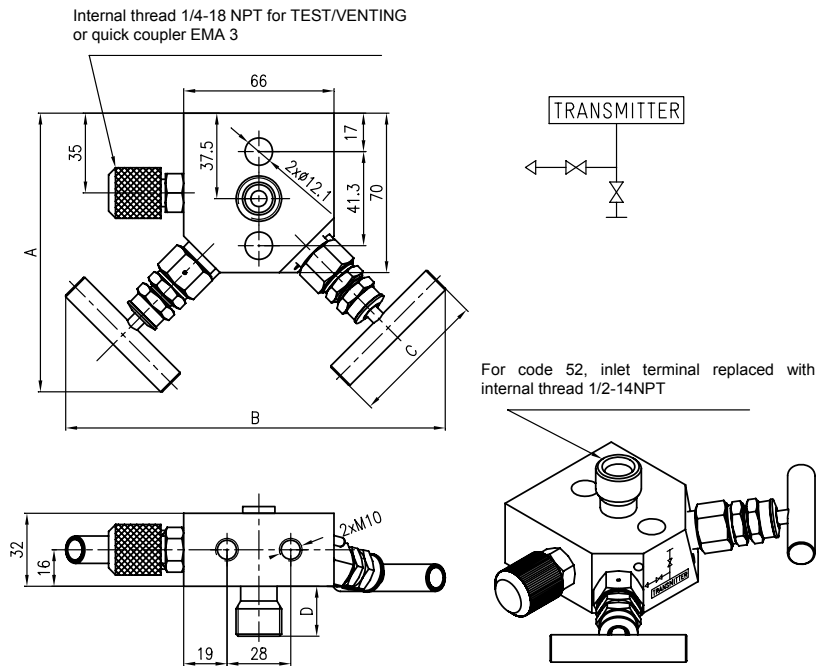

Spindle sealing material	A	B	C
FPM, NBR, EPDM	120	160	45
CHARTITE, PTFE, PEEK	130	170	60

Size of dimension "D" is specified at the applicable codes of connecting terminals in the manual of accessories, type 981.

**Figure 2 - Two-way valve set (964 22..) only as a special requirement, dimensional drawing, scheme**

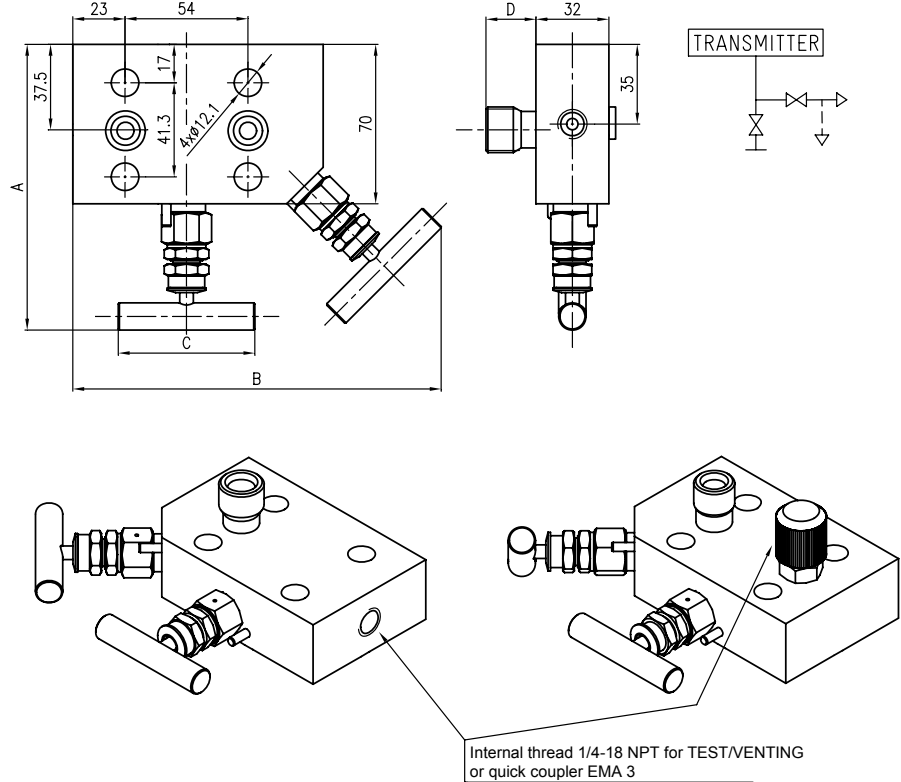

position TEST/VENTING shall be specified in the purchase order

Spindle sealing material	A	B	C
FPM, NBR, EPDM	120	160	45
CHARTITE, PTFE, PEEK	130	170	60

Size of dimension "D" is specified at the applicable codes of connecting terminals in the manual of accessories, type 981.

**Figure 3 - Two-way valve set (964 41..), dimensional drawing, scheme**

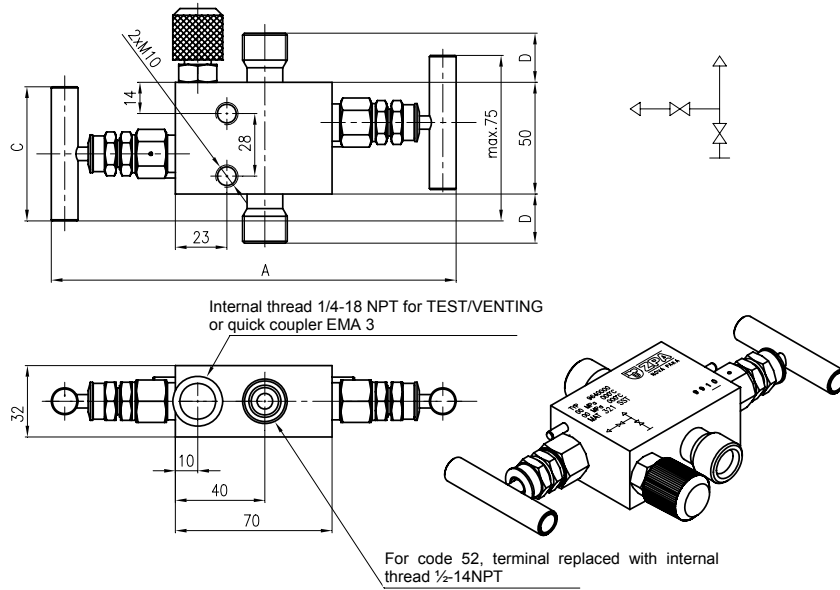

Spindle sealing material	A	C
FPM, NBR, EPDM	165	45
CHARTITE, PTFE, PEEK	185	60

Size of dimension "D" is specified at the applicable codes of connecting terminals in the manual of accessories, type 981.

**Figure 4 - Three-way valve set (964 23.. , 964 33..), dimensional drawing, scheme**

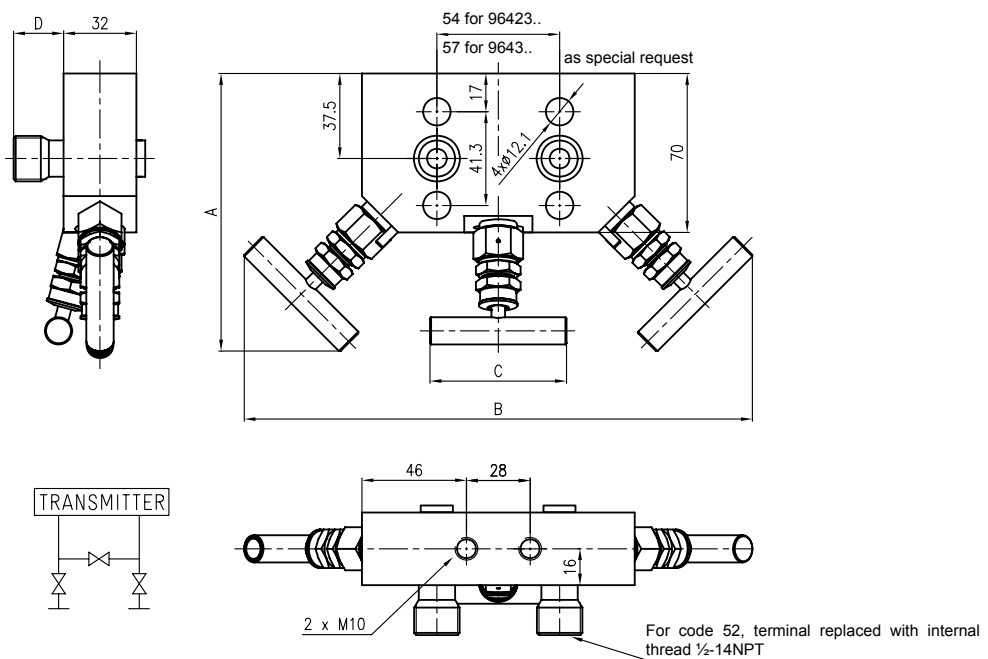

Spindle sealing material	A	B	C
FPM, NBR, EPDM	120	215	45
CHARTITE, PTFE, PEEK	130	235	60

Size of dimension "D" is specified at the applicable codes of connecting terminals in the manual of accessories, type 981.

Figure 5 - Three-way valve set (964 43..), dimensional drawing, scheme

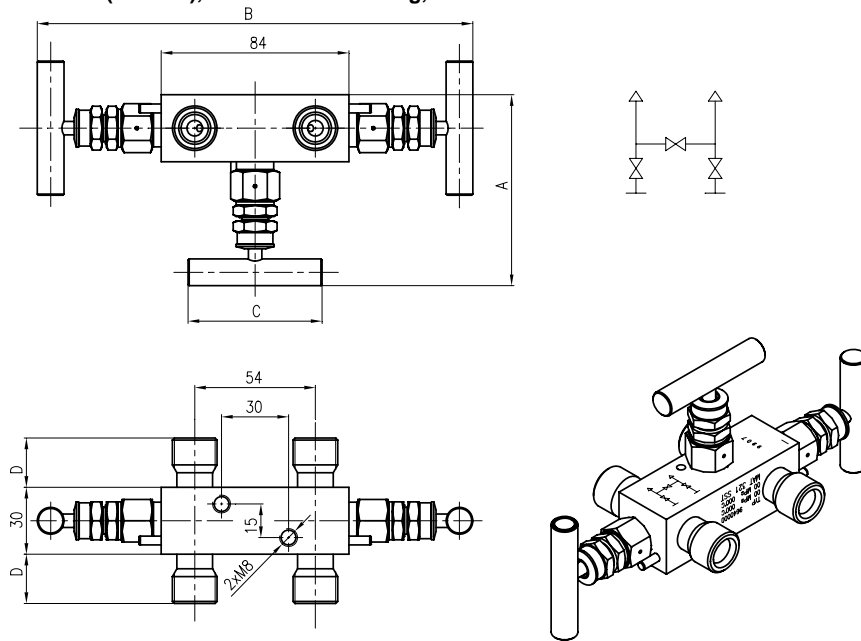

Spindle sealing material	A	B	C
FPM, NBR, EPDM	80	180	45
CHARTITE, PTFE, PEEK	90	200	60

Size of dimension "D" is specified at the applicable codes of connecting terminals in the manual of accessories, type 981.

Figure 6 - Three-way valve set with venting valves (964 24.. , 964 34..), dimensional drawing, scheme

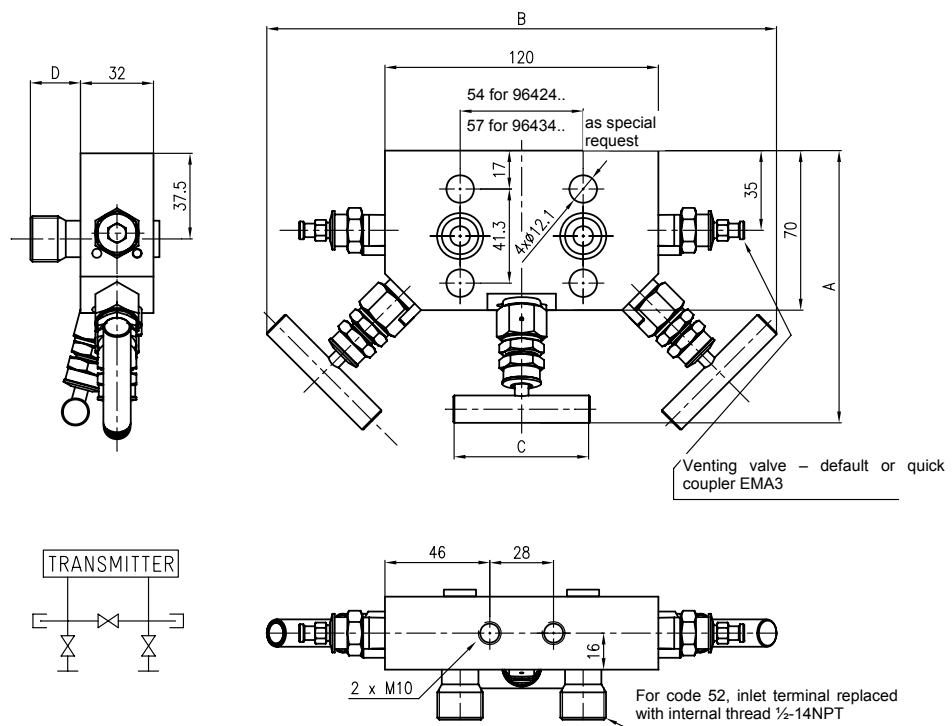

Spindle sealing material	A	B	C
FPM, NBR, EPDM	120	215	45
CHARTITE, PTFE, PEEK	130	235	60

Size of dimension "D" is specified at the applicable codes of connecting terminals in the manual of accessories, type 981.



Figure 7 - Three-way valve set with venting valves (964 44..), dimensional drawing, scheme

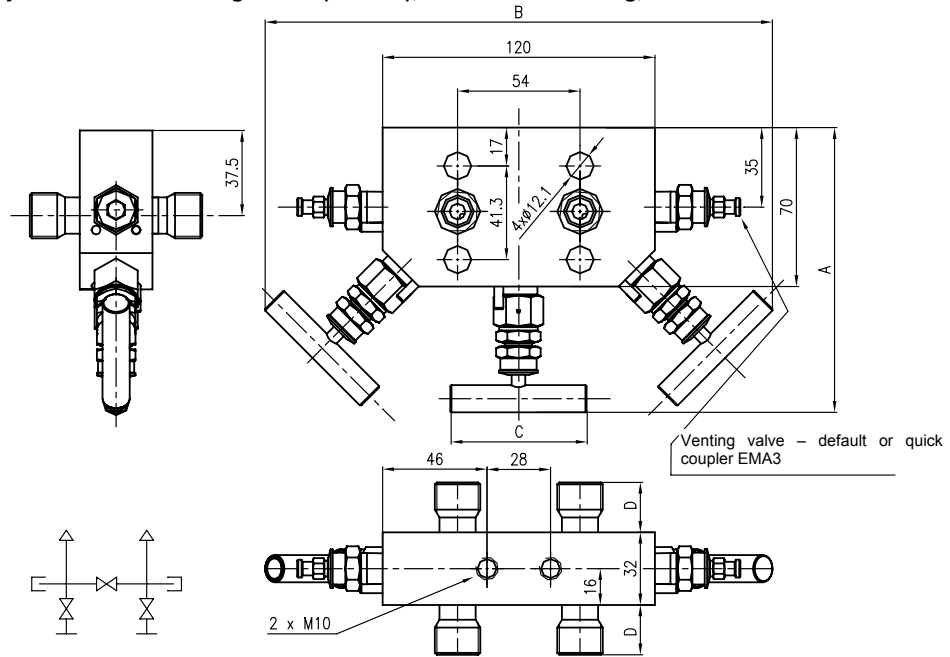

Spindle sealing material	A	B	C
FPM, NBR, EPDM	120	215	45
CHARTITE, PTFE, PEEK	130	235	60

Size of dimension "D" is specified at the applicable codes of connecting terminals in the manual of accessories, type 981.

Figure 8 - Five-way valve set (964 25.. , 964 35..), dimensional drawing, scheme

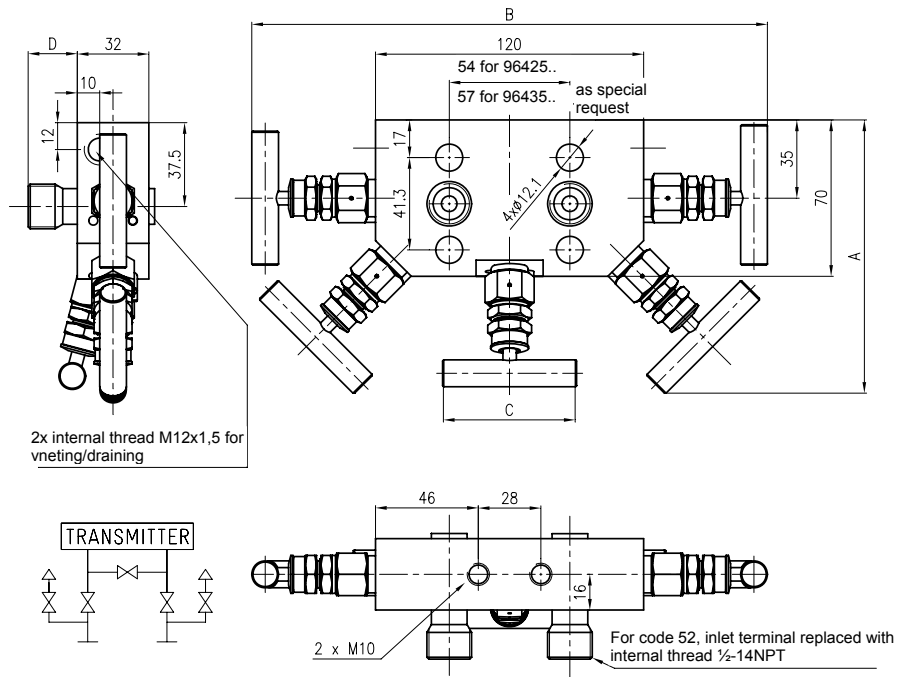

Spindle sealing material	A	B	C
FPM, NBR, EPDM	120	215	45
CHARTITE, PTFE, PEEK	130	235	60

Size of dimension "D" is specified at the applicable codes of connecting terminals in the manual of accessories, type 981.

Figure 9 - Five-way valve set (964 25.. AS1), dimensional drawing, scheme

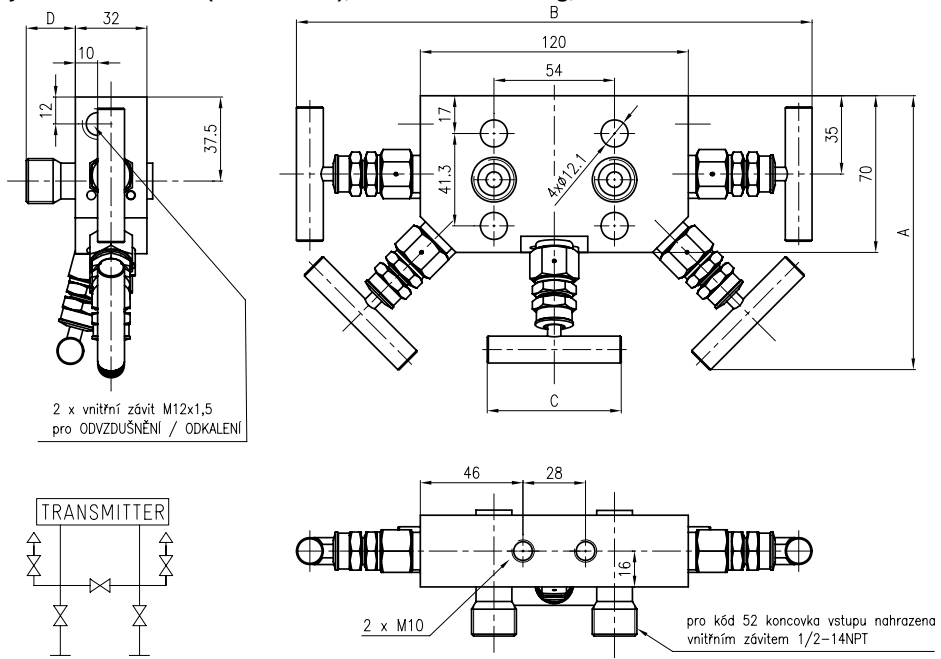

2x internal thread M12x1.5 for VENTING / DRAINING

For code 52, inlet terminal replaced with internal thread 1/2-14NPT

Spindle sealing material	A	B	C
FPM, NBR, EPDM	120	215	45
CHARTITE, PTFE, PEEK	130	235	60

Size of dimension "D" is specified at the applicable codes of connecting terminals in the manual of accessories, type 981.

Figure 10 - Five-way valve set (964 25.. AS2), dimensional drawing, scheme

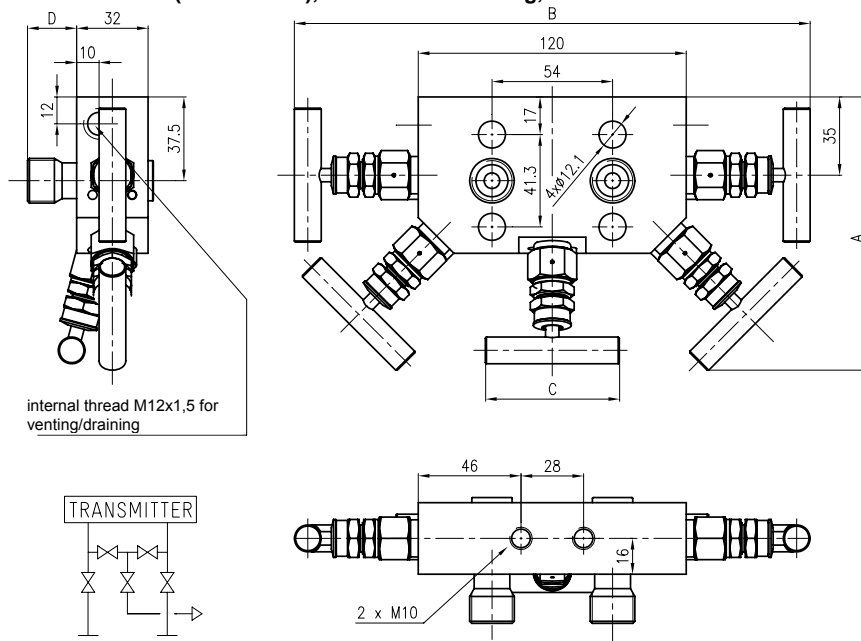

Spindle sealing material	A	B	C
FPM, NBR, EPDM	120	215	45
CHARTITE, PTFE, PEEK	130	235	60

Size of dimension "D" is specified at the applicable codes of connecting terminals in the manual of accessories, type 981.

Figure 11 - Five-way valve set (964 25.. AS01), dimensional drawing, scheme

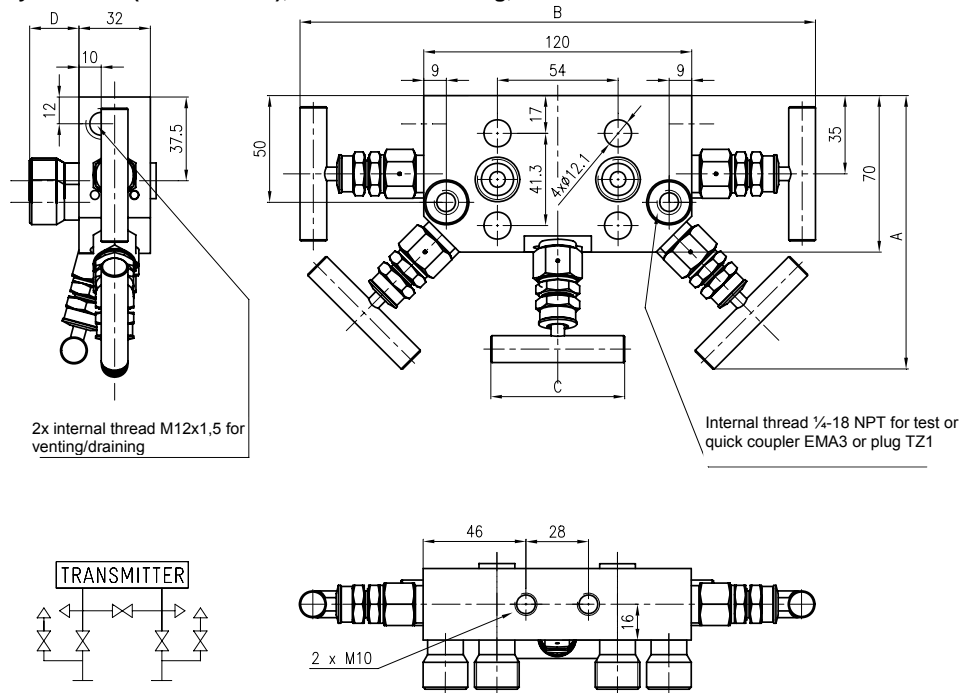

Spindle sealing material	A	B	C
FPM, NBR, EPDM	120	215	45
CHARTITE, PTFE, PEEK	130	235	60

Size of dimension "D" is specified at the applicable codes of connecting terminals in the manual of accessories, type 981.

Figure 12 - Five-way valve set (964 25.. AS11), dimensional drawing, scheme

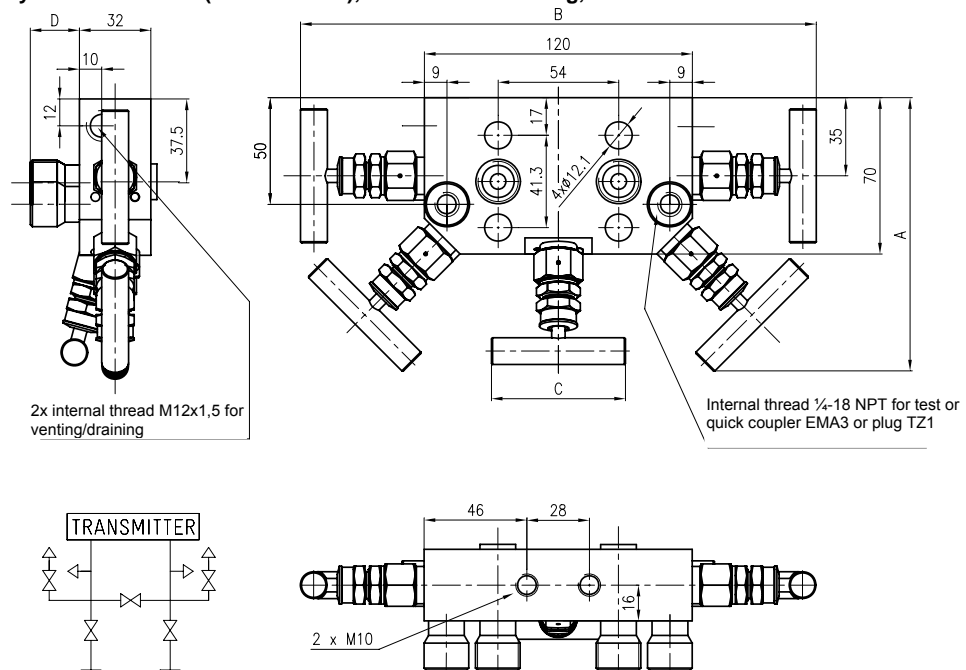

Spindle sealing material	A	B	C
FPM, NBR, EPDM	120	215	45
CHARTITE, PTFE, PEEK	130	235	60

Size of dimension "D" is specified at the applicable codes of connecting terminals in the manual of accessories, type 981.

Figure 13 - Five-way valve set (964 25.. AS21), dimensional drawing, scheme

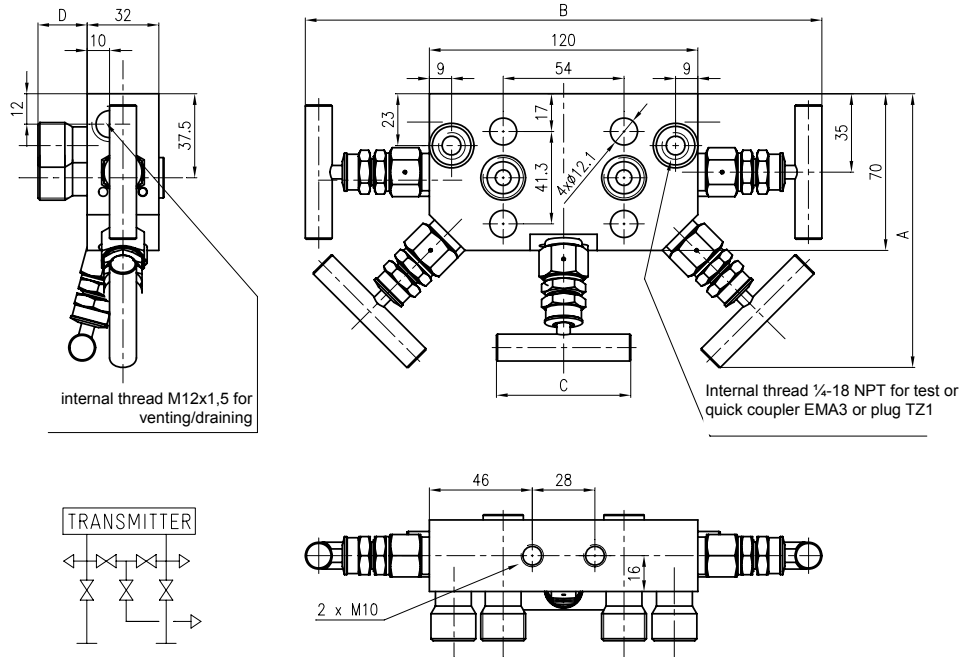

Spindle sealing material	A	B	C
FPM, NBR, EPDM	120	215	45
CHARTITE, PTFE, PEEK	130	235	60

Size of dimension "D" is specified at the applicable codes of connecting terminals in the manual of accessories, type 981.

Figure 14 - Five-way valve set (964 45..), dimensional drawing, scheme

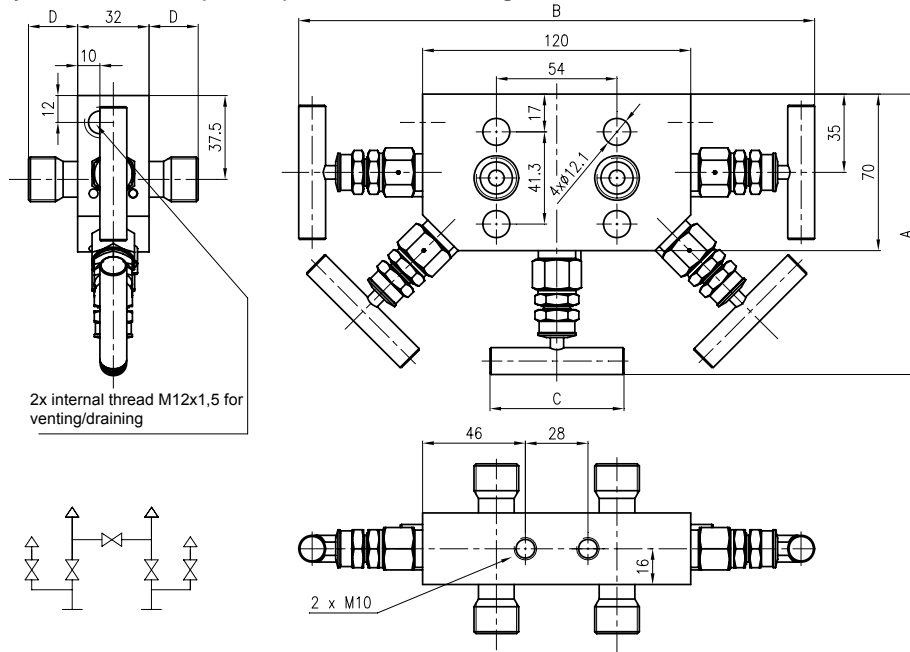

Spindle sealing material	A	B	C
FPM, NBR, EPDM	120	215	45
CHARTITE, PTFE, PEEK	130	235	60

Size of dimension "D" is specified at the applicable codes of connecting terminals in the manual of accessories, type 981.

Figure 15 - Five-way valve set (964 45.. AS1), dimensional drawing, scheme

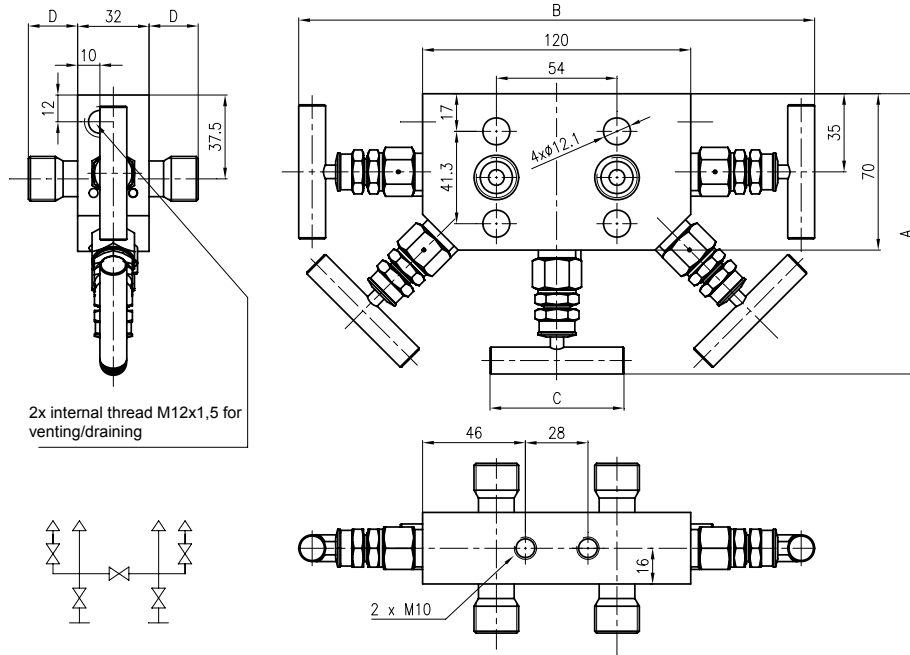

Spindle sealing material	A	B	C
FPM, NBR, EPDM	120	215	45
CHARTITE, PTFE, PEEK	130	235	60

Size of dimension "D" is specified at the applicable codes of connecting terminals in the manual of accessories, type 981.

Figure 16 - Five-way valve set (964 45.. AS2), dimensional drawing, scheme

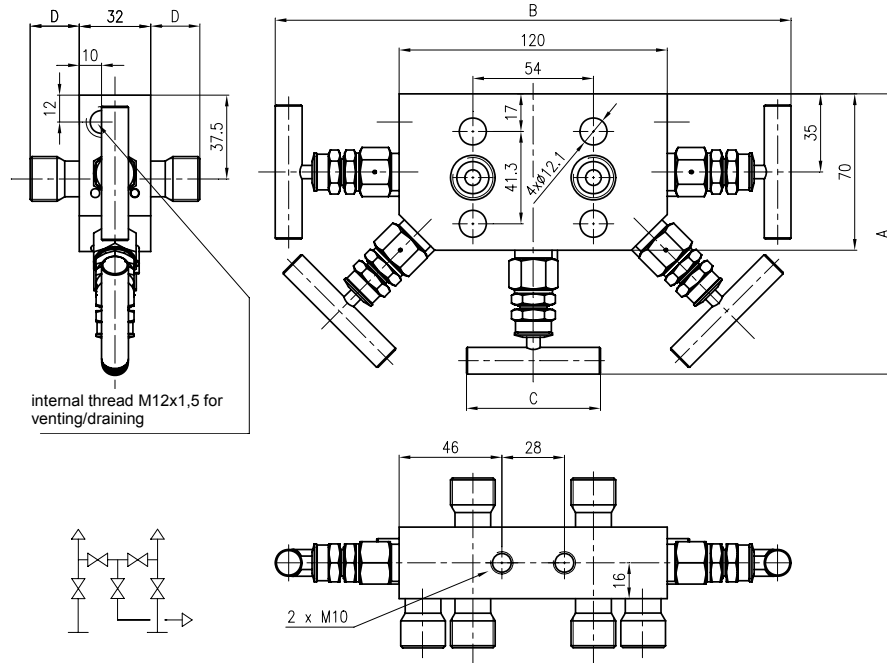

Spindle sealing material	A	B	C
FPM, NBR, EPDM	120	215	45
CHARTITE, PTFE, PEEK	130	235	60

Size of dimension "D" is specified at the applicable codes of connecting terminals in the manual of accessories, type 981.

Figure 17 - Five-way valve set (964 45.. AS01), dimensional drawing, scheme

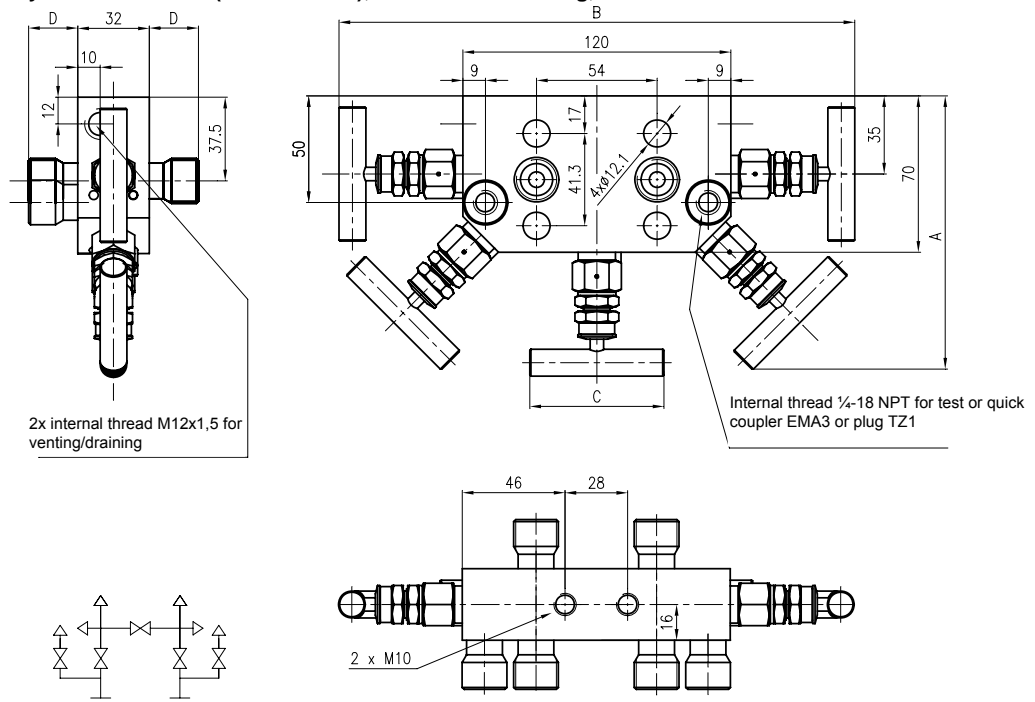

Spindle sealing material	A	B	C
FPM, NBR, EPDM	120	215	45
CHARTITE, PTFE, PEEK	130	235	60

Size of dimension "D" is specified at the applicable codes of connecting terminals in the manual of accessories, type 981.

Figure 18 - Five-way valve set (964 45.. AS11), dimensional drawing, scheme

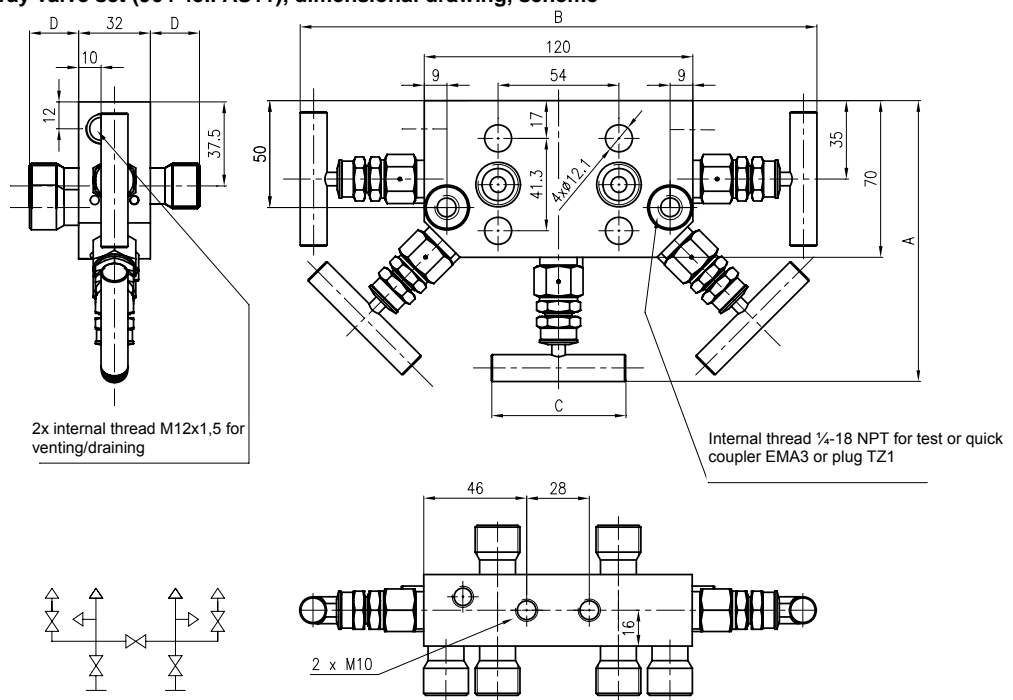

Spindle sealing material	A	B	C
FPM, NBR, EPDM	120	215	45
CHARTITE, PTFE, PEEK	130	235	60

Size of dimension "D" is specified at the applicable codes of connecting terminals in the manual of accessories, type 981.

Figure 19 - Five-way valve set (964 45.. AS21), dimensional drawing, scheme

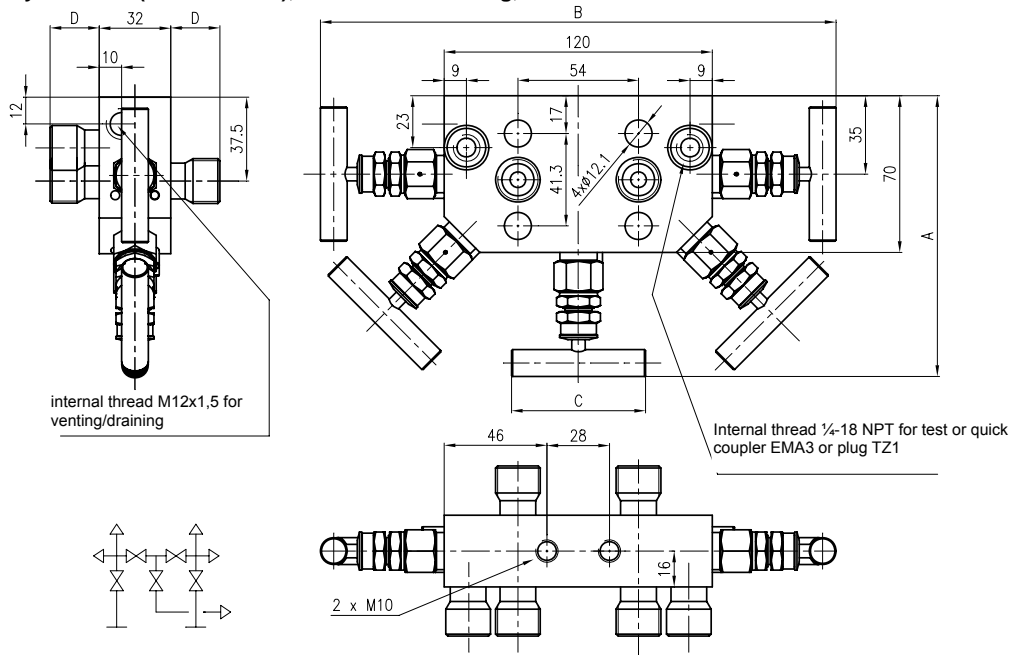

Spindle sealing material	A	B	C
FPM, NBR, EPDM	120	215	45
CHARTITE, PTFE, PEEK	130	235	60

Size of dimension "D" is specified at the applicable codes of connecting terminals in the manual of accessories, type 981.

## INSTALLATION AND CONNECTION

The valve installation may be realized by a worker of the installation or service organization.

The installation and commissioning for design for O<sub>2</sub> may only be performed by the organization, which has the authorization for installation and repair of gas equipment, issued by the organization of state professional supervision ITI Praha. Installation and uninstallation of screw-joint of type line 981 for selected equipment pursuant to the Decree 214/1997 Coll. for the connection of the valve set, type 964 ZPA Nová Paka, a.s., their operation and maintenance may only be performed by a bearer of the AUTHORIZATION, which is issued by the manufacturer of the armatures on the basis of taken training.

### INSTALLATION OF CONVENTIONAL SET ON PRESSURE DIFFERENCE SENSOR

The set of the design for conventional installation on the pressure difference sensor is attached to the sensor flange with the use of four screws. These screws shall be ordered as accessories because they have various lengths depending on the type of installation of the pressure difference sensor: with conventional or coplanar flange with the pitch of input holes 54 mm or 57 mm.

The sealing elements between the set and the sensor consist of two sealing rings PTFE, 24 x 18 x 3, which are included in the delivery of the set. The shape of the groove complies with standard ČSN EN 61518 – type A and also enables to use the sealing O-ring 20x2.65.

Installation process:

Sealing rings from the accessories of the set shall be pressed into the grooves at the outlet of the valve set.

Attach the valve set to the flange of the pressure difference sensor with four screws of carbon (stainless) steel. With the use of a wrench, tighten the screws crosswise with initial torque of 34 Nm (17 Nm) so that the gap between the flange and the valve unit is the same along the whole periphery.

Then tighten the screws in the same order crosswise with the use of the final torque of 73 Nm (34 Nm). The torque in brackets applies to stainless screws, which shall be greased before the installation. Carbon steel screws do not require any lubrication.

### INSTALLATION OF SET BETWEEN IMPULSE PIPING

Connect the armature to the impulse piping by means of either internal threads or weld-on terminals.

All types of connection are specified in the manual for accessories, type 981, together with dimensional drawings and the described type of installation.

### PIPING CLEANNESS

Before the armature is connected, the piping shall be perfectly cleaned. To prevent any deposit of impurities in the valve set, cleanness of medium in the piping shall be ensured in a suitable way (drain tanks, etc.).

### OPERATION POSITION

The operation position of the armature is discretionary. If possible, use a suitable holder from the manual for accessories, type 981.

## COMMISSIONING

After the installation of the armature and venting the piping, the equipment is prepared for operation.

To vent, you should use either condensate (cold, if possible) or fill the whole system, including the sensor, with clean service water. In this case, the static pressure in the piping shall be zero. Equalizing the levels in both condensation tanks is made by turning the whole set of the orifice; at the same time, it is recommended to check the levels with a hose level. Equalizing the levels is facilitated if a double condensation tank is used.

Filling the system with condensate shall be realized when the thermal circuit is cut off:

a) Check if all valves, including the set, are closed. Open the equalizing valve (EQUALIZE).

b) Open both drain valves (VENT). By partial opening of closing valves of the orifice measurement, the impulse piping is filled with condensate. Let water flow till all air is pressed out of the impulse piping and only water is coming out from the drain holes. Then close the drain valves (VENT). While doing it, the whole condensate may never be used up; steam may not enter the five-way set.

c) Wait till the concentrate is filled. Open the closing valves (BLOCK) (one is sufficient) of the set and release the input screw joint on the set with the use of a wrench so that the chambers of the pressure difference sensor and the set are filled with water and, at the same time, air could escape. If venting is realized with the use of hot condensate, it is recommended to wait till condensate in the connecting piping is cooled down (approx. 15 to 60 minutes, depending on the length of piping and temperature of condensate). As soon as all air is pressed out of the sensor, the screw joint shall be tightened again.

In case of three-way valve set with venting valves, these valves can be used for venting. Venting shall be realized in the shortest possible time to avoid excessive warming of the sensor. By knocking on the impulse piping, air blisters are released, which could stick on the piping wall when it is flooded.

**RESETTING THE PRESSURE DIFFERENCE SENSOR**

Close the equalizing valve (EQUALIZE) of the set. Both closing valves (BLOCK) are open. Wait till condensate is filled in the condensation tanks.

By switching on the mains switch, the electronic part of the set is put into operation (pressure sensor, pressure difference sensor, mathematic element).

Connect milliammeter into the output from the pressure difference sensor serially with the mathematic element. After switching on the mains switch, the whole device shall be let at least 30 minutes till the temperature is stabilized. If venting has been realized with hot condensate, which entered the sensor, this time shall be prolonged till temperature of water in the impulse piping and in the pressure difference sensor is equalized with the ambient temperature. When the steam flow is zero (steam flow shall be cut off so that the level of condensate in the condensation tanks is not changed) and there is full operation static pressure, press the zero reset button (for sensors with SMART electronics) or use the relevant adjusting element for resetting zero to adjust the output current of the pressure difference sensor to -0.01 mA (3.99 mA). It will equalize the deviation of zero caused by a possible difference of level heights in both condensation tanks and the impact of the static pressure on the pressure difference sensor. Thereby the whole set is prepared for operation.

If required, an appointed worker of the installation and service organization may provide the valve set with seals with the mark of the installation and service organization.

**OPERATION AND MAINTENANCE**

**CONTROL MOMENT OF SPINDLE**

The following table provides informative values of control moments of spindle and moments required to close the valve for various types of sealing subjected to different medium pressures. The values are only for information purposes because real values may differ depending on the tightening of the seal cover.

Medium pressure (MPa)	Control moment (Nm)	Closing moment (Nm)
0	0.1 to 1.0	2.5 to 4.0
40	2.0 to 3.0	4.0 to 6.0

**WARNING:**  
 **To avoid any damage to the seat sealing of the valve unit with soft sealing (code S3), smaller closing moment (max. 4 Nm) shall be used when closing the valve.**

**VENTING AND DRAINING**

During the operation, air can leak from the main piping to the impulse piping. Therefore, it is necessary to vent the impulse piping by means of drain valves of the five-way set or the venting valves of the valve set with venting. The interval of venting and draining shall be chosen according to the local conditions.

Venting process shall be realized at zero flow. First open the equalizing valve (EQUALIZE). Close the closing valves (BLOCK). Slowly open the drain valves (VENT). As soon as water occurs at the outlet from the drain holes, close the drain valves (VENT). Open the closing valves (BLOCK). Finally close the equalizing valve (EQUALIZE).

During this venting, impurities from the impulse piping are removed, too.

If it is not possible to realize the venting at zero flow and if opening the equalizing valve can result in a loss of condensate, venting may be performed with closed equalizing valve (EQUALIZE). However, in that case the pressure difference sensor is subjected to overload with full static pressure.

Therewith the venting is completed. Fully open closing valves of measurement.

**WARNING:**  
**Steam may not enter the pressure difference sensor and the valve set!**

**RESETTING PRESSURE DIFFERENCE SENSOR**

If the levels of condensate in the condensation tanks were equalized correctly during commissioning, it is possible to inspect and adjust the zero of the pressure difference sensor during period inspections; in that process, the equalizing valve (EQUALIZE) and one closing valve (BLOCK) shall be open.

**ELIMINATION OF LEAKAGE OF SPINDLE SEAL**

In case of an armature with valve unit with seal from expanded graphite, PTFE or PEEK, possible leakage around the spindle can be eliminated by tightening the seal cover after previous releasing of the nut. After the seal has been tightened, the nut shall be tightened, too.

**ARMATURE CLEANING**

This activity may only be performed by service workers of the valve manufacturer.

**PROCEDURE WHEN FINDING LEAKAGE OF CONNECTION WITH THREADED RINGS**

Possible leakage of the connection can be caused by unprofessional installation, e.g. by failure to comply with specified torque (i.e. insufficient or excessive tightening of the cap nut), with minimum straight part of the tube from its end or by using this connection in the conditions with increased level of vibrations without any fixation of armature and connecting tubes, in particular longer ones.

**WARNING**  
 **The cap nut may never be tightened (released) under pressure – it could cause lethal injury!!!**

Uninstallation and repeated installation of the connection shall be realized pursuant to manual for accessories, type 981 – Connecting terminals.

**SPARE PARTS**

The armature design does not require any delivery of spare parts.

**WARRANTY**

Pursuant to § 429 of the Commercial Code and the provisions of § 620 (2) of the Civil Code, the manufacturer warrants for technical and operation parameters of the product specified in the manual. The warranty period is 36 months from the receiving of the product by the customer, unless established otherwise in the contract. The manufacturer warrants for the parts, which are subjected to natural wear and are replaceable as a part of common maintenance of the product (plug sealing, sealing O-rings, etc.), for the period of 24 months.

Rejection of defects shall be enforced in writing at the manufacturer within the warranty period. The rejecting side shall identify the product name, ordering and manufacturing numbers, date of issue and number of the delivery note, clear description of the occurring defect and the subject of the claim. If the rejecting side is invited to send the device for repair, it shall do so in the original package of the manufacturer and/or in another package ensuring safe transport.

The warranty shall not apply to defects caused by unauthorized intervention into the device, its forced mechanical damage or failure to comply with operation conditions of the product and the product manual.

**REPAIRS**

The valve sets shall be repaired by the manufacturer. They shall be sent for repair in the original or equal package without accessories.

**DISABLING AND LIQUIDATION**

They shall be realized in compliance with the Waste Act No. 106/2005 Coll.



The product and its package do not include any parts that could impact the environment. Products that are withdrawn from operation, including their packages, may be disposed of to sorted or unsorted waste pursuant to the type of waste.

The package of the product can be recycled completely. Metal parts of the product are recycled, non-recyclable plastic materials shall be disposed of in compliance with the aforesaid Act.

**NOVÁ PAKA**

ZPA Nová Paka, a. s.  
Pražská 470  
509 39 Nová Paka

tel.: spojovatel: 493 761 111  
fax: 493 721 194  
e-mail: obchod@zpanp.cz

www.zpanp.cz  
bankovní spojení: ČSOB Trutnov  
číslo účtu: 271 992 523/0300

IČO: 46 50 48 26  
DIČ: CZ46504826

August 2006

© ZPA Nová Paka, a.s.

**1015**