



Thermoelectric temperature sensor with metal protective tube without converter, with converter or Ex ia design type series 350 type 351

PRODUCT MANUAL

FOR DESIGNS WITH CONVERTER A MANUAL IS ENCLOSED TO THE RELEVANT CONVERTER
FOR DESIGNS WITH CONVERTER AND DISPLAY A MANUAL IS ENCLOSED TO THE RELEVANT CONVERTER AND DISPLAY

APPLICATION

- For remote measurement of temperature of gases, for which the properties of the material of the protective tube are suitable (e.g. in furnaces)
- For explosive environment in areas Zone 2, Zone 1 and Zone 0 pursuant to EN 60079-10 -1 in case of application of the converter Ex ia or in case of connection to Ex ia circuit pursuant to EN 60079-25
- As a complete set with control or diagnostic systems for process monitoring
- Design with converter to convert the signal of the thermoelectric sensor to unified output signal 4 to 20 mA or digital signal (converter with HART protocol)
- Design with display to instantly display the value of the measured quantities
- For the environment, where mechanical resistance is required pursuant to EN 60068-2-6 (class AH2) and seismic capability of the electrical equipment of the safety system of the nuclear power stations pursuant to IEC 980 (MVZ level SL-2).

The sensors with converter and in Ex ia design are rated products pursuant to the Directive 2014/34/EU of the European Parliament and the Council and EU Declaration of Conformity EU - **251000** is issued for them.

DESCRIPTION

The sensor consists of a replaceable measuring insert with a flange and a ceramic terminal board or installed two-wire converter (insulated or un-insulated, also in design Ex i) and protective armature consisting of a head and a protective tube. The head is provided with a lid and cable outlet for connecting wiring. The terminal board of the sensor (of the converter) is accessible after tilting away the lid of the head, which is connected with one screw. On the head, the sensor is provided with an external terminal for connection of the grounding wire or wire for mutual interconnection.

The sensor with converter in design Ex ia is provided on its head with both external and internal terminals for the connection of the grounding wire or wire for mutual interconnection. The converter is installed either directly on the flange of the measuring insert or in the lid of the head.

The sensor with converter is supplied from an external source. The installed converter is set-up to the required range at the sensor manufacturer.

To measure temperature, a defined change of thermoelectric voltage of the sensor in dependence on the change of temperature of the measured environment is used.

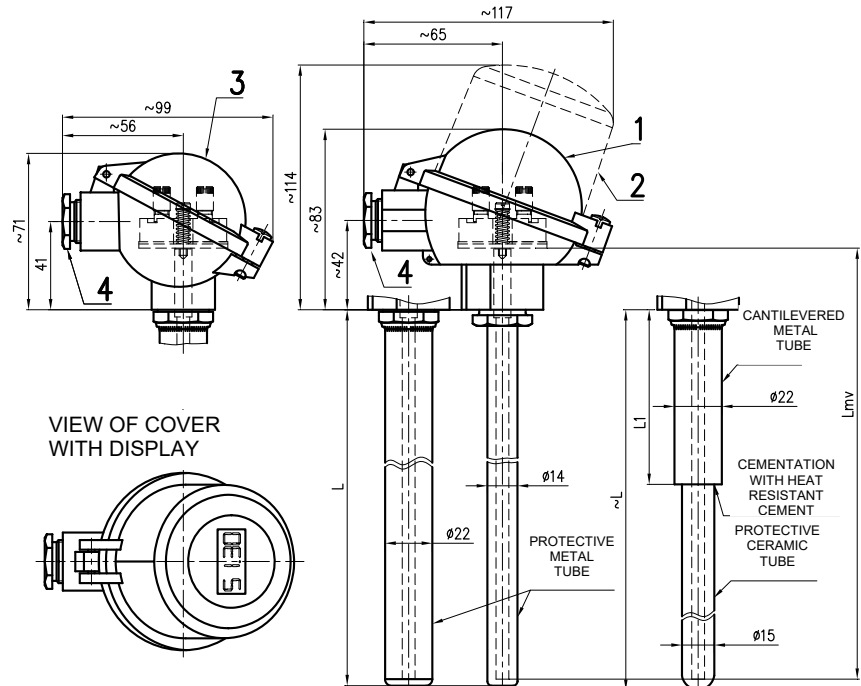

- 1 - Ball head (Al alloy)
(for converter Ex i with both external and internal terminals)
or plastic ball head
(It cannot be used for converter Ex i)
 - 2 - Ball head with increased lid (Al alloy)
without display for converter in the lid or with display
(for converter Ex i with both external and internal terminals)
 - 3 - Small ball head (Al alloy)
(only for terminal board or converter INPAL 420)
 - 4 - Cable outlet M20x1.5
- L Nominal length
L_{mv} Length of measuring insert

TECHNICAL DATA

The sensor dimensions are based on DIN 43772 and original ČSN 25 8301. The sensor is designed pursuant to EN 61140 as an electrical equipment of protection class III for the application in networks with category of overvoltage in installation II and pollution grade 2 pursuant to EN 61010-1; the follow-up (evaluation) device shall comply with Article 6.3 of the said standard.

Measuring range:

for thermocouple type "J" -200 to 800 °C
for thermocouple type "K" -200 to 1150 °C

For other type of thermocouple is limited by upper limit of measuring range by the resistance of this thermocouple.

The upper limit of the measuring range is limited by resistance of the material of the applied protective tube (see table 1 - Design of temperature sensors and table Application of protective tube material in Article OPERATION CONDITIONS. Measuring range of the sensor with converter is given by the range of the selected converter.

Electric strength pursuant to EN 61010-1 Article 6.8.3:

500 V eff (only measuring insert without converter or design with insulated converter)

Electric insulation resistance pursuant to EN 61515:

min. 1000 MΩ, at ambient temperature 20±15°C and max. 80% relative humidity

Intrinsically safe pursuant to EN IEC 60079-0 and EN 60079-11:

⊕ II 1 G Ex ia IIC T5/T6 Ga
(Meaning of designation - see figure 6)
P_i = 500 mW T6 (-60°C ≤ Ta ≤ 68°C)

Intrinsically safe circuit parameters:

only for thermocouple "K" and "J", with measuring insert Ø6

U_i = 60 V U_o = 100 mV
I_i = 100 mA I_o = 50 mA
P_i = 500 mW P_o = 25mW
C_i = 850 pF/m
L_i = 16 µH/m



WARNING

The device must be installed in a housing that meets the degree of protection against intrusion of at least IP 20. The casing of the measuring insert is not separated from the inner intrinsically safe circuit according to the standard EN 60079-11. This information must be taken into account during installation.



Intrinsically safe version with converter:

according to built-in converter

Power supply of the converter:

DC 24 V from source SELV, e.g. INAP 16 and INAP 901

Other data of the converter: refer to enclosed manual

Display: LED display to loop 4-20mA
other data refer to enclosed manual

Ingress protection pursuant to ČSN EN 60529:

sensor with metal protective tube IP65
sensor with ceramic protective tube IP65/IP60
(IP65 - head of sensor, IP60 – protective tube)

Sensor weight:

With ball head (Al alloy)

Nominal length L	350 mm	approx. 0.96 kg
	500 mm	approx. 1.10 kg
	710 mm	approx. 1.28 kg
	800 mm	approx. 1.36 kg
	1000 mm	approx. 1.54 kg
	1400 mm	approx. 1.89 kg
	1600 mm	approx. 2.07 kg
	2000 mm	approx. 2.42 kg

Operation position:

discretionary; the outlet shall not be situated upwards

Type of operation:

continuous

Applied materials:

Protective tube	steel	1.4541
		1.4749
		1.4845 or 1.4841
gas-tight ceramics	LUNIT 73 (content approx. 60 % Al ₂ O ₃) corresponds to a subgroup C 610 pursuant to EN 60672-3)	
	LUXAL 203 (content min. 99,5 % Al ₂ O ₃) corresponds to a subgroup C 799 pursuant to EN 60672-3)	
Measuring insert tube for thermocouple	J	steel 1.4541
	K	INCONEL 600
Cantilevered metal tube for ceramic tube		steel 1.4541
Head		aluminium alloy painted with polyester paint
		plastic PPO (phenyl polyoxide)
Sealing of cover of head and outlets		oil-resistant rubber
Head terminals of terminal board		brass with Ni surface
Connecting items of sensor		stainless steel

OPERATION CONDITIONS

The environment is defined by the group of parameters and their severity grades IE 36 pursuant to EN 60721-3-3 and the following operation conditions.

Ambient temperature for sensor head and outlet:

- for design without converter -50 °C to 120 °C
- for design with converter pursuant to type of the converter (refer to enclosed converter manual)

- for design with converter and display according to type of the converter and display (refer to enclosed converter and display manual)

Intrinsically safe measuring inserts can be used in intrinsically safe circuits of group II electrical equipment.

Relative ambient humidity:

- for design without converter 10 to 100 % with condensation, with upper limit of water content 29 g H₂O/kg of dry air
- for design with converter pursuant to type of the converter (refer to enclosed converter manual)
- for design with converter and display according to type of the converter and display (refer to enclosed converter and display manual)

Atmospheric pressure: 70 to 106 kPa

Maximum speed of flow of gaseous medium: 2 m/s

Ambiances:

Nominal length L[mm]	350 to 1000	1400 to 2000
Frequency range [Hz]	10 to 55	
Drift amplitude [mm]	0.15	0.075
Acceleration amplitude [ms ⁻²]	19.6	9.8

Resistance of material of PPO (phenyl polyoxide) head:

Kerosene	partially resistant
Diesel oil	resistant
Benzene	partially resistant
Animal and vegetable oils	resistant
Weak hydrohides	
Strong hydroxides	
Weak acids	
Strong acids	
Sea water	
Trichloroethylene	

Resistance of material of lid sealing (oil-sealing rubber):

Alcohol	resistant	
Ether		
Benzol		
Petrol		
Ester		
Animal and vegetable oils		
Mineral oil		
Engine oil		
Weak alkali hydrohides		
Strong alkali hydroxides		non-resistant
Weak acids		resistant
Strong acids		non-resistant
Sea water		resistant
Trichloroethylene		partially resistant
Hot water		

Application of protective tube material:

Material	Resistance in the atmosphere			
	sulfuring		nitrogening, poor on oxygen	carbonizing
	oxidative	reductive		
1.4845	good	low	good	satisfactory
1.4841				
1.4749	very good	good	low	low
1.4541	good	low	good	satisfactory
LUNIT 73 *)	very good (suitable for alkaline-free gases and hydrofluoric acid)			
LUXAL 203 *)	very good (contact with alkali vapors allowed to 1500 °C)			

Degree of resistance: 1 – very good 3 – satisfactory (middle)
2 – good 4 - low (unsatisfactory)

The highest temperature of use may be less than 200 ° C in atmospheres than hot air, as shown in Table 1

*) material suitable for abrasive media, highly chemically resistant and refractory, very fragile, resistance against sudden change of temperature min. 150 K, bending strength for LUXAL 203 is min. 300 MPa, for LUNIT 73 min. 120 MPa

METROLOGICAL DATA

Sensing probe: measuring thermocouple J (Fe-CuNi) or K (NiCr-NiAl) pursuant to EN 60584-1, Ø 6 mm, tolerance class 2 or 1, single with insulated measuring connection or double with independent measuring connection

Output signal

of analogue converter (linear with thermoelectric voltage):
4 to 20 mA

of programmable converter (linear with measured temperature):
4 to 20 mA (+ digital for HART protocol)

Calibration depth of immersion of the measuring insert of the sensor

for temperature points within the range from -70 to 250°C:
200 mm (min. 160 mm)

for temperature points over 250°C:
300 mm (min. 260 mm)

The distance of the flange of the measuring insert from the medium level in the calibration bath shall be at least 40 mm at temperatures up to 250°C and min. 70 mm at temperatures over 250°C.

Temperature response time pursuant to EN 60751 in whirling water

for tube \varnothing 14 mm (characteristic value): $\tau_{0.5}$ 75 s

$\tau_{0.9}$ 90 s

for tube \varnothing 22 mm (characteristic value): $\tau_{0.5}$ 90 s

$\tau_{0.9}$ 370 s

DESIGNATION:**Data on head label**

- Trademark of the manufacturer
- Made in Czech Republic
- Type of the thermoelectric sensor / tolerance class
- Measuring range or adjustable range of the converter
- Product ordering number
- Ingress protection
- Time code (Serial number for calibrated design, design with tolerance class A, design with converter, Ex ia design)
- Output signal 4 to 20 mA (design with converter)
- Ambient temperature
- Mark of non-explosiveness (Ex ia design):
 II 1 G Ex ia IIC T5/T6 Ga
 and number of the EU-Type Examination Certificate
- Mark CE 1026

Data on label of measuring insert

- Trademark
- Type of sensor
- Time code (Serial number for calibrated design, design with tolerance class A, design with converter, Ex ia design)

Data on converter label

- Trademark
- Type of sensor
- Set-up temperature range
- Designation of non-explosiveness and EU-Type Examination Certificate number (for design with converter Ex ia)
- CE mark with identification number of the notified person (for design with converter)

Data on display

- Trademark
- Designation of non-explosiveness and EU-Type Examination Certificate number (for design with converter Ex ia)
- CE mark with identification number of the notified person (for design with converter)

CERTIFICATION

- Non-explosiveness Ex ia, EU-Type Examination Certificate pursuant to the Directive 2014/34/EU FTZU 21 ATEX 0007X
- Non-explosiveness Ex i, EU-Type Examination Certificate pursuant to the 2014/34/EU (ATEX 114), (pursuant to the type of the converter and display)

RELIABILITY

Indicators of reliability in operation conditions and ambient conditions specified herein

- Medium time of operation between failures 96 000 hours (inf. value)

Expected service life 10 years

DELIVERY

Unless agreed otherwise with the customer, each delivery includes

- Delivery note
- Sensor pursuant to the purchase order
- Separately ordered accessories:
 - o Connecting flange or nipple with threaded ring, Instruction label is delivered with each nipple with a threaded ring
- Optional accessories to sensor with programmable converter
 - o Configuration (parameterization) programme pursuant to the required converter
 - o Communication modem (for serial port RS 232C) pursuant to the required converter
- Accompanying technical documentation in Czech
 - o Product quality and completeness certificate, which also serves as the warranty certificate
 - o EU Declaration of Conformity for Ex ia design
 - o Calibration sheet (for uncertified calibrated design)
 - o Product manual

If it is established in the purchase contract or agreed otherwise, the following documentation can be also delivered with the product

- EU Declaration of Conformity (for design with converter)
- Copy of the Inspection Certificate 3.1 acc to EN 10204 for material of protective tube and tube with the heat number
- Declaration of Conformity with purchase order 2.1 acc. to EN 10204
- Copy of EU-Type Examination Certificate pursuant to the 2014/34/EU (ATEX 114), for Ex ia design
- Test report about the seismic and the vibration qualification
- Declaration of Conformity of the supplier pursuant to EN ISO/IEC 17050-1

CALIBRATION

It is realized pursuant to TPM 3322-94 and in compliance with EN 60584-1 usually in three temperature points evenly distributed within the operation range of the sensor or in the points according to the requirement of the customer. Calibration sheets with measured data are issued for calibrated sensors.

PACKING

Both sensors and accessories are delivered in a packing ensuring resistance to the impact of thermal effects and mechanical effects pursuant to controlled packing regulations.

TRANSPORT

The sensors may be transported on conditions corresponding to the set of combinations of classes IE 21 pursuant to EN IEC 60721-3-2 (i.e. by airplanes and trucks, in premises that are ventilated and protected against atmospheric effects).

STORAGE

The sensors may be stored on conditions corresponding to the set of combinations of classes IE 21 pursuant to EN IEC 60721-3-2 (i.e. in airplanes and trucks, in ventilated areas and protected against weather).

ORDERING TEMPERATURE SENSORS

The purchase order shall specify

- Name
- Product ordering number
- Ex ia design is ordered using codes JIX, or DUX according to Table 1
- Additional requirements for sensor design according to Table 2
- Request for additional documentation according to the Table 2
- Measuring range
- If calibration is required and in what temperature points
- If as sparely ordered accessories by type 991 the connecting flange or nipple with threaded ring is required to supply
- If optional accessories to the sensor with programmable converter is required
- Requirement for other documentation pursuant to Article DELIVERY

- Other (special) requirements
 - Number of pieces
- Behind the required range of measured temperature (i.e. so-called lower and upper temperature limits in °C), the customer shall identify other non-standard required parameters for converter configuration (e.g. indication of sensor tripping, dampening, required designation - tagging etc.).

PURCHASE ORDER EXAMPLE

Standard design :

Thermoelectric temperature sensor with metal protective tube without converter
 351 401 131 K2/JI/Q42
 Calibration points 600, 800 a 1000°C
 Range -200 to 1100°C
 6 pcs

Special requirement:

Thermoelectric temperature sensor with metal protective tube with converter
 351 901 131 J2/HCF
 Nominal length L 380 mm
 Range 0 to 300°C
 6 pcs

ORDERING ACCESSORIES

The purchase order shall specify:

- Name
- Product ordering number
- Number of pieces

PURCHASE ORDER EXAMPLE

Standard design:

Connecting flange
 991 UP 14
 5 pcs

TABLE 1 - DESIGN OF TEMPERATURE SENSORS WITH PROTECTIVE TUBE, TYPE 351

SPECIFICATIONS					ORDERING NUMBER																		
					351	x	x	x	x	x	x	x	x	x	/xxxxxxx	/xxx							
Nominal length L [mm]	350	Length of measuring insert L _{mv} [mm]	375	Length L1 [mm]	200	1																	
	500		525		400	2																	
	710		735			3																	
	800		825			4																	
	1000		1025			5																	
	1400		1425			6																	
	1600		1625			7																	
	2000		2025			8																	
	Other (max. 3000, ceramic tube max. 1600) *)					9																	
Extension length	Without extension					0																	
Material of protective tube and maximum measuring range of sensor ***)	1.4845 or 1.4841		-200 to 1100°C																				
	1.4541 **)		-200 to 800°C																				
	1.4749 (only for Ø 22 mm)		-200 to 1100°C																				
	LUNIT 73		0 to 1300°C (short time 1500°C)																				
	LUXAL 203		0 to 1600°C (short time 1800°C)																				
Other *)																							
External ø of protective tube [mm]	14																						
	22																						
	22 cantilevered metal tube, 15 ceramic tube																						
Sensor head	Ball (Al alloy) (for converter Ex i with both external and internal terminals)																						
	Ball, plastic (it cannot be used for converter Ex i)																						
	Ball head with increased lid (Al alloy) without display for converter in the lid or with display (for converter Ex i with both external and internal terminals)																						
	Ball, small (Al alloy) (only for terminal board and converters APAQ-HCF, MINIPAQ-HLP)																						
	Other *)																						
Measuring insert tube for sensor with protective tube (Ø6 ± 0,1 mm)																							
Thermocouple	K																						
	J																						
	Other *)																						
Accuracy class	1 *)																						
	2																						
Design of measuring ends of thermocouple pursuant to figure 1	Single thermocouple, insulated end																				/JI		
	Double thermocouple, independent end																				/DU		
	Single thermocouple, insulated end																				/JIX		
	Double thermocouple, independent end																				/DUX		

TABLE 1 - DESIGN OF TEMPERATURE SENSORS WITH PROTECTIVE TUBE, TYPE 351 (continuation)

SPECIFICATIONS						ORDERING NUMBER														
						351	x	x	x	x	x	x	x	x	x	x	/xxxxxx	/xxx		
Converter (design of measuring ends of thermocouple: Single thermocouple, insulated end)	Converter type		Galvanic separation	Ex ia	NFC	Range [°C]														
	Analogue linear output signal with thermoelectric voltage	APAQ-HCF				Adjustable range													/HCF	
		APAQ-HCFX		•																/HCFX
	Programmable linear output signal with temperature	TH 200	•			Programmable range													/TH200	
		TH 200-ex	•	•																/TH200X
		IPAQ-H	•																	/IPAQH
		IPAQ-HX	•	•																/IPAQHx
		MINIPAQ-HLP																		/MINIPAQ
		IPAQ C202																		/C202
		IPAQ C202X			•															/C202X
		IPAQ C330					•													/C330
	Programmable with HART protocol linear output signal with temperature	IPAQ C330X			•	•													/C330X	
		IPAQ C520	•																/C520	
		IPAQ C520S ****)	•																/C520S	
		IPAQ C520X	•	•															/C520X	
		IPAQ C520XS****)	•	•															/C520XS	
		IPAQ C530	•			•													/C530	
		IPAQ C530X	•	•	•	•													/C530X	
		TH 300	•																/TH300	
		TH 300-ex	•		•														/TH300X	
MESO-H		•																/MESOH		
Other *)	MESO-HX	•	•															/MESOHX		
	248 HA NA	•																/248HANA		
	248 HA I1	•		•														/248HA1X		
	644 HA NA	•																/644HANA		
	644 HA I1	•		•														/644HA1X		
																			/99	
Without converter (for installation of the converter by customer)																		/00		
LED display to loop 4-20mA	LED display LPI-01 (only with converter, except 644 HANA)																		/LD	
	LED display Ex ia *) (only with converter Ex ia, except 644 HA1X)																		/LDX	

Standard design

- *) Only as a special requirement after an agreement with the manufacturer
- ***) Thermowells of this material are suitable for contact with food
- ***)  **WARNING**
Upper limit of measuring range is limited by the resistance used thermocouple (max. 1150°C for thermocouple K, max. 800°C for t thermocouple J, for other type of thermocouple is limited by upper limit of measuring range by the resistance of this thermocouple), the upper limit of the range is considered in hot air
- ****) Functional safety SIL2

TABLE 2 – ADDITIONAL REQUIREMENT FOR DESIGN OF TEMPERATURE SENSORS WITH METAL PROTECTIVE TUBE, TYPE 351

SPECIFICATIONS			CODE
CALIBRATION	NUMBER OF CALIBRATION POINTS	CALIBRATION RANGE	
Calibration by TPM 3342-94, define calibration points	3	0 to 800 °C	/Q4
	3	0 to 1100 °C	/Q42
	Other	0 to 1100 °C	/Q9
REQUIREMENT FOR OTHER DOCUMENTATION		USE	
EU Declaration of Conformity		for design with converter	/EU
Copy of EU-Type Examination Certificate acc to the 2014/34/EU (ATEX 114)		for Ex ia design	/Exi
Copy of the Inspection Certificate 3.1 acc to EN 10204 for material of protective tube with the heat number			/3.1
Declaration of Conformity with purchase order 2.1 pursuant to EN 10204			/2.1

Specify the code behind ordering number. Define calibration points for codes Q4, Q42 a Q9.

TABLE 3 - ACCESSORIES - to be ordered separately

SPECIFICATIONS			ORDERING NUMBER
Connecting flange	for protective tube Ø 14 mm		991 UP 14
	for protective tube Ø 22 mm or cantilevered metal tube of ceramic tube Ø 15 mm		991 UP 22
Nipple with threaded ring for protective tube Ø 14 mm	material	carbon steel 1.0122	991 NVP6 D14 13
		stainless steel 1.4541	991 NVP6 D14 72
Nipple with threaded ring for protective tube Ø 22 mm or cantilevered metal tube of ceramic tube Ø 15 mm	material	carbon steel 1.0122	991 NVP6 D22 13
		stainless steel 1.4541	991 NVP6 D22 72

INSTALLATION AND CONNECTION

SENSOR INSTALLATION

The sensor installation is realized by means of a connecting flange or by means of a nipple with a threaded ring.

SENSOR WITH METAL PROTECTIVE TUBE INSTALLATION

For high temperatures, we recommend installing the sensor in a vertical position

SENSOR WITH CERAMIC PROTECTIVE TUBE INSTALLATION



WARNING

Fix sensor to the cantilevered metal tube!

Install the sensor so that the cement joint is out of reach of high temperatures due to the different thermal expansion of the cantilevered metal tube and the ceramic protective tube.

When installing or changing the sensors during operation, slide them in and out of the high-temperature environment gradually (about 20 mm in 1 minute) to avoid rupture ceramic protective tubes due to thermal stress caused by a rapid temperature change.

If slow sensor movement is not possible, ensure at least its slow and even preheating.

FLANGE INSTALLATION

Weld the bottom part of the flange into the wall of the technological equipment. In the connecting flange, you can move the sensor after releasing two screws M6x14, whereby you can achieve the required immersion of the sensor.

CONNECTING FLANGE 991 UP 14 A 991 UP 22

(quotation for 991 UP 22 in parentheses)

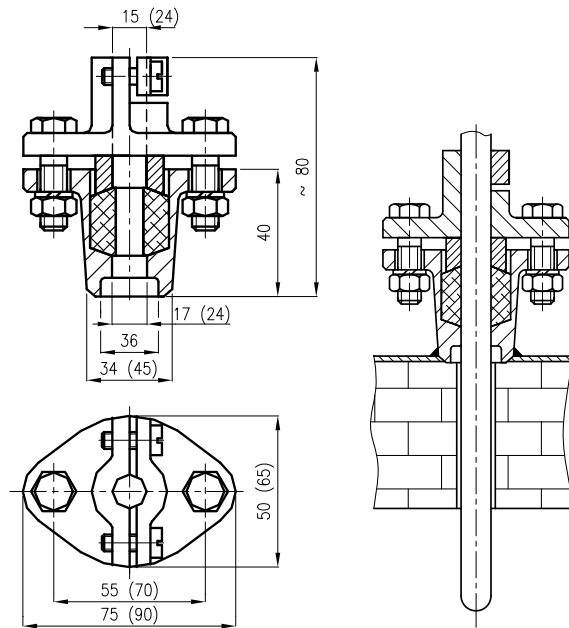

INSTALLATION OF THE NIPPLE WITH A THREADED RING shall be made pursuant to the instructional label as follows:

1. Uninstall the complete nipple by unscrewing the cap-nut.
2. Weld the nipple itself (after possible shortening) onto the wall of the piping or other technological equipment.
3. Put the following pieces on the metal protective tube of the temperature sensor in the said order: cap-nut, thrust ring and threaded ring.
4. Insert the temperature sensor with put-on pieces pursuant to point 3 into the prepared nipple and only after the definitive selection of immersion, tighten it duly with a torque wrench (torque 60-70 Nm for tube diameter 14, 100 Nm for tube diameter 22).



WARNING:

The length of the immersion part cannot be changed repeatedly; the sensor can only be uninstalled!

With respect to maintaining metrological properties and the longest possible service life, it is not recommended to install the sensors in places with high turbulence of the medium, which is caused e.g. by a rapid transition from a small

diameter of the piping to a larger one (when failing to comply with the required shape and dimensions of diffuser behind the flow meter), etc. Recommended distance of the temperature sensor from the installation flange of the flow meter is min. 1 m.

NIPPLE WITH THREADED RING

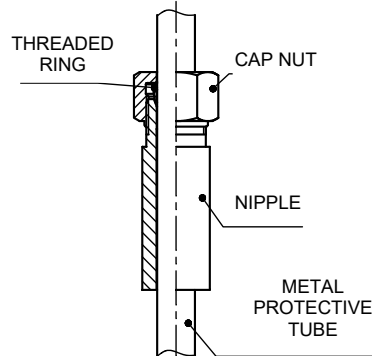

ELECTRICAL CONNECTION

The terminal board of the sensor (converter) is accessible after tilting away the lid of the head, which is connected with one screw.

Connect the evaluation devices to the sensor with a non-armoured cable with double insulation with outer diameter 5 to 8 mm, internal wires with Cu core (sensor with converter) or compensation wiring (sensor without converter) with cross section 0.5 to 1.5 mm². Seal the cable outlet of the sensor adequately.



WARNING

Do not use independent wires without jacket for electrical connection. To ensure the Ingress Protection grade in the outlet, the connecting cable shall have circular cross-section. Temperature resistance of the cable shall comply with the ambient temperature!

The cable insulation shall have chemical and mechanical resistances in compliance with the conditions, in which the cable will be installed. It is recommended supporting the cable along its length between the sensor and the follow-up device. In the environment with interfering signals, use shielded cable in the power supply circuit. Shielding may be only grounded (earthed) in one point. The cable should not be placed together with power cables.

In case of the sensor with HART protocol converter, the maximum length of wiring is defined by the arrangement of wires of the connecting cable. The total length of wiring may be up to 1500 m. It requires a twisted two-wire with shared shielding with the diameter of the cross section of the core min. 0.5 mm². The HART communicator is connected to the supply loop of the sensor with converter pursuant to Figure 3.

To achieve reliable communication, the total load resistance of min. 250 Ω shall be in the circuit of the output loop.

INSTALLATION OF THE SENSOR WITH CONVERTER Ex i IN ENVIRONMENT WITH EXPLOSIVE GASEOUS ATMOSPHERE

The installation of the sensor in the environment with explosive gaseous atmosphere shall comply with the requirements of EN 60079-14.

The sensor with converter Ex ia may be used in case of compliance with the parameters Ex ia of the converter according to the enclosed converter manual.

Only insulated cables must be used in intrinsically safe circuits which is able to withstand the electrical strength test with a voltage equal to twice the voltage in the intrinsically safe circuit, or 500 V eff (DC 750 V), taking greater of the values.

In case of installation of intrinsically safe circuits, including cables, the maximum permitted inductance, capacity or ratio L/R and surface temperature may not be exceeded. Permitted values can be found out in the documentation of the follow-up equipment or label with the designation. Locate the follow-up equipment outside of the dangerous area. An intrinsically safe source must be always used that is approved for power supply of intrinsically safe equipment in the sense of EN 60079-11. If a LED display is required, it must be in the design Ex ia.

! WARNING

The programmable converter may not be connected to the PC or HART communicator if the converter is located in the explosive environment.

Shielding of the cable of the intrinsically safe circuit must be grounded in the same place as the intrinsically safe circuit, the connection must be outside the dangerous area. For the installations in dangerous areas, mutual interconnection is required (bringing to the same potential). To achieve it, terminals on the sensor head can be used. The sensor need not be connected to the system of mutual interconnection separately if it is installed firmly and has metal interconnection with the structural parts or the piping, which is connected to the system of mutual interconnection.

HEAD OF THE SENSOR WITH TERMINALS

(for sensor without converter or with converter Ex ia)

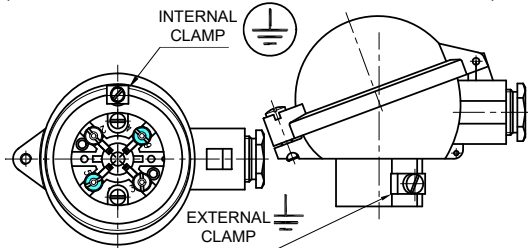

Maximum cross-section of wire for connection to external and internal terminals:

Internal terminal: stranded wire 1.5 mm², full wire 2.5 mm²
 External terminal: stranded wire 4.0 mm², full wire 6.0 mm²
 If stranded wires are used for the interconnection, they shall be protected against fraying with pressing hollow.

COMMISSIONING

After the installation of the sensor, including closing the fixed closure and connection of the follow-up (evaluation) device to the supply voltage (and the settlement period of the converter), the equipment is prepared for operation.

! WARNING



After finish installation of the sensor in the environment with explosive gaseous atmosphere the default device revision and installation must be performed in EN 60079-17.

OPERATION AND MAINTENANCE

The sensor does not require any operation and maintenance. For the sensor in the environment with explosive gaseous atmosphere maintenance and following regular periodic revisions or continuous supervision of professional personnel are carried out compliance with EN 60079-17.

SENSOR UNINSTALLATION

Disconnect the sensor from the power supply source. The terminal board of the sensor (converter) is accessible after tilting away the lid of the head, which is connected with one screw.

The measuring insert of the sensor is replaceable and is uninstalled from the head after disconnecting the cable by releasing two screws.

If the sensor is connected to the system of interconnection, the wire for mutual interconnection shall be released from the terminal on the head of the sensor before the complete uninstallation of the sensor.

After releasing the screws on the connecting flange (unscrewing the nut on the weld-on piece with threaded rings, remove the sensor.

REPAIRS

The sensors shall be repaired by the manufacturer. They shall be sent for repair in the original or equal package without accessories.

SPARE PARTS

Spare parts shall be delivered by the manufacturer. Relevant measuring inserts can be ordered pursuant to the following table:

SPECIFICATIONS		ORDERING NUMBER					
		MV350	/xxx/	1	x	x	/xxxx
Length of measuring insert [mm]			acc. to table 1	1			
Sensing probe	Thermocouple K				K		
	Thermocouple J				J		
	Other thermocouple*)				9		
Accuracy class	1					1	
	2					2	
Connection of terminal board and design of measuring ends of the thermocouple or converter	Single thermocouple insulated end			1			/JI
	Double thermocouple independent end			1			/JIX **)
	Converter acc. to tab. 1						/DU
							/DUX**)
							/converter

*) Only as a special request after agreement with the manufacturer
 **) Ex ia design (only for TC "K" a "J", with measuring insert ø 6, length of measuring insert Lmv 100 – 3025 [mm])

PURCHASE ORDER EXAMPLE OF MEASURING INSERT

Thermoelectric measuring insert without converter
 MV350 /735/ 1K2/JI
 6 pcs

To order the certified measuring inserts, specify the code according to Table 2 – Additional requirements – behind the ordering number.

The measuring inserts are marked according to Article DESIGNATION. Designation is completed with the ordering number.

Each delivery includes

- Delivery note
- Measuring insert pursuant to the purchase order
- Optional accessories to the measuring insert with a programmable converter
 - o Configuration program according to the required converter
 - o Communication modem (for serial port RS 232C) according to the required converter
- Accompanying technical documentation in Czech
 - o Product quality and completeness certificate, which also serves as the warranty certificate
 - o EC Declaration of Conformity (for Ex ia design)
 - o Calibration sheet (for calibrated design)
 - o Product manual

If it is established in the purchase contract or agreed otherwise, the following documentation can be also delivered with the product

- Declaration of Conformity of the supplier according to EN ISO/IEC 17050-1
- EC Declaration of Conformity (for design with converter)
- Copy of EC Type Examination Certificate according to the Directive No 2014/34/EU. (ATEX) for Ex ia design

WARRANTY

The warranty period is 24 months from the receiving of the product by the customer, unless established otherwise in the contract. Rejection of defects shall be enforced in writing at the manufacturer within the warranty period. The rejecting side shall identify the product name, ordering and manufacturing numbers, date of issue and number of the delivery note, clear description of the occurring defect and the subject of the claim. If the rejecting side is invited to send the device for repair, it shall do so in the original package of the manufacturer and/or in another package ensuring safe transport.

The warranty shall not apply to defects caused by unauthorized intervention into the device, its forced mechanical damage or failure to comply with operation conditions of the product and the product manual.

DISABLING AND LIQUIDATION

The product and its package do not include any parts that could impact the environment.

Products that are withdrawn from operation, including their packages (with the exception of products marked as electrical equipment for the purposes of return withdrawal and separate salvage of electrical waste), may be disposed of to sorted or unsorted waste pursuant to the type of waste.

The manufacturer realizes free return withdrawal of marked electrical equipment (from 13.8.2005) from the consumer and points out the danger connected with their illegal disposal. The package of the sensor can be recycled completely. Metal parts of the products are recycled, non-recyclable plastic materials and electrical waste shall be disposed of in accordance with applicable legislation.

FIGURE 1 - DESIGN OF MEASURING ENDS OF JACKETED THERMOCOUPLES (SCHEMATIC ILLUSTRATION)

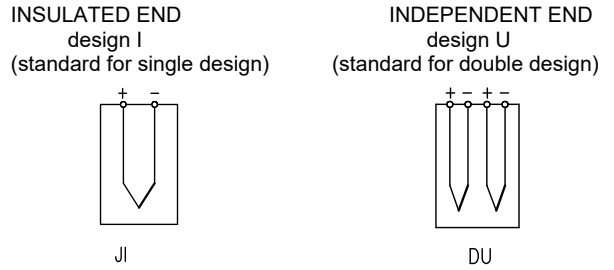
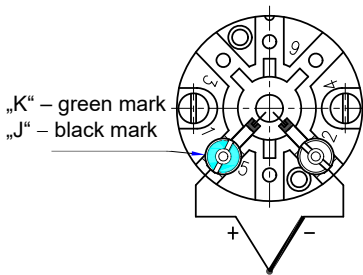

FIGURE 2 - SCHEME OF CONNECTION OF TEMPERATURE SENSORS

SCHEME OF CONNECTION WITHOUT CONVERTER

with single thermocouple



with double thermocouple

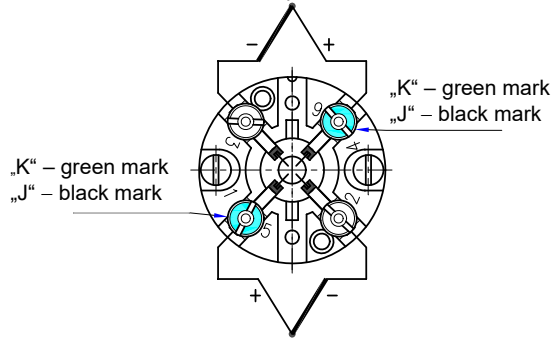

SCHEME OF CONNECTION WITH CONVERTER AND DISPLAY

without converter

with converter with HART protocol

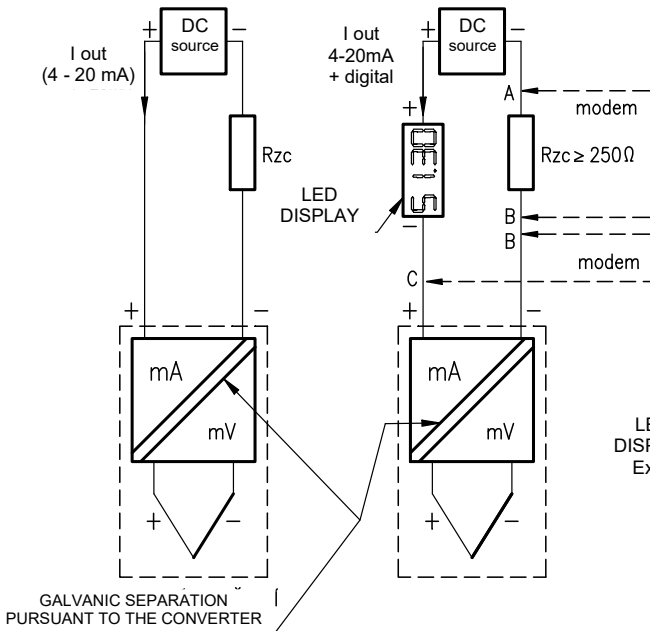

A-B and B-C options of connection of the control unit (HART modem, HART communicator)

Rzc – total load resistance

with converter Ex ia

with converter Ex ia with HART protocol

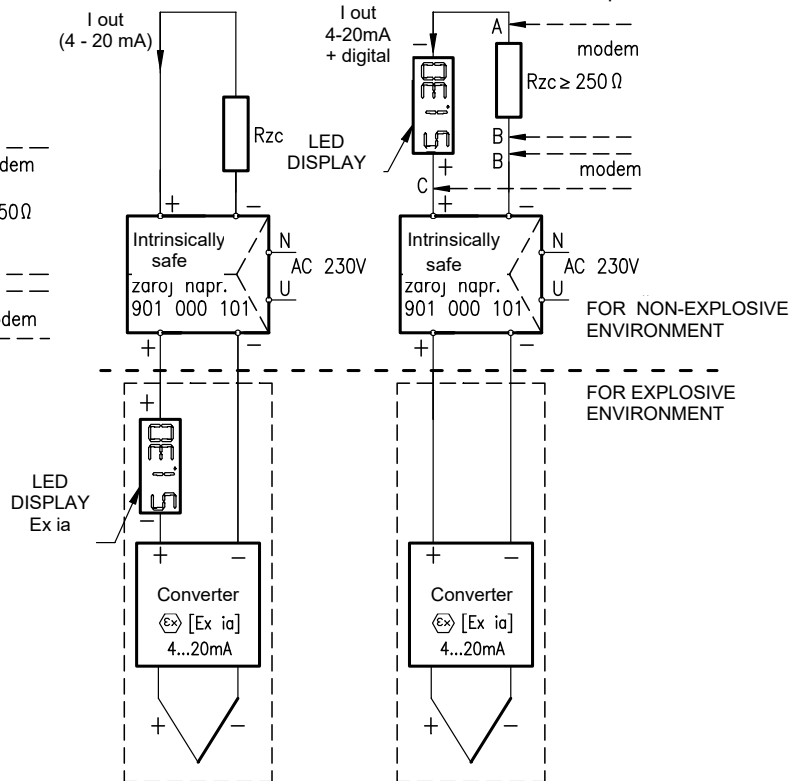

FIGURE 3 – EXAMPLE OF OPERATION CONNECTION OF TEMPERATURE SENSOR WITH CONVERTER IN LOOP 4 - 20 mA

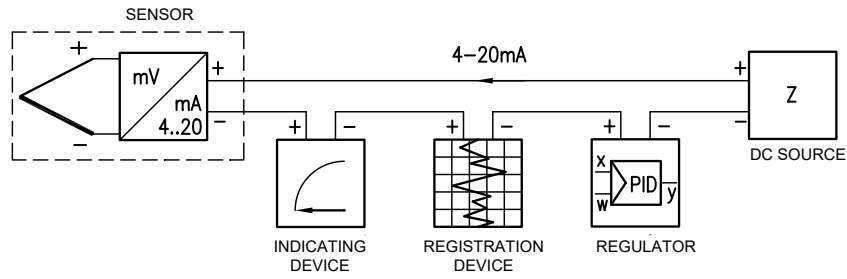
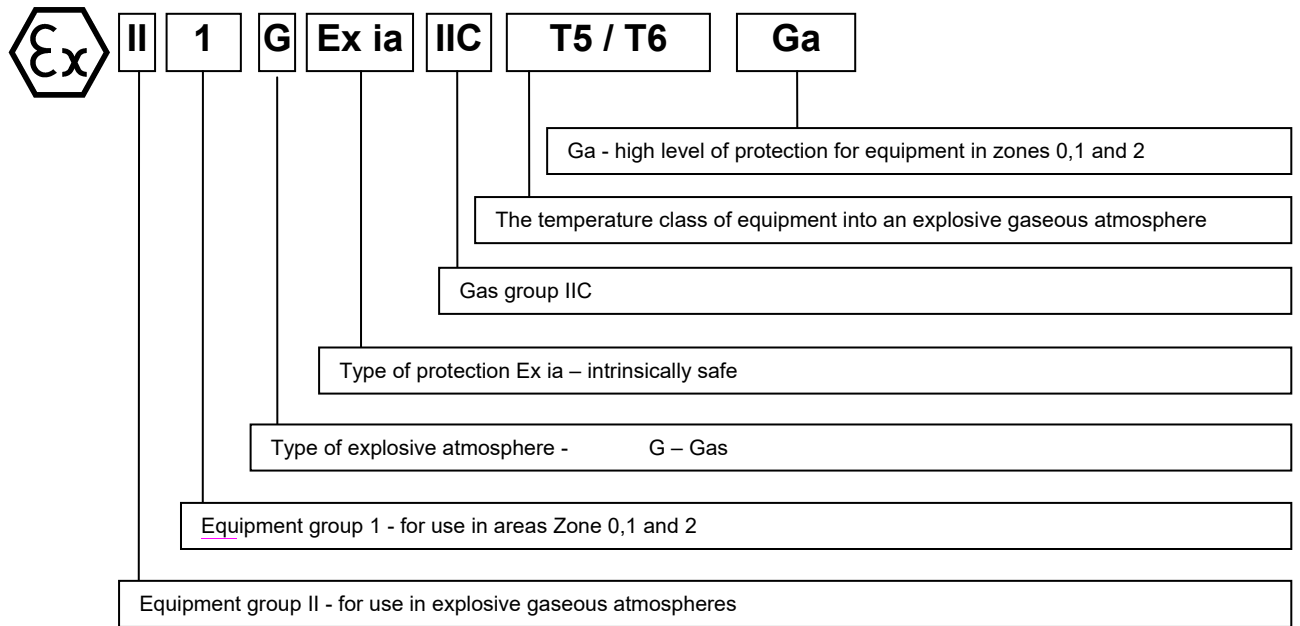

FIGURE 4 - INTRINSICALLY SAFE MARKING



April 2021

© ZPA Nová Paka, a.s.

