



# Thermoelectric temperature sensor with cable outlet, for plastics

## PRODUCT MANUAL

### type 302

#### APPLICATION

- For remote measurement of temperature, especially for measurement of temperature of the plasticizing cylinder of machines for processing plastic materials and for other similar applications when the sensor is installed into the bore of the measured equipment

#### DESCRIPTION

The temperature sensor consists of a jacket thermoelectric couple with connected compensation wiring. The sensor is spring-loaded and union with bayonet closure is used for its connection. The immersion of the sensor can be adjusted within the range from 20 to 120 mm.

To measure temperature, a defined change of thermoelectric voltage of the thermocouple in dependence on the change of temperature of the measured environment is used.

#### TECHNICAL DATA

The sensor is designed pursuant to EN 61140 as an electrical equipment of protection class III for the application in networks with the category of overvoltage in the installation II and pollution grade 2 pursuant to EN 61010-1. The follow-up (evaluation) device shall comply with Article 6.3 of the said standard.

**Measuring range:** 0 to 400 °C  
**Electrical strength** pursuant to EN 61010-1 Article 6.8.3: 500 V eff  
**Electrical insulation resistance** pursuant to EN 61515: min. 1000 MΩ, at ambient temperature 20 ±15 °C and max. 80 % relative humidity

**Ingress protection** pursuant to EN 60529: IP 60  
**Operation position:** discretionary  
**Type of operation:** continuous  
**Sensor weight with compensation wiring:**  
 L<sub>1</sub> 1,5m approx. 0,135 kg  
 3,0m 0,200 kg

**Applied materials:**  
 Stem tube INCONEL 600  
 Movable bayonet fitting steel of class 17  
 Compensation wiring insulation from glass fibres, external braid from galvanized steel wire

#### OPERATION CONDITIONS

The environment is defined by the group of parameters and their severity grades IE 36 pursuant to EN 60721-3-3 and the following operation conditions.

**Temperature of stem of the sensor in the place of connection of the compensation wiring:** continually max. 180 °C

**Relative ambient humidity:** 10 to 100 % with condensation, with upper limit of water content of 29 g H<sub>2</sub>O/kg of dry air

**Atmospheric pressure:** 70 to 106 kPa  
**Vibrations:** Frequency range 10 to 500 Hz  
 Drift amplitude 0.075 mm  
 Acceleration amplitude 10.0 ms<sup>-2</sup>

#### METROLOGICAL DATA

**Probe:** thermoelectric couple J (Fe-CuNi) or K (NiCr-Ni) pursuant to EN 60584-1, Ø 4,5 mm, tolerance class 2, single with isolated or independent measuring end

**Calibration depth of immersion:** 600 mm  
**Temperature response time** pursuant to EN 60751 in whirling water (characteristic value) without thermowell (separate measuring insert):

Grounded design	τ <sub>0,5</sub>	1.0 s
	τ <sub>0,9</sub>	2.5 s
Isolated design	τ <sub>0,5</sub>	1.5 s
	τ <sub>0,9</sub>	3.4 s

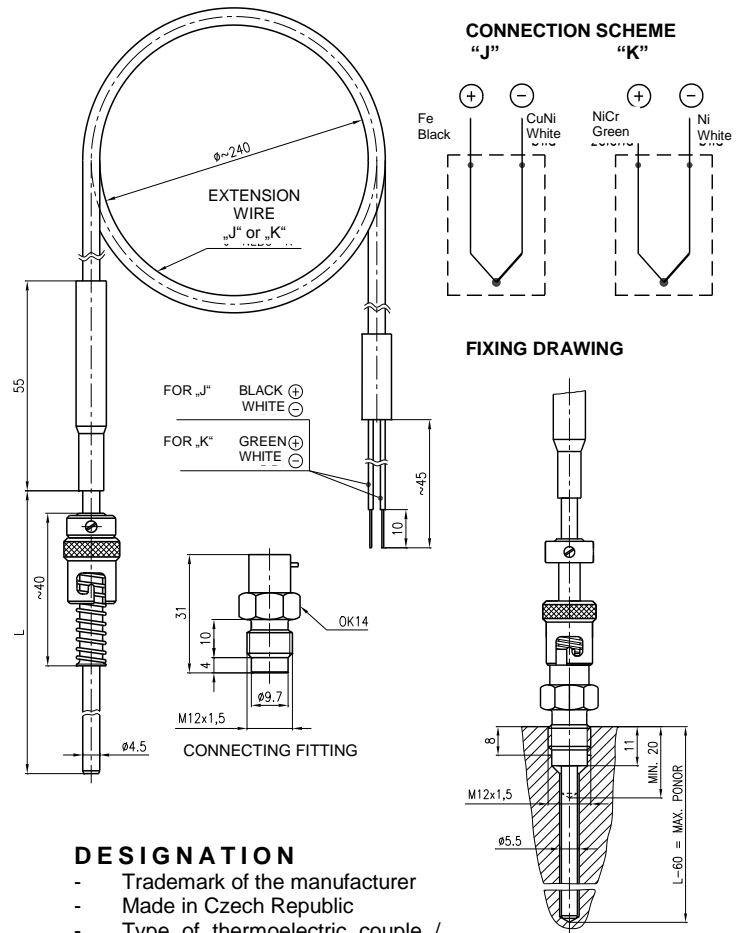

#### DESIGNATION

- Trademark of the manufacturer
- Made in Czech Republic
- Type of thermoelectric couple / tolerance class
- Measuring range
- Product ordering number
- Ingress protection

#### DELIVERY

Unless agreed otherwise with the customer, each delivery includes:

- Delivery note
- Sensor pursuant to the purchase order
- Accompanying technical documentation in Czech:
  - o Product manual
  - o Product quality and completeness certificate, which also serves as the warranty certificate
  - o Calibration sheet (for calibrated design)

If it is established in the purchase contract or agreed otherwise, the following documentation may be also delivered with the product:

#### CALIBRATION

The calibration is realized pursuant to TPM 3322-94 and in compliance with EN 60584-1, usually in three temperature points evenly distributed in the operation range of the sensor or in the points according to the requirement of the customer. Calibration sheet with measured data is issued for calibrated sensors.

#### RELIABILITY

Indicators of reliability in operation conditions and conditions of the environment specified herein

- Mean time of operation between failures 96 000 hours
- Expected service life 10 years

**DESIGN OF TEMPERATURE SENSORS**

SPECIFICATIONS		ORDERING NUMBER						
		302	x	0	x	x	0	x
Stem length L [mm]	120 (min. immersion 20mm, max. immersion 60mm)		1					
	170 (min. immersion 20mm, max. immersion 110mm)		2					
	Other *)		9					
Thermoelectric couple Ø 4,5mm	J (Fe-CuNi)	pursuant to EN 60584-1, tolerance class 2		0	1			
	K (NiCr-NiAl)			0	2			
	with isolated end					1		
	with grounded end					2		
Length of compensation wiring L <sub>1</sub> [m]	1,5					0	1	
	3,0					0	2	
	Other *)					0	9	

\*) Only as a special requirement after an agreement with the manufacturer

**ORDERING**

The purchase order shall specify

- Name
- Product ordering number
- If calibration is required and in what temperature points
- Other (special) requirements
- Number of pieces

**PURCHASE ORDER EXAMPLE**

**Standard design**

Thermoelectric temperature sensor for plastics with cable outlet  
302 101 101  
6 pcs

**Special requirement:**

Thermoelectric temperature sensor for plastics with cable outlet  
302 901 109  
6 pcs  
length of compensation wiring 5 m  
length of stem 200 mm

**PACKING**

Both sensors and accessories are delivered in a packing ensuring resistance to the impact of thermal effects and mechanical effects pursuant to controlled packing regulations.

**TRANSPORT**

The sensors may be transported on conditions corresponding to the set of combinations of classes IE 21 pursuant to EN 60721-3-2 (i.e. by airplanes and trucks, in premises that are ventilated and protected against atmospheric conditions).

**STORAGE**

The sensors may be stored on conditions corresponding to the set of combinations of classes IE 11/1K3 pursuant to EN 60721-3-1 (i.e. in places with uninterrupted temperature control from - 5 to 45 °C and humidity from 5 to 95%, without a special threat of an attack with biological agents, with vibrations of small significance and not situated close to sources of dust and sand).

**INSTALLATION AND CONNECTION**

The sensors are installed in bores of plastic machines by means of a bayonet connection. The required nominal length is set by means of two set screws on the movable bayonet connection. When setting, it is necessary to observe the condition of the sensor stem suspension in the bore. The operation position of the sensors is discretionary.

**ELECTRICAL CONNECTION**

The electrical connection may be only realized by qualified workers.

Connect the sensor to the evaluation device either directly by the connection of the compensation wiring to the applicable terminals with inner compensation of the device with inner compensation or to the terminals of the compensation box (or thermostat of comparison connections) and further by connecting wiring to the terminals of devices without inner compensation.

During the installation of connecting fitting, torque of 10 Nm is recommended

**COMMISSIONING**

After the sensor installation and connection of the follow-up (evaluation) device to the supply voltage, the equipment is prepared for operation.

**OPERATION AND MAINTENANCE**

The sensor does not require any operation and maintenance.

**SPARE PARTS**

The design of the sensor does not require any delivery of spare parts.

**WARRANTY**

The warranty period is 24 months from the receiving of the product by the customer, unless established otherwise in the contract. The rejection of defects shall be enforced in writing at the manufacturer within the warranty period. The rejecting side shall identify the product name, ordering and manufacturing numbers, date of issue and number of the delivery note, clear description of the occurring defect and the subject of the claim. If the rejecting side is invited to send the device for repair, it shall do so in the original package of the manufacturer and/or in another package ensuring safe transport.

The warranty shall not apply to defects caused by unauthorized intervention into the device, its forced mechanical damage or failure to comply with operation conditions of the product and the product manual.

**REPAIRS**

The sensors shall be repaired by the manufacturer. They shall be sent for repair in the original or equal package without accessories.

**DISABLING AND LIQUIDATION**

Both the product and its package do not include any parts that could impact the environment.

Products that are withdrawn from operation, including their packages (with the exception of products marked as electrical equipment for the purposes of return withdrawal and selected salvage of electrical waste), may be disposed of to the sorted or unsorted waste pursuant to the type of waste.

The manufacturer realizes free return withdrawal of marked electrical equipment (from 13.8.2005) from the consumer and points out the danger connected with their illegal disposal. The package of the sensor can be recycled completely.

Metal parts of the products are recycled, non-recyclable plastic materials and electrical waste shall be disposed of in accordance with applicable legislation.

**FIGURE 1 – DESIGN OF MEASURING END OF JACKET THERMOCOUPLES (SCHEME DIAGRAM)**

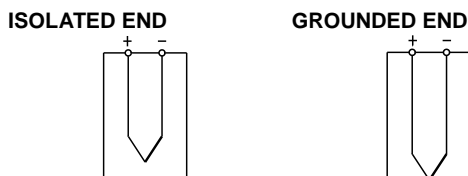



March 2018  
© ZPA Nová Paka, a.s.

ZPA Nová Paka, a.s.  
Pražská 470  
509 39 Nová Paka

tel.: spojovatel: 493 761 111  
fax: 493 721 194  
e-mail: obchod@zpanp.cz

3 / 3

[www.zpanp.cz](http://www.zpanp.cz)  
bankovní spojení: ČSOB HK  
číslo účtu: 271 992 523/300

IČO: 46 50 48 26  
DIČ: CZ46504826