



# PRODUCT MANUAL

## Thermoelectric temperature sensor to without converter or with converter type series 340 type 341

FOR DESIGN WITH CONVERTER A MANUAL IS ENCLOSED TO THE RELEVANT CONVERTER  
FOR DESIGN WITH CONVERTER AND DISPLAY A MANUAL IS ENCLOSED TO THE RELEVANT CONVERTER AND DISPLAY

### APPLICATION

- For exact remote measurement of temperature of steady and running liquids (gases and fluids), for which the properties of the thermowell of the sensor selected by the customer are suitable; measurement may be realized up to temperature and pressure determined by thermowell resistance
- For explosive environment in premises Zone 2, Zone 1 and Zone 0 pursuant to EN 60079-10 when using the converter Ex ia or when connecting to do Ex ia circuit
- In a set with control or diagnostic systems for process monitoring
- In design with converter for transfer of resistance sensor signal to unified output signal 4 to 20 mA or digital signal (converter with HART protocol)
- In design with display to display the value of the measured value immediately
- For the environment, where mechanical resistance is required pursuant to EN 60068-2-6 (class AH2) and seismic capability of the electrical equipment of the safety system of the nuclear power stations pursuant to IEC 980 (MVZ level SL-2)

The sensors with converter are rated products pursuant to the Directive 2014/30/EU of the European Parliament and the Council and EU Declaration of Conformity **EU -231000** is issued for them.

### DESCRIPTION

The sensor consists of a replaceable measuring insert with a flange and a ceramic terminal board or installed two-wire converter (insulated or non-insulated, even in design Ex ia) and protective armature consisting of a head and an adapter with a screw union for the connection of the sensor into the thermowell selected by the customer. The head is provided with a lid and a cable gland for the connecting wiring. The terminal board of the sensor (converter) is accessible after tilting of the lid of the head that is connected with one screw. The sensor with converter with Ex ia design is provided with external and internal terminals on the head for the connection of ground wire or wire for mutual interconnection. The converter is installed either directly on the flange of the measuring insert or in the lid of the head. The sensor with converter is supplied from an external source. The installed converter is pre-set to the required range at the sensor manufacturer. To measure temperature, a defined change of sensor resistance in dependence on the change of temperature of the measured environment is used.

### TECHNICAL DATA

The sensor dimensions are based on the original ČSN 25 8301. The sensor is designed pursuant to EN 61140 as an electrical equipment of protection class III for the application in networks with category of overvoltage in installation II and pollution grade 2 pursuant to EN 61010-1; the follow-up (evaluation) device shall comply with Article 6.3 thereof.

#### Measuring range:

Min. adapter length $L_n$ [mm]	Type of thermocouple	Measuring range [°C]
150	J	-200 to 800 *)
	K	-200 to 1150 *)
80	J, K	-200 to 250

\*) The upper limit of the measuring range is limited by resistance of the material of the used thermowell.

Measuring range of the sensor with converter is established by the range of the selected converter.

#### Electric strength pursuant to EN 61010-1, Article 6.8.3:

500 V eff (only measuring insert without converter or design with insulated converter)

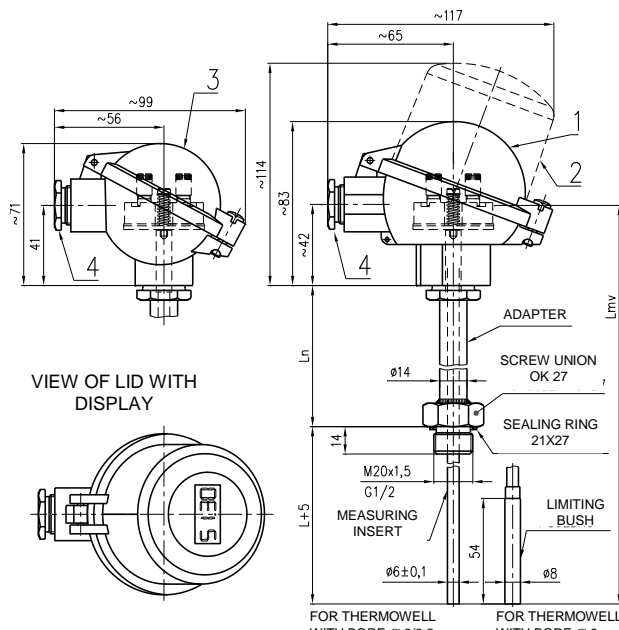

- 1 - Ball head (Al alloy) (for converter Ex i with external and internal terminals) or plastic ball head (it may not be used for converter Ex i)
  - 2 - Ball head with increased lid (Al alloy) without display for converter in the lid or with display (for converter Ex i with external and internal terminals)
  - 3 - Small ball head (Al alloy) (only for the terminal board)
  - 4 - Cable gland M20x1.5
- L nominal length  
 $L_n$  length of adapter  
 $L_{mv}$  length of measuring insert

#### Electric insulation resistance pursuant to EN 61515, Article 5.3.2.4:

min. 1000 M $\Omega$ , at ambient temperature 20 $\pm$ 15°C and max. 80% relative humidity, test voltage 500 V DC

#### Power supply of converter:

DC 24 V from source SELV, e.g. INAP 16 and INAP 901

#### Other data of the converter:

refer to the enclosed manual

**Display:** LED display to loop 4-20mA  
 other date refer to enclosed manual

#### Ingress protection pursuant to EN 60529: IP65

#### Operation position:

discretionary, the gland shall not be situated upwards  
 continuous

#### Type of operation:

#### Sensor weight:

with ball head (Al alloy), adapter 150 mm and nominal length 250 mm  
 approx 0.68 kg

#### Used materials:

Stem tube of measuring insert	for thermocouple of type "J"	Steel 1.4541
	for thermocouple of type "K"	INCONEL 600
Adapter		Steel 1.4541
HEAD		Aluminium alloy painted with polyester paint
		plastic PPO (phenyl polyoxide)
Sealing of lid of head and gland		Oil-resistant rubber
Head terminals of terminal board		Brass with Ni surface
Connecting items of sensor		Stainless steel

**OPERATION CONDITIONS**

The environment is defined by the group of parameters and their severity grades IE 36 pursuant to EN 60721-3-3 and the following operation conditions.

**Ambient temperature for head and gland of the sensor:**

- for design without converter -50 °C to 120 °C
- for design with converter pursuant to the type of the converter (refer to the enclosed manual of the converter)
- for design with converter and display pursuant to the type of the converter and display (refer to enclosed converter and display manual)

**Relative ambient humidity:**

- 10 to 100 % with condensation, with upper limit of water content 29 g H<sub>2</sub>O/kg of dry air
- For design with converter pursuant to type of converter (refer to enclosed converter manual)
- For design with converter and display (refer to enclosed converter and display manual)

**Atmospheric pressure:** 70 to 106 kPa

**Vibrations:**

Sensor	with converter			without converter		
	100, 160	250, 400	630	100, 160	250, 400	630
Nominal length L [mm]	100, 160	250, 400	630	100, 160	250, 400	630
Frequency range [Hz]	10 to 500					
Drift amplitude [mm]	0.2	0.15	0.075	0.5	0.2	0.075
Acceleration amplitude [ms <sup>-2</sup> ]	29.4	19.6	9.8	68.7	39.2	9.8

**Maximum speed of flow of liquids:**

pursuant to parameters of thermowell used by the customer

**Resistance of material of the head PPO (phenyl polyoxide):**

Kerosene	partially resistant
Diesel oil	resistant
Benzene	partially resistant
Animal and vegetable oil	resistant
Weak hydroxydes	
Strong hydroxides	
Weak acids	
Strong acids	
Sea water	partially resistant
Trichloroethylene	

**Resistance of lid sealing material (oil resistant rubber):**

Spirit	resistant
Ether	
Benzole	
Petrol	
Ester	
Animal and vegetable oil	
Mineral oil	
Diesel oil	
Weak alkali hydroxydes	
Strong alkali hydroxides	
Weak acids	resistant
Strong acids	not resistant
Sea water	resistant
Trichloroethylene	partially resistant
Hot water	

**METROLOGICAL DATA**

**Sensing probe:** measuring thermocouple J (Fe-CuNi) or K (NiCr-NiAl) pursuant to EN 60584-1, Ø 6 or Ø 3 mm, tolerance class 2 or 1, with insulated measuring end or double with independent measuring end

**Output signal**

of the analogue converter (linear with thermoelectric voltage):  
4 to 20 mA

of the programmable converter (linear with measured temperature):  
4 to 20 mA (+ digital for HART protocol)

**Calibration depth of immersion of the measuring insert of the sensor**

for temperature points within range -70 to 250°C:  
200 mm (min. 160 mm)

for temperature points over 250°C:  
300 mm (min. 260 mm)

The distance of flange of the measuring insert from the level of medium in the calibration bath shall be at least 40 mm at

temperatures to 250°C and min. 70 mm at temperatures above 250°C.

**Temperature response time** pursuant to EN 60751 in whirling water (characteristic value):

without thermowell (independent measuring insert)

with thermowells 99110.....,99111.....,99112... and 99113... (L = 160)

with thermowells 99110.....,99111.....,99112... and 991130... (L = 250, 400, 630)

with thermowell 991150...(L = 160)

with thermowell 991170...(L = 160)

**Temperature response time** pursuant to EN 60751 in whirling water for measuring insert Ø 3 mm (characteristic value):  
Without thermowell (independent meas. insert)

with thermowell 991180...(L = 160)

**DESIGNATION :**

**Data on label of head**

- Trademark of the manufacturer
- Made in Czech Republic
- Type of the thermoelectric sensor / tolerance class
- Measuring range or adjustable range of the converter
- Product ordering number
- Ingress protection
- Time code (Serial number for calibrated design, design with tolerance class 1, design with converter)
- Output signal 4 to 20 mA (design with converter)
- Ambient temperature
- Designation of non-explosiveness and EU Type Examination Certificate number(for design with converter Ex ia)
- CE mark (for design with converter)

**Data on label of measuring insert**

- Trademark
- Type of sensor
- Time code (Serial number for calibrated design, design with tolerance class 1, design with converter)

**Data on converter label**

- Trademark
- Type of sensor
- Pre-set temperature range
- Designation of non-explosiveness and EU-Type Examination Certificate number for design with converter Ex ia
- CE mark with identification number of the notified person (for design with converter Ex ia)

**Data on display**

- Trademark
- Designation of non-explosiveness and EU-Type Examination Certificate number (for design with converter EX ia)
- CE mark with identification number of the notified person (for design with converter)

**CERTIFICATION**

- Non-explosiveness Ex ia, EU-Type Examination Certificate pursuant to the 2014/34/EU, (pursuant to the type of the converter and display)

**RELIABILITY**

Reliability indicators in operation conditions and ambient conditions specified herein

- Mean time of operation between failures 96 000 hours (inf. value)

Expected service life 10 years

**DELIVERY**

Unless agreed otherwise with the customer, each delivery includes

- Delivery note
- Sensor pursuant to the purchase order
- Sealing ring 21x27 TPD 62-014-91
- Suitable thermowells and nipples ordered separately pursuant to the catalogue of accessories, type 991
- Optional accessories to sensor with programmable converter
  - o Configuration (parameterization) programme pursuant to the required converter
  - o Communication modem (for serial port RS 232C) pursuant to the required converter
- Accompanying technical documentation in Czech
  - o Product manual
  - o Product quality and completeness certificate, which also serves as the warranty certificate
  - o EU Declaration of Conformity (for design with converter Ex ia)

If it is established in the purchase contract or agreed otherwise, the following documentation can be also delivered with the product

- Declaration of Conformity with purchase order 2.1 acc. to EN 10204
- EU Declaration of Conformity (for design with converter)
- Calibration sheet (for uncertified calibrated design)
- Copy of EU-Type Examination Certificate pursuant to the Directive No 2014/34/EU for design with converter and display Ex ia

**CALIBRATION**

It is realized pursuant to TPM 3342-94 and in compliance with EN 60584-1, usually in three temperature points evenly distributed within the operation range of the sensor or in the points according to the requirement of the customer. Calibration sheets with measured data are issued for calibrated sensors.

**PACKING**

Both sensors and accessories are delivered in a packing ensuring resistance to the impact of thermal effects and mechanical effects pursuant to controlled packing regulations.

**TRANSPORT**

The sensors may be transported on conditions corresponding to the set of combinations of classes IE 21 pursuant to EN 60721-3-2 (i.e. by airplanes and trucks, in premises that are ventilated and protected against atmospheric effects).

**STORAGE**

The sensors may be stored on conditions corresponding to the set of combinations of classes IE 12 pursuant to EN 60721-3-1, but with ambient temperature from -20 to 70 °C (i.e. in places where temperature and humidity are not regulated, with a threat of occurrence of condensation, dripping water and formation of ice, without a special threat of an attack with biological agents, with vibrations of small significance and not situated close to sources of dust and sand).

**ORDERING TEMPERATURE SENSORS**

The purchase order shall specify

- Name
- Product ordering number
- Additional requirements for sensor design pursuant to Table 2
- Request for other documentation pursuant to Table 2
- Measuring range
- If calibration is required and in what temperature points
- If the delivery of thermowell and nipple pursuant to the type 991 is required for the sensor as accessories
- If optional accessories to the sensor with programmable converter are required
- Request for other documentation according to Article DELIVERY
- Other (special) requirements
- Number of pieces

Behind the ordering number specified pursuant to the table 1, the customer shall identify the required range of measured temperature (i.e. lower and upper temperature limits in °C) and, as the case may be, other non-standard required parameters for converter configuration (e.g. indication of sensor tripping, dampening, required designation - tagging etc.).

**PURCHASE ORDER EXAMPLE****Standard design:**

Thermoelectric temperature sensor to thermowell ČSN without converter  
341 410 231 K2/JI/Q42  
Calibration points 600, 800 and 1000°C  
Range -200 to 1150°C  
6 pcs

**Special request:**

Thermoelectric temperature sensor to thermowell ČSN with converter  
341 910 331 J2/HCF  
Nominal length L 380 mm  
Range 0 to 300°C  
6 pcs

**ORDERING ACCESSORIES**

The purchase order shall specify:

- Name
- Ordering number
- Number of pieces

**EXAMPLE OF PURCHASE ORDER****Standard design:**

1. Screwing cylindrical thermowell, non-reduced  
991 100033  
20 pcs
2. Nipple  
991 NVP4 M27 72  
6 pcs

**Special request:**

1. Welded cylindrical thermowell, non-reduced  
991 120029  
Nominal length L = 380 mm  
10 pcs
2. Nipple  
991 NVP4 M27 99  
material 1.5415  
6 pcs

TABLE 1 - DESIGN OF TEMPERATURE SENSORS TO THERMOWELL ČSN TYPE 341

SPECIFICATION						ORDERING NUMBER														
						341	x	x	x	x	x	x	x	x	x	/xxxxxx	/xxx			
Nominal length L [mm]	100	Length of adapter L <sub>n</sub> [mm]	150	Length of measuring insert L <sub>mv</sub> [mm]	280	1														
	160				340	2														
	250				430	3														
	400				580	4														
	630				810	5														
	Other (min. 75) *								9											
Nominal length L [mm]	100	Length of adapter L <sub>n</sub> [mm]	80	Length of measuring insert L <sub>mv</sub> [mm]	210	1														
	160				270	2														
	250				360	3														
	400				510	4														
	630				740	5														
	Other (min. 75) *								9											
Length of adapter	150 mm					1														
	80 mm	max. -200 to 250 °C				2														
	Other **)*) (min. 80 mm)					9														
Thermowell material	without thermowell						0													
Connecting thread	M20 x 1.5							2												
	G1/2								3											
Sensor head	Ball (Al alloy) (for converter Ex i with external and internal terminals)										3									
	Ball, plastic (cannot be used for converter Ex ia)											4								
	Ball head with increased lid (Al alloy) without display for converter in the lid or with display (for converter Ex i with external and internal terminals)												5							
	Small ball (Al alloy) (only for the terminal board and converters APAQ-HCF, MINIPAQ-HLP)													6						
	Other *)														9					
Tube of measuring insert [mm]	Ø 6 mm ± 0,1											1								
	Ø 8 mm (with limiting bush)												2							
	Ø 3 mm ± 0,1													3						
Thermocouple	K														K					
	J														J					
Accuracy class	1 *)															1				
	2															2				
Design of measuring ends of thermocouple pursuant to figure 5	Single thermocouple, insulated end															/JI				
	Double thermocouple, independent end															/DU				
Converter (design of thermocouple measuring ends: single thermocouple, isolated end)	Converter type		Galvanic separation	Ex ia	Range [°C]															
	Analogue linear output signal with thermoelectric voltage	APAQ-HCF			Adjustable range												/HCF			
		APAQ-HCFX		•														/HCFX		
	Programmable linear output signal with temperature	TH 200	•		Programmable range												/TH200			
		TH 200-ex	•	•													/TH200X			
		IPAQ-H	•														/IPAQH			
		IPAQ-HX	•	•													/IPAQHX			
		MINIPAQ-HLP															/MINIPAQ			
		IPAQ C330	•														/C300			
	Programmable with HART protocol linear output signal with temperature	IPAQ C330X	•	•												/C300X				
		TH 300	•													/TH300				
		TH 300-ex	•	•												/TH300X				
		MESO-H	•													/MESOH				
		MESO-HX	•	•												/MESOHX				
		248 HA NA	•													/248HANA				
Other *)	248 HA I1	•	•												/248HA11X					
	644 HA NA	•													/644HANA					
	644 HA I1	•	•								5				/644HA11X					
Without converter (for installation of the converter by the customer)																/99				
LED display LPI-01 (only with converter, with the exception of converter 644 HANA)																/00				
LED display to loop 4-20 mA	LED display Ex ia *) (only with converter Ex ia, except converter 644 HA11X)																/LDX			

**Standard design**

\*) Only as a special request after an agreement with the manufacturer

\*\*) In case of adapter length below 150 mm (minimum 80 mm), the temperature range is decreased to -200 to 250 °C

**TABLE 2 – ADDITIONAL REQUIREMENT FOR DESIGN OF TEMPERATURE SENSORS TO THERMOWELL, TYPE 331**

SPECIFICATIONS			CODE	
CALIBRATION	NUMBER OF CALIBRATION POINTS	CALIBRATION RANGE		
Calibration by TPM 3342-94, define calibration points	3	0 to 800 °C	/Q4	
	3	0 to 1100 °C	/Q42	
	Other	0 to 1100 °C	/Q9	
REQUIREMENT FOR OTHER DOCUMENTATION			USE	
EU Declaration of Conformity			for design with converter	
Copy of EU-Type Examination Certificate acc to the 2014/34/EU (ATEX)			for converter and display Ex ia	
Declaration of Conformity with purchase order 2.1 pursuant to EN 10204			/2.1	

Specify the code behind ordering number. Define calibration points for codes Q4, Q42 a Q9.

**TABLE 3 - ACCESSORIES - OVERVIEW OF DESIGNS RECOMMENDED THERMOWELLS, TYPE 991 (order separately)**

SPECIFICATION						ORDERING NUMBER								
						991	xx	x	x	x	x			
Cylindrical thermowell	PN 160	Screwing external thread M27x2	Non-reduced (ON 02 7210)			Ø9		10		0				
			Reduced			Ø9/Ø6		11		0				
		Welding Bore Ø 27 mm	Non-reduced (ON 02 7212)			Ø9		12						
			Reduced			Ø9/Ø6		13						
Conical thermowell	PN 250	Screwing external thread M33x2	For high speeds of flow non-reduced (ON 02 7215)			Bore [mm]	Ø9 only L = 160, 250 a 400 only sensors thread M20x1,5		15	0	0		2	
			For high parameters of operation liquid reduced (ON 02 7217)					Ø9/Ø6 only L = 160, 250 a 400 only sensors thread M20x1,5		17	0	0		2
			For high parameters of operation liquid reduced (ON 02 7218)						Ø9/Ø7/Ø3,2 only L = 160 only sensors thread M20x1,5		18	0	0	
Quickly responding thermowell	PN 250	Welding	For high parameters of operation liquid and speeds of flow			Ø7/Ø3,2 only L = 160, 250 a 400 only sensors thread M20x1,5 only from steal 1.4541		19		0	0	3	2	
Sensor thread	M20x1,5									0				
	G1/2 Only cylindrical thermowell								G					
Flange	without flange									0				
	with flange *) Only cylindrical welding thermowell								F					
Material of immersion part of thermowell	1.0577 **)		surface treatment	preservation with grease – oil	Maximum operation temperature [°C]	400						1		
	15 128					550				2				
	1.4541 ****)			brushed, polished		550 (650)***)				3				
	1.4571 **) ****)					500				4				
	1.4903 **)			Pursuant to material		620				5				
Other *)		Pursuant to material	Pursuant to material				9							
Nominal length L [mm]	100 Only cylindrical thermowell											1		
	160											2		
	250											3		
	400											4		
	630 Only cylindrical thermowell											5		
		Other *)	max. 3000			10x0, 11x0, 12xx, 13xx								
		max. 1200	for thermowells with code		1500 a 1700									
		max. 500			1800 a 1900									

\*) Only as a special request after an agreement with the manufacturer

\*\*) Only for conical thermowells with codes 1500 and 1700

\*\*\*) Maximum operation temperature 650°C only for thermowells with code 1700 and 1800

\*\*\*\*) Thermowells of these materials are suitable for contact with food

**TABLE 4 – ACCESSORIES - OVERVIEW OF DESIGNS RECOMMENDED NIPPLES FOR SCREW-IN THERMOWELLS, TYPE 991 (order separately)**

SPECIFICATION						ORDERING NUMBER				
						991	xxx	x	xxx	xx
Shape	Direct						NVP			
	Oblique (chamfer 45°)						NVS			
Internal thread	M27x2		PN	160				4	M27	
	M33x2			250				5	M33	
	Other *)							9		
Material	1.0308 or 1.0122		surface treatment	preservation with grease – oil	Maximum operation temperature [°C]	300 (only PN 40)			M27	13
	1.0577					400			M33	15
	15 128.5			550			M27	51		
	1.4541			550				72		
Other *)		Pursuant to material			Pursuant to material				99	



**TABLE 8 –OVERVIEW OF SEALING RINGS TYPE 991 SUPPLIED TO TEMPERATURE SENSORS**

EXTERNAL FIXING THREAD OF TEMPERATURE SENSORS	SEALING RING			
	DIMENSION [mm] Ød x ØD x t	MATERIAL	NUMBER	ORDERING NUMBER
M20 x 1,5 G1/2	21x27x2	copper thermally insulating insert	1 pcs	991 TK 21

The sealing ring is supplied to each sensor by default. The sealing ring can also be ordered separately using ordering number

**INSTALLATION AND CONNECTION**

**SENSOR INSTALLATION**

Install the sensors by screwing into the relevant thermowell screwed into the nipple on the piping (technological equipment) or welded into the piping wall. Before the installation, put on the enclosed sealing ring in advance. During the installation, torque of 70 Nm is recommended.

A proposal of securing the thermowell of the temperature sensors for nominal lengths exceeding 630 m is in figure 1; examples of installation of direct and oblique nipples are in figure 2.

With respect to maintaining metrological properties and the longest possible service life, it is not recommended to install the sensors in places with high turbulence of the medium, which is caused e.g. by a rapid transition from a small diameter of the piping to a larger one (when failing to comply with the required shape and dimensions of diffuser behind the flow meter), etc. Recommended distance of the temperature sensor from the installation flange of the flow meter is min. 1 m.

**ELECTRICAL CONNECTION**

The electrical connection may be only realized by qualified workers.

The terminal board of the sensor (converter) is accessible after tilting the lid of the head, which is connected with one screw. Connect the evaluation devices to the sensor (with converter) with a non-armoured cable with double insulation with outer diameter 5 to 8 mm, internal wires with Cu core with cross section 0.5 to 1.5 mm<sup>2</sup>.

Sensors without converter connect with compensation or thermocouple wiring with cross section 0.5 to 1.5 mm<sup>2</sup>.

Seal the cable gland adequately.

**! WARNING**

**Do not use independent wires without jacket for electrical connection. To ensure the ingress protection grade in the outlet, the connecting cable shall have circular cross-section. Temperature resistance of the cable shall comply with the ambient temperature!**

The cable insulation shall have chemical and mechanical resistance in compliance with the conditions, in which the cable will be installed. It is recommended supporting the cable along its length between the sensor and the follow-up device. In the environment with interfering signals, use shielded cable in the power supply circuit. Shielding may be only grounded (earthed) in one point. The cable should not be placed together with power cables.

In case of the sensor with HART protocol converter, the maximum length of wiring is defined by the arrangement of wires of the connecting cable. The total length of wiring may be up to 1500 m. It requires a twisted two-wire with shared shielding with the cross section of the core min. 0.5 mm<sup>2</sup>. HART communicator is connected to the supply loop of the converter pursuant to Figure 4. To achieve reliable communication, total load resistor of min. 250 Ω shall be in the circuit of the output loop.

**INSTALLATION OF THE SENSOR WITH CONVERTER Ex i IN CONDITIONS WITH EXPLOSIVE GASEOUS ATMOSPHERE**

In environment with explosive gaseous atmosphere a sensor without converter or sensor with Ex ia converter can be installed.

The installation of the sensor in the environment with explosive gaseous atmosphere shall comply with the requirements of EN 60079-14.

**The sensor without converter** (with ball head from alloy Al with external and internal terminals – only on ZP (special requirement) after an agreement with the manufacturer), can be used as a simple device pursuant to EN 60079-11 Article 5.7 in an intrinsically safe circuit Ex ia pursuant to EN 60079-25. For a simple device, the maximum temperature can be

determined from the value of the P<sub>0</sub> of the connecting device and the temperature class is determined.

**The sensor with converter Ex ia** may be used in case of compliance with the parameters Ex ia of the converter according to the enclosed converter manual.

Only insulated cables must be used in intrinsically safe circuits which is able to withstand the electrical strength test with a voltage equal to twice the voltage in the intrinsically safe circuit, or 500 V eff (DC 750 V), taking greater of the values.

In case of installation of intrinsically safe circuits, including cables, the maximum permitted inductance, capacity or ratio LiR and surface temperature may not be exceeded. Permitted values can be found out in the documentation of the follow-up equipment or label with the designation. Locate the follow-up equipment outside of the dangerous area. An intrinsically safe source must be always used that is approved for power supply of intrinsically safe equipment in the sense of EN 60079-11.

**! WARNING** Ex

**The programmable converter may not be connected to the PC or HART communicator if the converter is located in the explosive environment.**

Shielding of the cable of the intrinsically safe circuit must be grounded in the same place as the intrinsically safe circuit, the connection must be outside the dangerous area

For the installations in dangerous areas, mutual interconnection is required (bringing to the same potential). To achieve it, terminals on the sensor head can be used.

The sensor need not be connected to the system of mutual interconnection separately if it is installed firmly and has metal interconnection with the structural parts or the piping, which is connected to the system of mutual interconnection.

**SENSOR HEAD WITH CLAMPS**

for the sensor with converter Ex i

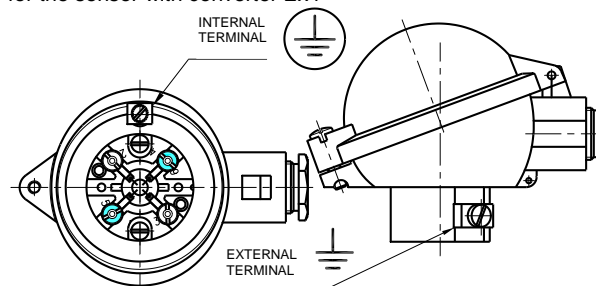

**Maximum cross-section of wire for connection to external and internal terminals:**

Internal terminal: stranded wire 1.5 mm<sup>2</sup>, full wire 2.5 mm<sup>2</sup>

External terminal: stranded wire 4.0 mm<sup>2</sup>, full wire 6.0 mm<sup>2</sup>

If stranded wires are used for the interconnection, they shall be protected against fraying with pressing hollow.

**COMMISSIONING**

After the sensor installation, including closing the fixed closure, and connection of the follow-up (evaluation) device to the supply voltage (and the settlement period of the converter), the equipment is prepared for operation.

**! WARNING** Ex

**After finish installation of the sensor in the environment with explosive gaseous atmosphere the default device revision and installation must be performed in EN 60079-17.**

**OPERATION AND MAINTENANCE**

The sensor does not require any operation and maintenance.

For the sensor in the environment with explosive gaseous atmosphere maintenance and following regular periodic revisions or continuous supervision of professional personnel are carried out compliance with EN 60079-17.

**SENSOR UNINSTALLATION**

Disconnect the sensor from the supply source.  
 The terminal board of the sensor (converter) is accessible after tilting of the lid of the head that is connected with one screw.  
 Measuring insert of the sensor can be replaced and is uninstalled from the head after disconnecting the cable by releasing two screws.  
 If the sensor is connected to the system of interconnection, it is necessary to release the wire for mutual interconnection from the terminal on the head of the sensor before the total uninstillation of the sensor.  
 Screw the sensor from the thermowell; torque is approx. 70 Nm. While releasing the screw union of the sensor, the thermowell may never be released.

**SPARE PARTS**

Spare parts shall be delivered by the manufacturer.  
 Relevant measuring inserts can be ordered pursuant to the following table:

SPECIFICATION		ORDERING NUMBER					
		MV340	/xxx/	x	x	x	/xxx
Length of measuring insert [mm]			Pursuant to tab. 1				
Tube of measuring insert [mm]	∅ 6			1			
	∅ 8 (with limiting bush)			2			
	∅ 3			3			
Sensing probe	thermocouple K				K		
	thermocouple J				J		
Accuracy class	1					1	
	2					2	
Connection of terminal board and design of measuring ends of thermocouple or converter	Single thermocouple insulated end						/JI
	Double thermocouple independent end						/DU
Converter pursuant to tab. 1							converter

**EXAMPLE OF PURCHASE ORDER OF MEASURING INSERT**

Thermoelectric measuring insert without converter  
 340 /430/ 1K2/JI  
 6 pcs

To order the certified measuring inserts, specify the code according to Table 2 – Additional requirements – behind the ordering number.

The measuring inserts are marked according to Article DESIGNATION. Designation is completed with the ordering number.

Each delivery includes

- Delivery note
- Measuring insert pursuant to the purchase order
- Optional accessories to the measuring insert with a programmable converter
  - o Configuration program according to the required converter
  - o Communication modem (for serial port RS 232C) according to the required converter
- Accompanying technical documentation in Czech
  - o Product manual
  - o Product quality and completeness certificate, which also serves as the warranty certificate
  - o EU Declaration of Conformity (for design with converter Ex ia)

If it is established in the purchase contract or agreed otherwise, the following documentation can be also delivered with the product

- Calibration sheet (for calibrated design)
- EU Declaration of Conformity (for design with converter)
- Copy of EU-Type Examination Certificate pursuant to the Directive No 2014/34/EU for design with converter Ex ia

**REPAIRS**

The sensors shall be repaired by the manufacturer. They shall be sent for repair in the original or equal package without accessories.

**WARRANTY**

The warranty period is 24 months from the receiving of the product by the customer, unless established otherwise in the contract. Rejection of defects shall be enforced in writing at the manufacturer within the warranty period. The rejecting side shall identify the product name, ordering and manufacturing numbers, date of issue and number of the delivery note, clear description of the occurring defect and the subject of the claim. If the rejecting side is invited to send the device for repair, it shall do so in the original package of the manufacturer and/or in another package ensuring safe transport.  
 The warranty shall not apply to defects caused by unauthorized intervention into the device, its forced mechanical damage or failure to comply with operation conditions of the product and the product manual.

**DISABLING AND LIQUIDATION**

The product and its package do not include any parts that could impact the environment.  
 The products that are withdrawn from operation (including their packages, with the exception of products marked as electrical equipment for the purposes of return withdrawal and separate salvage of electrical waste), may be disposed of to sorted or unsorted waste pursuant to the type of waste.  
 The manufacturer realizes free return withdrawal of marked electrical equipment (from 13.8.2005) from the consumer and points out the danger connected with their illegal disposal. The package of the sensor can be recycled completely. Metal parts of the products are recycled, non-recyclable plastic materials and electrical waste shall be disposed of in accordance with applicable legislation.

**FIGURE 1 - PROPOSAL OF SECURING THERMOWELL OF TEMPERATURE SENSORS**

(for nominal lengths exceeding 630 mm)  
 Prescribed thermowells of type 991 (pursuant to ON 02 7210, ON 02 7212, ON 02 7215 or ON 02 7217) shall be used

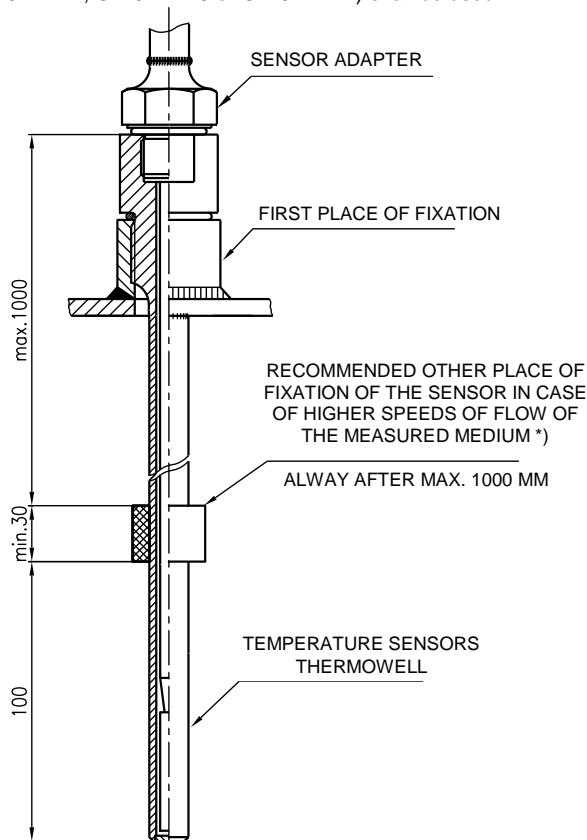

\*) In case of flow of the measured medium, the thermowells are stressed with dynamic effects of the flowing medium and this stress depends on the speed of flow, physical properties of the measured medium and immersion length of the thermowell.  
 If the occurrence of such dynamic effects can be expected, it is recommended to realize further fixation of the sensor thermowell pursuant to the above mentioned proposal.

FIGURE 2 - EXAMPLES OF INSTALLATION OF DIRECT AND OBLIQUE NIPPLES PURSUANT TO EN 1434-2

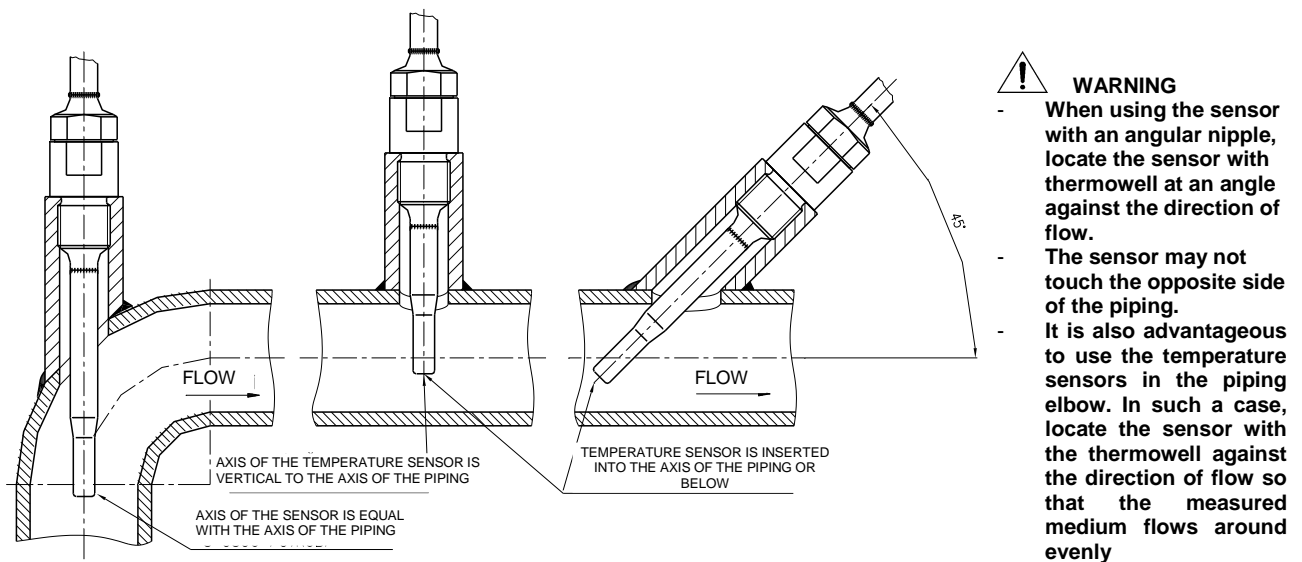
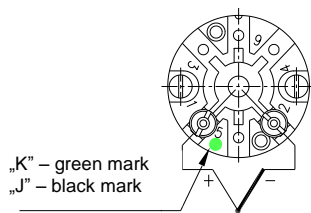

FIGURE 3 - SCHEME OF CONNECTION OF TEMPERATURE SENSORS

SCHEME OF CONNECTION WITHOUT CONVERTER

with single thermocouple



with double thermocouple

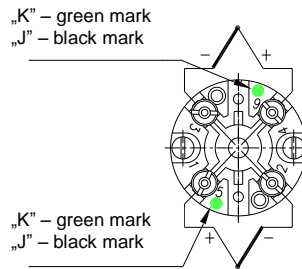

SCHEME OF CONNECTION WITH CONVERTER AND DISPLAY

with converter

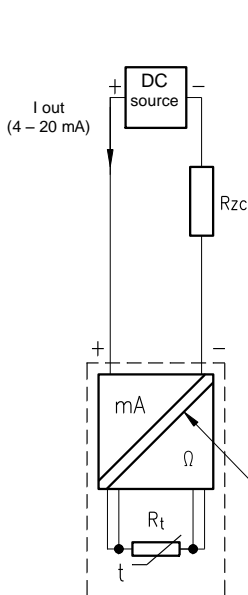

with converter with HART protocol

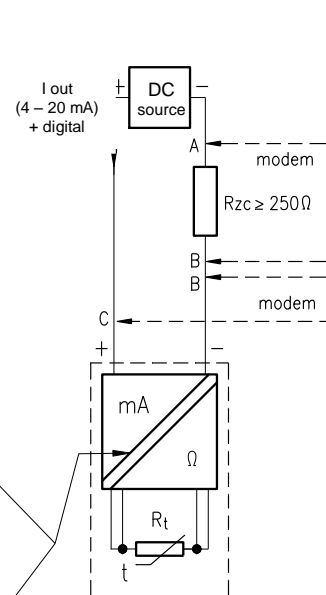

with converter Ex ia

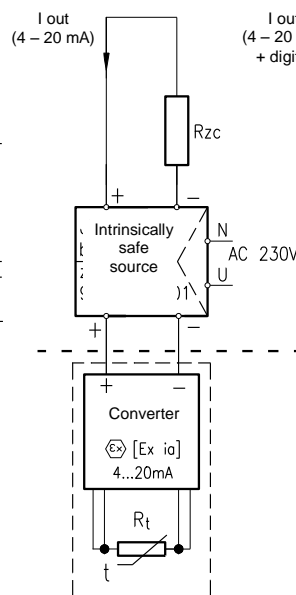

with converter Ex ia with HART protocol

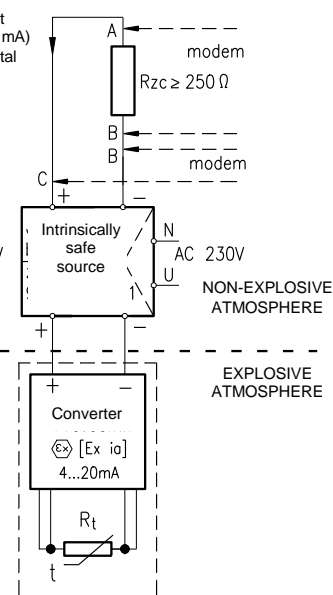

Galvanic separation pursuant to the converter

A-B and B-C options of connection of the control unit (HART modem, HART communicator)

Rzc = total load resistor



**FIGURE 4 - EXAMPLE OF OPERATION CONNECTION OF TEMPERATURE SENSOR WITH CONVERTER IN LOOP 4 - 20 mA**

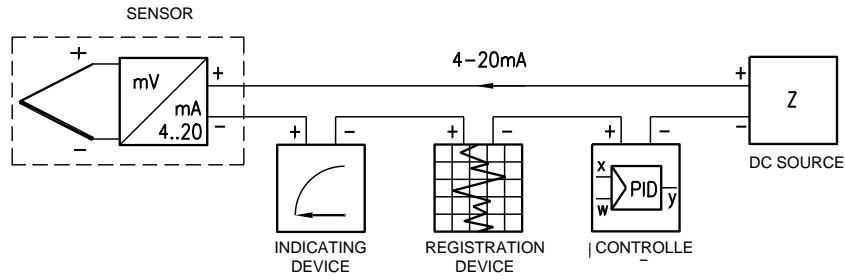

**FIGURE 5 - DESIGN OF MEASURING ENDS OF JACKETED THERMOCOUPLES (SCHEMATIC ILLUSTRATION)**

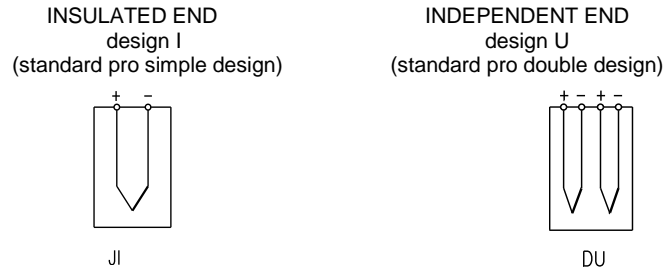

June 2018  
 © ZPA Nová Paka, a.s.



Notified Person No  
 by Type of Converter