



PRODUCT MANUAL

Thermoelectric temperature sensor to heat sink DIN without converter or with converter type series 330 type 331

FOR DESIGN WITH CONVERTER A MANUAL IS ENCLOSED TO THE RELEVANT CONVERTER

APPLICATION

- For exact remote measurement of temperature of steady and running liquids (gases and fluids), for which the properties of the heat sink of the sensor selected by the customer are suitable; the measurement may be realized up to the temperature and pressure determined by heat sink resistance
- For explosive conditions in areas Zone 2, Zone 1 and Zone 0 pursuant to ČSN EN 60079-10 in case of using the converter Ex ia or in case of connection to the Ex ia circuit
- In a set with control or diagnostic systems for process monitoring
- In design with converter to convert signal of the thermoelectric sensor to unified output signal 4 to 20 mA or digital signal (converter with HART protocol)

The sensors with converter are rated products pursuant to the Act No. 22/1997 Coll. and Declaration of Conformity **EC-331000** is issued for them.

DESCRIPTION

The sensor consists of a replaceable measuring insert with flange and ceramic terminal board or installed two-wire converter (insulated or non-insulated, even in design Ex i) and protective armature, consisting of the head and adapter with screw joint for the connection of the sensor into the heat sink selected by the customer. The head is provided with a lid and cable outlet for the connection wiring.

The terminal board of the sensor (converter) is accessible after tilting away the lid of the head, which is connected with one screw. The sensor with converter in design Ex ia is provided on its head with both external and internal terminals for the connection of the grounding wire or wire for mutual interconnection. The converter is installed either directly on the flange of the measuring insert or in the lid of the head.

The sensor with converter is supplied from an external source. The installed converter is set-up to the required range at the sensor manufacturer.

To measure temperature, a defined change of thermoelectric voltage of the sensor in dependence on the change of temperature of the measured environment is used.

TECHNICAL DATA

The sensor design corresponds to DIN 43772. The sensor is designed pursuant to ČSN EN 61140 ed.2 as an electrical equipment of protection class III for the application in networks with the category of overvoltage in the installation II and pollution grade 2 pursuant to ČSN EN 61010-1, the follow-up (evaluation) device shall comply with Article 6.3 thereof.

Measuring range:

Sensor with standard adapter $L_n = 150$ (140) mm
for thermocouple of type "J" -200 to 800 °C
for thermocouple of type "K" -200 to 1150 °C

Sensor with shortened adapter $L_n \text{ min} = 80$ mm
for thermocouple of type "J" and "K" -200 to 250 °C

The upper limit of the measurement range is limited by resistance of the material of the applied heat sink.

Measuring range of the sensor with converter is given by the range of the selected converter.

Electric strength pursuant to ČSN EN 61010-1, Article 6.8.4:
500 V eff

(only measuring insert without converter or design with insulated converter)

Electric insulation resistance pursuant to ČSN EN 61515:
min. 1000 M Ω , at ambient temperature 20±15°C and
max. 80% relative humidity

Power supply of converter:

DC 24 V from source SELV, e.g. INAP 16 and INAP 901

Other data of converter: refer to enclosed manual
Ingress protection pursuant to ČSN EN 60529: IP65

Operation position:

discretionary; the outlet shall not be situated upwards

Type of operation:

continuous

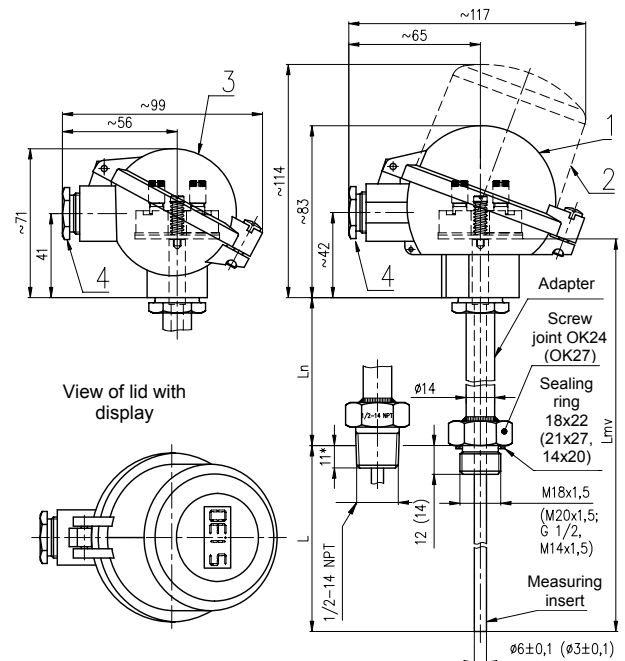

- 1 - Ball head (Al alloy)
(for converter Ex i with both external and internal terminals)
or plastic ball head
(it cannot be used for converter Ex i)
 - 2 - Ball head with increased lid (Al alloy)
without display for converter in lid or with display
(for converter Ex i with both external and internal terminals)
 - 3 - Small ball head (Al alloy)
(only for terminal board)
 - 4 - Cable outlet M20x1.5
- L Nominal length
 L_n Length of adapter
 L_{mv} Length of measuring insert
11* Standard length of screwing in

Sensor weight:

With ball head (Al alloy), adapter 150 mm and
nominal length

200 mm approx. 0.6 kg

Applied materials:

Stem tube of measuring insert

for thermocouple of type "J" steel 1.4541
for thermocouple of type "K" INCONEL 600

Adapter

steel 1.4541

Head

aluminium alloy painted with polyester
paint or plastic PPO (phenyl polyoxide)

Sealing of lid of head

oil-resistant rubber

Head terminals of terminal board

brass with Ni surface

Connecting items of sensor

stainless steel

OPERATION CONDITIONS

The environment is defined by the group of parameters and their severity grades IE 36 pursuant to ČSN EN 60721-3-3 and the following operation conditions.

Ambient temperature for sensor head and outlet:

- For design without converter -50 °C to 120 °C
- For design with converter pursuant to type of converter (refer to enclosed converter manual)
- For design with converter and display -20 °C to 70 °C

Vibrations:

| Sensor | with converter | | without converter | |
|--|----------------|----------|-------------------|----------|
| | 110, 140, 170 | 200, 260 | 110, 140, 170 | 200, 260 |
| Nominal length L [mm] | 110, 140, 170 | 200, 260 | 110, 140, 170 | 200, 260 |
| Frequency range [Hz] | 10 to 500 | | | |
| Drift amplitude [mm] | 0.2 | 0.15 | 0.5 | 0.2 |
| Acceleration amplitude [ms ⁻²] | 29.4 | 19.6 | 68.7 | 39.2 |

Relative ambient humidity:

10 to 100 % with condensation, with upper limit of water content 29 g H₂O/kg of dry air

Atmospheric pressure: 70 to 106 kPa**Maximum speed of flow of liquids:**

pursuant to parameters of the heat sink used by the customer

Resistance of material of PPO (phenyl polyoxide) head:

| | |
|---------------------------|---------------------|
| Kerosene | partially resistant |
| Diesel oil | resistant |
| Benzene | partially resistant |
| Animal and vegetable oils | resistant |
| Weak hydroxides | |
| Strong hydroxides | |
| Weak acids | |
| Strong acids | |
| Sea water | partially resistant |
| Trichloroethylene | |

Resistance of material of lid sealing (oil-sealing rubber):

| | |
|---------------------------|---------------------|
| Alcohol | resistant |
| Ether | |
| Benzol | |
| Petrol | |
| Ester | |
| Animal and vegetable oils | |
| Mineral oil | |
| Engine oil | |
| Weak alkali hydroxides | |
| Strong alkali hydroxides | |
| Weak acids | resistant |
| Strong acids | non-resistant |
| Sea water | resistant |
| Trichloroethylene | partially resistant |
| Hot water | |

METROLOGICAL DATA

Sensing probe: measuring thermocouple J (Fe-CuNi) or K (NiCr-NiAl) pursuant to ČSN EN 60584-1, Ø 6 or Ø 3 mm, tolerance class 2 or 1 pursuant to ČSN IEC 584-2

single or double with insulated measuring connection

Output signal of

analogue converter (linear with thermoelectric voltage):
4 to 20 mA

programmable converter (linear with measured temperature):
4 to 20 mA (+ digital for HART protocol)

Calibration depth of immersion of the measuring insert of the sensor

for temperature points within the range from -70 to 250°C:
200 mm (min. 160 mm)

for temperature points over 250°C:
300 mm (min. 260 mm)

The distance of the flange of the measuring insert from the medium level in the calibration bath shall be at least 40 mm at temperatures up to 250°C and min. 70 mm at temperatures over 250°C.

Temperature response time pursuant to ČSN IEC 751 in whirling water (characteristic value):

Without heat sink (independent meas. insert) 0.5 5.5 s

With heat sinks pursuant to DIN 43772, shape 4 (L = 100, 140))

0.5 85 s
0.9 250 s

With heat sinks pursuant to DIN 43772, shape 4 (L = 200, 260))

0.5 53 s
0.9 115 s

DESIGNATION :**Data on head label**

- Trademark of the manufacturer
- Made in Czech Republic
- Type of thermoelectric sensor / tolerance class
- Measuring range or pre-set converter range
- Product ordering number
- Ingress protection
- Manufacturing number
- Output signal 4 to 20 mA (design with converter)
- Ambient temperature
- Designation of non-explosiveness and EC-Type Examination Certificate number (for design with converter Ex i)
- CE mark with identification number of the notified person (for design with converter Ex i)

Data on measuring insert label

- Trademark
- Type of sensor
- Manufacturing number

Data on converter label

- Type of sensor
- Pre-set temperature range

DELIVERY

Unless agreed otherwise with the customer, each delivery includes

- Delivery note
- Sensor pursuant to the purchase order
- Sealing ring
 - o Cu 18x22x1.5 (ČSN 02 9310.2) for connecting thread M18x1.5,
 - o 21x27 TPD 62-014-91 for connecting thread M20x1.5 a G ½
 - o 14x20 TPD 62-0114-91 for connecting thread M14x1.5 (for thread 1/2-14NPT, the sealing ring is not delivered)
- Suitable heat sinks and weld-on pieces ordered separately pursuant to the catalogue of accessories, type 991
- Optional accessories to the sensor with programmable converter
 - o Configuration (parameterization) programme pursuant to the required converter
 - o Communication modem (for serial port RS 232C) pursuant to the required converter
- Accompanying technical documentation in Czech
 - o Product quality and completeness certificate, which also serves as the warranty certificate
 - o EC Declaration of Conformity for design with converter Ex i
 - o Calibration sheet (for uncertified calibrated design)
 - o Product manual

If it is established in the purchase contract or agreed otherwise, the following documentation can be also delivered with the product

- Copy of the Inspection Certificate 3.1 for material of stem tube and heat sink with the casting number
- Copy of EC-Type Examination Certificate pursuant to the Decree of the Government 23/2003 Coll. for design with converter Ex i

ORDERING TEMPERATURE SENSORS

The purchase order shall specify

- Name
- Product ordering number
- Measuring range
- If calibration is required and in what temperature points
- If the delivery of heat sink and weld-on piece pursuant to the type 991 is required for the sensor as accessories
- If optional accessories to the sensor with programmable converter is required
- Other (special) requirements
- Number of pieces

Behind the ordering number specified pursuant to Table 1, the customer shall identify the required range of measured temperature (i.e. so-called lower and upper temperature limits in °C) and, as the case may be, other non-standard required parameters for converter configuration (e.g. indication of sensor tripping, dampening, required designation - tagging etc.).

EXAMPLE OF PURCHASE ORDER

Standard design:

Thermoelectric temperature sensor to heat sink DIN

Without converter
331 410 131 K2/JI
Range -200 to 1150°C
6 pcs

Special requirement:

Thermoelectric temperature sensor to heat sink DIN
With converter
331 910 231 J2/HCF
Nominal length L 380 mm
Range 0 to 300°C
6 pcs

TABLE 1 - DESIGN OF TEMPERATURE SENSORS TO HEAT SINK DIN TYPE 331

| SPECIFICATIONS | | | | | ORDERING NUMBER | | | | | | | | | | | | | | | | | | | |
|---|---|---------------------------------------|-----|---|-----------------|---|-----|---|---|---|---|---|---|---------|------|--|--|--|-----------|-----------|-----|--|--|--|
| | | | | | 331 | x | x | 0 | x | x | 1 | x | x | /xxxxxx | /xxx | | | | | | | | | |
| Nominal length L [mm] | 110 | Length of adapter L _n [mm] | 140 | Length of measuring insert L _{mv} [mm] | 275 | 1 | | | | | | | | | | | | | | | | | | |
| | 140 | | 150 | | 315 | 2 | | | | | | | | | | | | | | | | | | |
| | 170 | | 140 | | 335 | 3 | | | | | | | | | | | | | | | | | | |
| | 200 | | 150 | | | | 375 | 4 | | | | | | | | | | | | | | | | |
| | 260 | | | | | | 435 | 5 | | | | | | | | | | | | | | | | |
| | 410 | | | | | | 585 | 6 | | | | | | | | | | | | | | | | |
| | Other (min. 75 *) | | | | | | | | 9 | | | | | | | | | | | | | | | |
| Nominal length L [mm] | 110 | Length of adapter L _n [mm] | 80 | Length of measuring insert L _{mv} [mm] | 215 | 1 | | | | | | | | | | | | | | | | | | |
| | 140 | | | | 245 | 2 | | | | | | | | | | | | | | | | | | |
| | 170 | | | | 275 | 3 | | | | | | | | | | | | | | | | | | |
| | 200 | | | | 305 | 4 | | | | | | | | | | | | | | | | | | |
| | 260 | | | | 365 | 5 | | | | | | | | | | | | | | | | | | |
| | 410 | | | | 515 | 6 | | | | | | | | | | | | | | | | | | |
| | Other (min. 75 *) | | | | | | | 9 | | | | | | | | | | | | | | | | |
| Length of adapter | 150 mm (140 mm) | | | | | | | | | | | | | | | | | | | | | | | |
| | 80 mm | max. -200 to 250 °C | | | | | | | | | | | | | | | | | | | | | | |
| | Other **) | (min. 80 mm) | | | | | | | | | | | | | | | | | | | | | | |
| Connecting thread / diameter of measuring insert | M18 x 1.5 / Ø 6mm | | | | | | | | | | | | | | | | | | | | | | | |
| | M20 x 1.5 / Ø 6mm | | | | | | | | | | | | | | | | | | | | | | | |
| | G1/2 / Ø 6mm | | | | | | | | | | | | | | | | | | | | | | | |
| | M14 x 1.5 / Ø 3mm *) | | | | | | | | | | | | | | | | | | | | | | | |
| | 1/2-14NPT / Ø 6mm | | | | | | | | | | | | | | | | | | | | | | | |
| Sensor head | Ball (Al alloy) (for converter Ex i with both external and internal terminals) | | | | | | | | | | | | | | | | | | | | | | | |
| | Ball, plastic (cannot be used for converter Ex i) | | | | | | | | | | | | | | | | | | | | | | | |
| | Ball head with increased lid (Al alloy) without display for converter in lid or with display (for converter Ex i with both external and internal terminals) | | | | | | | | | | | | | | | | | | | | | | | |
| | Ball, small (Al alloy) (only for terminal board and converters APAQ-HCF, MINIPAQ-HLP) | | | | | | | | | | | | | | | | | | | | | | | |
| | Other *) | | | | | | | | | | | | | | | | | | | | | | | |
| Thermocouple | K | | | | | | | | | | | | | | | | | | | | | | | |
| | J | | | | | | | | | | | | | | | | | | | | | | | |
| Accuracy class | 1 *) | | | | | | | | | | | | | | | | | | | | | | | |
| | 2 | | | | | | | | | | | | | | | | | | | | | | | |
| Design of measuring ends of thermocouple pursuant to Figure 3 | Single thermocouple, insulated end | | | | | | | | | | | | | | | | | | | | | | | |
| | Double thermocouple, independent end | | | | | | | | | | | | | | | | | | | | | | | |
| Converter type | | Galvanic separation | Ex | Range [°C] | | | | | | | | | | | | | | | | | | | | |
| Analogue linear output signal with thermoelectric voltage | APAQ-HCF | | | Adjustable range | | | | | | | | | | | | | | | /HCF | | | | | |
| | APAQ-HCFX | | • | | | | | | | | | | | | | | | | | /HCFX | | | | |
| Programmable linear output signal with temperature | TH 200 | • | | Programmable range | | | | | | | | | | | | | | | | /TH200 | | | | |
| | TH 200-ex | • | • | | | | | | | | | | | | | | | | | /TH200X | | | | |
| | IPAQ-H | • | | | | | | | | | | | | | | | | | | /IPAQH | | | | |
| | IPAQ-HX | • | • | | | | | | | | | | | | | | | | | /IPAQHx | | | | |
| Programmable with HART protocol linear output signal with temperature | MINIPAQ-HLP | | | | | | | | | | | | | | | | | | | /MINIPAQ | | | | |
| | TH 300 | • | | | | | | | | | | | | | | | | | | /TH300 | | | | |
| | TH 300-ex | • | • | | | | | | | | | | | | | | | | | /TH300X | | | | |
| | MESO-H | • | | | | | | | | | | | | | | | | | | /MESOH | | | | |
| | MESO-HX | • | • | | | | | | | | | | | | | | | | | /MESOHx | | | | |
| | 248 HA NA | • | | | | | | | | | | | | | | | | | | /248HANA | | | | |
| 248 HA I1 | • | • | | | | | | | | | | | | | | | | | /248HAI1X | | | | | |
| 644 HA NA | • | | | | | | | | | | | | | | | | | | /644HANA | | | | | |
| 644 HA I1 | • | • | | | | | | | | | | | | | | | | | | /644HAI1X | | | | |
| Other *) | | | | | | | | | | | | | | | | | | | | /99 | | | | |
| Without converter (for converter installation by the customer) | | | | | | | | | | | | | | | | | | | | /00 | | | | |
| LED display to loop 4-20 mA (only with converter, with the exception of converter 644 HA) | | | | | | | | | | | | | | | | | | | | | | | | |
| LED display | | | | | | | | | | | | | | | | | | | | | /LD | | | |

Standard design

*) Only as a special requirement after an agreement with the manufacturer

**) In case of adapter length below 140 mm (minimum 80 mm), the temperature range is decreased to -200 to 250 °C

ORDERING HEAT SINKS

The purchase order shall specify:

- Name
- Ordering number of heat sink
- Number of pieces

EXAMPLE OF PURCHASE ORDER

Standard design:

Welding heat sink pursuant to DIN shape 4
991 DIN 407244 20 pcs

ORDERING WELD-ON PIECES

The purchase order shall specify

- Name
- Ordering number of weld-on piece
- Number of pieces

ORDERING NUMBERS OF WELD-ON PIECES, TYPE 99 1

- Weld-on piece - 991 NVD4 D24 51 (material 15 128.5)
- 991 NVD4 D26 51 (material 15 128.5)
- 991 NVD4 D24 72 (material 1.4541)
- 991 NVD4 D26 72 (material 1.4541)

TABLE 2 - OVERVIEW OF DESIGNS AND ORDERING WELDING HEAT SINKS PURSUANT TO DIN, SHAPE 4 (4F)

| SPECIFICATIONS | | | | | | ORDERING NUMBER | | | | | | | | | |
|--|----------------------------|---|-----------------------------------|---------|-------------------------------|-----------------|-----|---|---|---|---|---|---|--|--|
| | | | | | | 991 | DIN | x | x | x | x | x | x | | |
| Heat sink with cone pursuant to type 991 | Welding | Heat sink shape 4 pursuant to DIN 43772 | Without flange PN 250 | | | | | 4 | 0 | | | | | | |
| | | | With flange **) | | | | | 4 | F | | | | | | |
| | | Inner bore [mm] | | | | | | | | 7 | | | | | |
| | | Inner bore / outer Ø of heat sink | | | M18×1.5/ Ø 24 | | | | | | | 2 | | | |
| | | | M20×1.5/ Ø 26 | | | | | | | 3 | | | | | |
| | | | G 1/2/Ø 26 | | | | | | | 4 | | | | | |
| Nominal length of heat sink L [mm] | 110 | L1 [mm] | 65 | L2 [mm] | 105 | | | | | | | 1 | | | |
| | 140 | | 65 | | 140 | | | | | | | 2 | | | |
| | 170 | | 133 | | 170 | | | | | | | | 3 | | |
| | 200 | | 65 | | 200 | | | | | | | | 4 | | |
| | 200 | | 125 | | 200 | | | | | | | | 5 | | |
| | 260 | | 125 | | 260 | | | | | | | | 6 | | |
| | 410 | | 275 | | 410 | | | | | | | | 7 | | |
| | Other (max. 410) *) | | | | | | | | | | | | 9 | | |
| | Material of heat sink ***) | | 1.7335 *) | | Maximum operation temperature | 550 °C | | | | | | | | | |
| 1.7380 | | 580 °C | | | | | | | | | | | 2 | | |
| 1.4541 | | 580 °C | | | | | | | | | | | 3 | | |
| 1.4571 | | 400 °C | | | | | | | | | | | 4 | | |
| Other *) | | | Pursuant to material of heat sink | | | | | | | | | 9 | | | |

*) Upon a special requirement after an agreement with the manufacturer
 **) Flange design (shape, PN, DN and material) pursuant to the requirement of the customer
 ***) Surface treatment of heat sinks from material 1.7335 and 1.7380: preservation with grease - oil

PACKING

Both sensors and accessories are delivered in a packing ensuring resistance to the impact of thermal effects and mechanical effects pursuant to controlled packing regulations.

TRANSPORT

The sensors may be transported on conditions corresponding to the set of combinations of classes IE 21 pursuant to ČSN EN 60721-3-2 (i.e. by airplanes and trucks, in premises that are ventilated and protected against atmospheric conditions).

STORAGE

The sensors may be stored on conditions corresponding to the set of combinations of classes IE 12 pursuant to ČSN EN 60721-3-1 but with ambient temperature between -20 and 70 °C (i.e. in places where temperature and humidity are not controlled, with a threat of condensation, dripping water and formation of ice, without a special threat of an attack with biological agents, with vibrations of small significance and not situated close to sources of dust and sand.)

CERTIFICATION

- Non-explosiveness Ex i, EC-Type Examination Certificate pursuant to the Decree of the Government 23/2003 Coll., (pursuant to the type of the converter)

RELIABILITY

Indicators of reliability in operation conditions and ambient conditions specified herein

- Medium time of operation between failures 96 000 hours (inf. value)

Expected service life 10 years

CALIBRATION

It is realized pursuant to TPM 3342-94 and in compliance with ČSN EN 60584-1 and ČSN IEC 584-2, usually in three temperature points spread evenly within the operation range of the sensor or in the points according to the requirement of the customer. Calibration sheets with measured data are issued for calibrated sensors.

INSTALLATION AND CONNECTION

SENSOR INSTALLATION

Install the sensors by screwing into the relevant heat sink screwed into the weld-on piece on the piping (technological equipment) or welded into the piping wall. Before the installation, put on the enclosed sealing ring in advance (for thread 1/2-14NPT, the sealing ring is not used). During the installation, torque of 70 Nm is recommended; for thread 1/2-14NPT it is 40 Nm.

With respect to maintaining metrological properties and the longest possible service life, it is not recommended to install the sensors in places with high turbulence of the medium, which is caused e.g. by a rapid transition from a small diameter of the piping to a larger one (when failing to comply with the required shape and dimensions of diffuser behind the flow meter), etc. Recommended distance of the temperature sensor from the installation flange of the flow meter is min. 1 m.

EXAMPLES OF INSTALLATION OF HEAT SINKS DIN

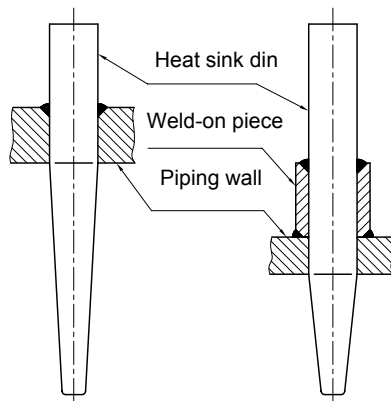

ELECTRICAL CONNECTION

The electrical connection may be only realized by qualified workers pursuant to § 5 of the Decree 50/1978 Coll.

The terminal board of the sensor (converter) is accessible after tilting away the lid of the head, which is connected with one screw.

Connect the evaluation devices to the sensor with a non-armoured cable with double insulation with outer diameter 5 to 8 mm, internal wires with Cu core (sensor with converter) or compensation wiring (sensor without converter) with cross section 0.5 to 1.5 mm². Seal the cable outlet adequately.



WARNING

Do not use independent wires without jacket for electrical connection. To ensure the Ingress Protection grade in the outlet, the connecting cable shall have circular cross-section. Temperature resistance of the cable shall comply with the ambient temperature!

The cable insulation shall have chemical and mechanical resistances in compliance with the conditions, in which the cable will be installed. It is recommended supporting the cable along its length between the sensor and the follow-up device. In the environment with interfering signals, use shielded cable in the power supply circuit. Shielding may be only grounded (earthed) in one point. The cable should not be placed together with power cables.

In case of the sensor with HART protocol converter, the maximum length of wiring is defined by the arrangement of wires of the connecting cable. The total length of wiring may be up to 1500 m. It requires a twisted two-wire with shared shielding with the diameter of the cross section min. 0.5 mm². The HART communicator is connected to the supply loop of the sensor with converter pursuant to Figure 2.

To achieve reliable communication, the total load resistance of min. 250 shall be in the circuit of the output loop.

INSTALLATION OF THE SENSOR WITH CONVERTER Ex i IN ENVIRONMENT WITH EXPLOSIVE GASEOUS ATMOSPHERE

The installation of the sensor in the environment with explosive gaseous atmosphere shall comply with the requirements of CSN EN 60079-14 ed. 2.



WARNING



Ex i parameters shall be complied with pursuant to the enclosed converter manual.

To ensure safety, an intrinsically safe source shall be always used pursuant to the converter manual, e.g. INAP 901 ordering number 901 000 101.

Surface temperature of the converter may not exceed the maximum surface temperature for that particular temperature class.

The programmable converter may not be connected to the PC or HART communicator if the converter is located in the explosive environment.

For the installations in dangerous areas, mutual interconnection is required (bringing to the same potential). To achieve it, terminals on the sensor head can be used.

The sensor need not be connected to the system of mutual interconnection separately if it is installed firmly and has metal

interconnection with the structural parts or the piping, which is connected to the system of mutual interconnection.

HEAD OF THE SENSOR WITH TERMINALS

(for sensor with converter Ex i)

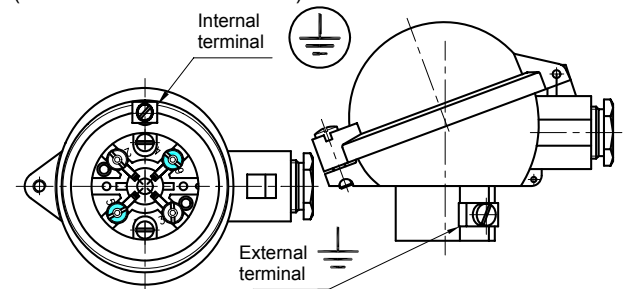

Maximum cross-section of wire for connection to external and internal terminals:

Internal terminal: stranded wire 1.5 mm², full wire 2.5 mm²

External terminal: stranded wire 4.0 mm², full wire 6.0 mm²

If stranded wires are used for the interconnection, they shall be protected against fraying with pressing hollow.

COMMISSIONING

After the installation of the sensor, including closing the fixed closure and connection of the follow-up (evaluation) device to the supply voltage (and the settlement period of the converter), the equipment is prepared for operation.

OPERATION AND MAINTENANCE

The sensor does not require any operation and maintenance.

SENSOR UNINSTALLATION

Disconnect the sensor from the power supply source.

The terminal board of the sensor (converter) is accessible after tilting away the lid of the head, which is connected with one screw.

The measuring insert of the sensor is replaceable and is uninstalled from the head after disconnecting the cable by releasing two screws.

If the sensor is connected to the system of interconnection, the wire for mutual interconnection shall be released from the terminal on the head of the sensor before the complete uninstallation of the sensor.

Unscrew the sensor from the heat sink, torque for releasing is approx. 70 Nm. When releasing the screw joint of the sensor, the heat sink may never be released.

SPARE PARTS

Spare parts shall be delivered by the manufacturer.

Relevant measuring inserts can be ordered pursuant to the following table:

| SPECIFICATIONS | | ORDERING NUMBER | | | | | |
|--|-------------------------------------|-----------------|-----------|---|---|---|-------------------------------------|
| | | MV33 0 | /xx x/ | 1 | x | x | /xxxx |
| Length of measuring insert [mm] | | | | | | | Pur sua nt to tab. 1 |
| | | | | 1 | | | |
| Sensing prob | Thermocouple K | | | | | | K |
| | Thermocouple J | | | | | | J |
| Accuracy class | 1 | | | | | | 1 |
| | 2 | | | | | | 2 |
| Connection of the terminal board and design of measuring ends of thermocouple or converter | Single thermocouple insulated end | | | | | | /JI |
| | Double thermocouple independent end | | | | | | /DU |
| | Converter pursuant to tab. 1 | | | | | | /converter |

EXAMPLE OF PURCHASE ORDER OF MEASURING INSERT

Thermoelectric measuring insert without converter
 330 /375/ 1K2/JI
 6 pcs

WARRANTY

Pursuant to Section 429 of the Commercial Code and the provisions of Section 620 (2) of the Civil Code, the manufacturer warrants for technical and operation parameters of the product specified in the manual. The warranty period is 24 months from the receiving of the product by the customer, unless established otherwise in the contract. Rejection of defects shall be enforced in writing at the manufacturer within the warranty period. The rejecting side shall identify the product name, ordering and manufacturing numbers, date of issue and number of the delivery note, clear description of the occurring defect and the subject of the claim. If the rejecting side is invited to send the device for repair, it shall do so in the original package of the manufacturer and/or in another package ensuring safe transport.

The warranty shall not apply to defects caused by unauthorized intervention into the device, its forced mechanical damage or failure to comply with operation conditions of the product and the product manual.

REPAIRS

The sensors shall be repaired by the manufacturer. They shall be sent for repair in the original or equal package without accessories.

DISABLING AND LIQUIDATION

They shall be realized in compliance with the Waste Act No. 106/2005 Coll.

The product and its package do not include any parts that could impact the environment.

Products that are withdrawn from operation, including their packages (with the exception of products marked as electrical equipment for the purposes of return withdrawal and separate salvage of electrical waste), may be disposed of to sorted or unsorted waste pursuant to the type of waste.

The manufacturer realizes free return withdrawal of marked electrical equipment (from 13.8.2005) from the consumer and points out the danger connected with their illegal disposal. The package of the sensor can be recycled completely. Metal parts of the products are recycled, non-recyclable plastic materials and electrical waste shall be disposed of in compliance with the aforesaid Act.

FIGURE 1 - SCHEME OF CONNECTION OF TEMPERATURE SENSORS

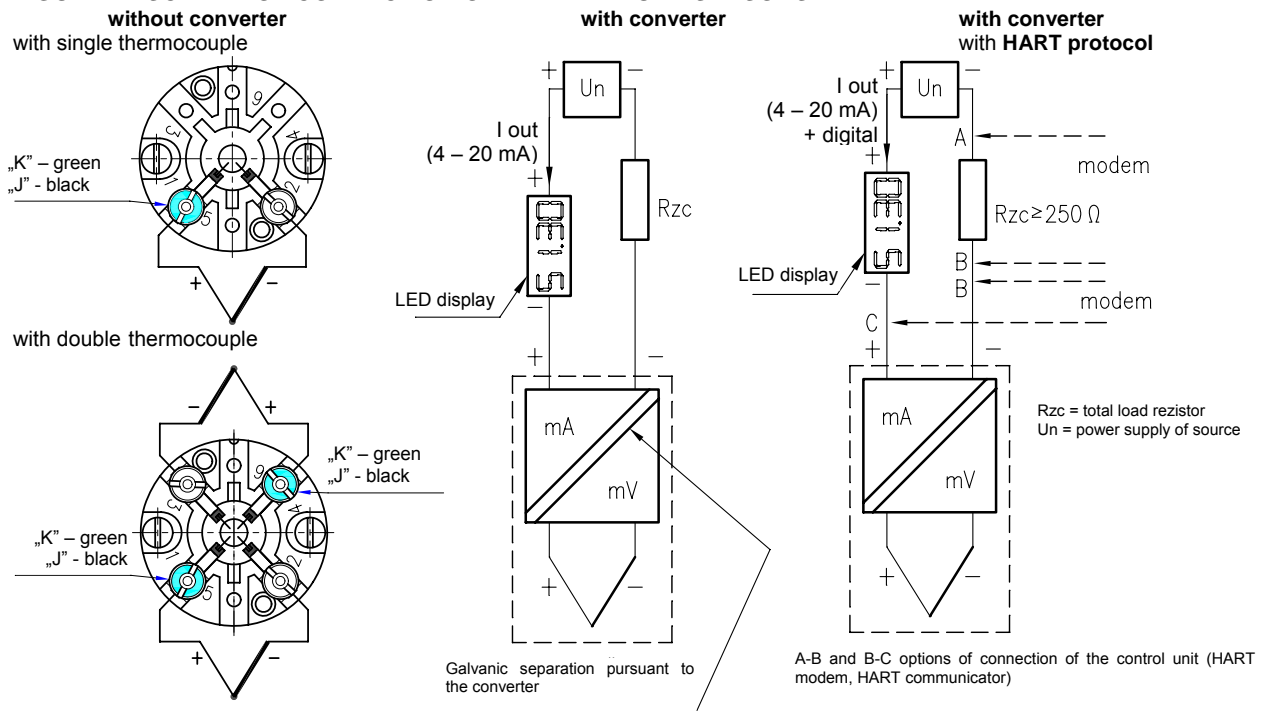

FIGURE 2 - EXAMPLE OF OPERATION CONNECTION OF TEMPERATURE SENSOR WITH CONVERTER IN LOOP 4 - 20 mA

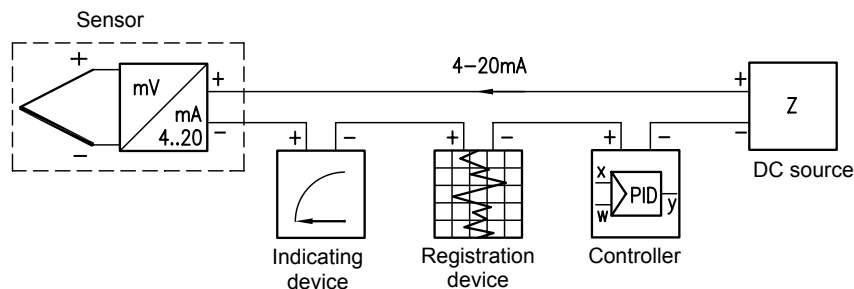
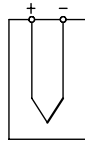

FIGURE 3 - DESIGN OF MEASURING ENDS OF JACKETED THERMOCOUPLES (SCHEMATIC ILLUSTRATION)

INSULATED END
design I
(standard for single design)



Jl

INDEPENDENT END
design U
(standard for double design)

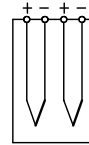

DU

September 2008
ZPA Nová Paka, a.s.



NOVÁ PAKA

