



Thermoelectric temperature sensor Ex d (Ex t, Ex i) with thermowell DIN without converter or with converter type series 330 type 334

PRODUCT MANUAL

**FOR DESIGNS WITH CONVERTER A MANUAL IS ENCLOSED TO THE RELEVANT CONVERTER
FOR DESIGNS WITH CONVERTER AND DISPLAY A MANUAL IS ENCLOSED TO THE RELEVANT CONVERTER AND DISPLAY**

APPLICATION

- For exact remote measurement of temperature of steady and running liquids (gases and fluids), for which the properties of the thermowell of the sensor are suitable; measurement may be realized up to max. temperature 450°C and nominal pressure PN 160
- For environment with explosive gaseous atmosphere according to EN 60079-10-1 and explosive atmospheres with combustible dust according to EN 60079-10-2
 - o Sensor may be installed into the thermowell located in zone 0 (20), zone 1 (21) or zone 2 (22), the thermowell for zone 0 shall comply with the requirements of EN 60079-26 (refer to figure 2)
 - o Other parts of the sensor (screw joint, adapter, connecting head) may be located in zone 1 (21) or zone 2 (22)
 - o Sensor without converter or converter with Ex ia version, when connected to Ex ia circuit according to EN 60079-25 in zone 0, 1, 2, 20, 21 and 22
- In a set with control or diagnostic systems for process monitoring
- In design with converter for transfer of thermoelectric sensor signal to unified output signal 4 to 20 mA or digital signal (converter with HART protocol)
- In design with display to display the value of the measured value
- For the environment, where mechanical resistance is required pursuant to EN 60068-2-6 (class AH2) and seismic capability of the electrical equipment of the safety system of the nuclear power stations pursuant to IEC 980 (MVZ level SL-2)

The sensors are rated products pursuant to the Directive 2014/34/EU, 2014/30/EU of the European Parliament and the Council and EU Declaration of Conformity **EU -334000** is issued for them.

DESCRIPTION

The sensor consists of a replaceable measuring insert with a flange and a ceramic terminal board or an installed two-wire converter (insulated or non-insulated, even in design Ex ia) and a protective armature consisting of a head and a thermowell with an adapter and a connecting screw-joint. The head with measuring insert and gland form a fixed closure Ex d. It is provided with a lid, which can be screwed, and a cable gland for the connecting wiring. The cable gland (pursuant to the required diameter of the cable) forms optional accessories to the sensor. The terminal board (of the converter) of the sensor is accessible after removing the lid of the head, which is fixed, after being tightened, with a pin against spontaneous releasing. The sensor is provided with an external clamp on the head for the connection of the grounding wire or wire for mutual interconnection.

The sensor with converter is supplied from an external source. The installed converter is pre-set to the required range at the sensor manufacturer.

To measure temperature, a defined change of thermoelectric voltage of the sensor in dependence on the change of temperature of the measured environment is used.

TECHNICAL DATA

The sensor design is based on DIN 43772. The sensor is designed pursuant to EN 61140 as an electric equipment of protection class III for the application in networks with category of overvoltage in installation II and pollution grade 2 pursuant to EN 61010-1; the follow-up (evaluation) device shall comply with Article 6.3 of the said standard.

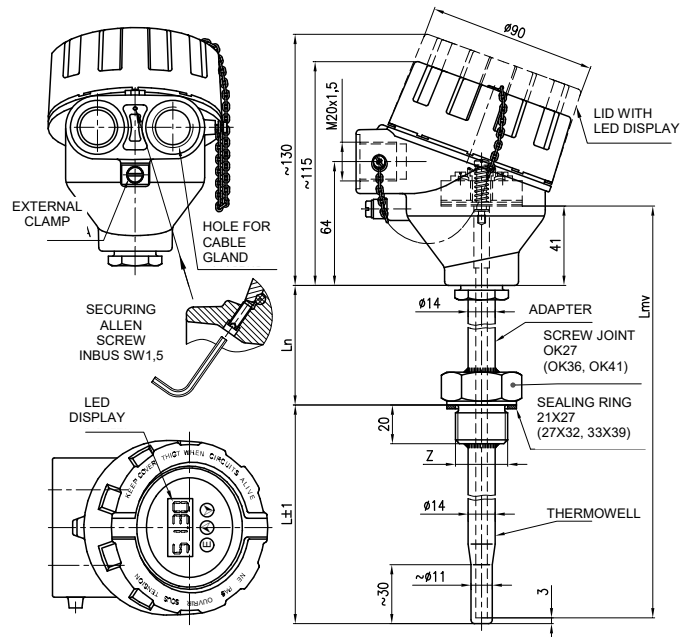

- L nominal length
 - L_n length of adapter
 - L_{mv} length of measuring insert
 - Z connecting thread of sensor adapter
- | | |
|--------------------------|------|
| $G\frac{1}{2}$, M20x1,5 | OK27 |
| G3/4, M27x2, 3/4-14NPT | OK36 |
| G1 | OK41 |

Measuring range:

Min. length of adapter L_n [mm]	Measuring range [°C]
100	-70 to 450 *)
40	-70 to 250

*)The upper limit of the range of measurement is limited by resistance of material of the used thermowell but it may not exceed 450°C.

If it is ensured in a suitable way that the surface temperature of the part of the sensor located in the dangerous area does not exceed the temperature of the required temperature class (T1...T6), the upper limit of the range of measurement may also be higher (max. 1150°C for thermocouple K, max. 800°C for thermocouple J). Example of installation - refer to Figure 2.

Measuring range of the sensor with converter is established by the range of the selected converter.

Design for explosive atmospheres:

Fixed closure pursuant to EN IEC 60079-0 and EN 60079-1,

Ex II 1/2 G Ex da/db IIC T1...T6 Ga/Gb

(Meaning of designation - refer to figure 6)

Dust-tight closure pursuant to EN IEC 60079-0 and EN 60079-31:

Ex II 1/2 D Ex ta/tb IIIC T=T media Da/Db

(Meaning of designation - refer to figure 6)

Intrinsically safe pursuant to EN IEC 60079-0 and EN 60079-11:

Ex II 1 G Ex ia IIC T5/T6 Ga

(Meaning of designation - see figure 7)

$P_i = 500$ mW T6 (-60°C ≤ T_a ≤ 68°C)

Intrinsically safe circuit parameters:

only for thermocouple "K" and "J", with measuring insert Ø6

$U_i = 60$ V $U_o = 100$ mV

$I_i = 100$ mA $I_o = 50$ mA

$P_i = 500$ mW $P_o = 25$ mW

$C_i = 850$ pF/m

$L_i = 16$ µH/m

! WARNING



The device must be installed in a housing that meets the degree of protection against intrusion of at least IP 20. The casing of the measuring insert is not separated from the inner intrinsically safe circuit according to the standard EN 60079-11. This information must be taken into account during installation.

Intrinsically safe version with converter:
according to built-in converter

Electric strength pursuant to EN 61010-1, Article 6.8.3:
500 V eff (only measuring insert without converter or design with insulated converter)

Electric insulation resistance pursuant to EN 61515, Article 5.3.2.4:
min. 1000 MΩ, at ambient temperature 20±15°C and max. 80% relative humidity, test voltage 500 V DC

Power supply of converter:
DC 24 V from source SELV, e.g. INAP 16 and INAP 901

Other data of converter: refer to the enclosed manual

Display: LED display to loop 4-20mA
other data refer to enclosed manual

Ingress protection pursuant to EN 60529
IP 68, 1m, 30 min

Operation position:
discretionary; the gland shall not be situated upwards

Type of operation: continuous

Sensor weight:
with adapter 110 mm 1.05 kg

Applied materials:

Thermowell	steel	1.4541 1.4571
Stem tube of measuring insert	for thermocouple of type "J"	Steel 1.4541
	for thermocouple of type "K"	INCONEL 600
Adapter	Steel 1.4541	
Head	Aluminium alloy painted with polyester paint	
	Steel 1.4401	
Sealing of lid of head and gland	Oil-resistant rubber	
Head terminals of terminal board	Brass with Ni surface	
Connecting items of sensor	Stainless steel	

OPERATION CONDITIONS

The environment is defined by the group of parameters and their severity grades IE 36 pursuant to EN 60721-3-3 and the following operation conditions.

- Ambient temperature for head and gland of the sensor:**
- for design without converter -50 °C ≤ Ta ≤ 85 °C
 - for design with converter pursuant to the type of converter (refer to the enclosed converter manual) max. -50 °C ≤ Ta ≤ 75 °C
 - for design with converter and display pursuant to the type of converter and display (refer to the enclosed converter and display manual) max -50 °C ≤ Ta ≤ 75 °C

Maximum surface temperature of the sensor:
it complies with maximum temperature of the measured medium

Maximum surface temperature for equipment operating in the environment with a threat of explosion of gases, steam and mist pursuant to EN 60079-0 and temperature class of the sensor are determined in dependency on the temperature of measured medium pursuant to the following table:

Temperature class	Maximum surface temperature	Maximum temperature of measured medium
T6	85°C	80°C
T5	100°C	95°C
T4	135°C	130°C
T3	200°C	195°C
T2	300°C	290°C
T1	450°C	440°C

Maximum permitted surface temperature for the equipment operating in the environment with a threat of explosion of dust pursuant to EN 61241-14:

- a) Temperature limitation due to occurrence of stirred dust:
 $T_{max} = 2/3 T_{ci}$
where T_{ci} is the temperature of ignition of stirred dust

- b) Temperature limitation due to occurrence of layers of dust to 5mm thickness:
 $T_{max} = T_{5\text{mm}} - 75\text{ °C}$
where $T_{5\text{mm}}$ is the temperature of ignition of dust layer 5mm thick

- c) Dust layers over 5 mm – refer to EN 61241-14
Maximum permitted surface temperature is defined by the lower value of the values specified above.

Intrinsically safe measuring inserts can be used in intrinsically safe circuits of group II electrical equipment.

! WARNING



The user shall guarantee that the maximum surface temperature of any part of the sensor does not exceed the temperatures of ignition of any gas, steam or dust, which can occur, due to effects of external thermal sources.

Relative ambient humidity:

- 10 to 100 % with condensation, with upper limit of water content 29 g H₂O/kg of dry air
- For design with converter pursuant to type of converter (refer to enclosed converter manual)
- For design with converter and display (refer to enclosed converter and display manual)

Atmospheric pressure: 70 to 106 kPa

Vibrations:

Sensor	with converter		without converter	
Nominal length L [mm]	130, 140, 170	220, 260	130, 140, 170	200, 260
Frequency range [Hz]	10 to 500			
Drift amplitude [mm]	0.2	0.15	0.5	0.2
Acceleration amplitude [ms ⁻²]	29.4	19.6	68.7	39.2

Maximum speed of flow of liquids:

Nominal length L [mm]	130	140	160	220	280
Water steam, gas, air [m/s]	50	35	25	10	8
Water [m/s]	5	4	3	3	3

METROLOGICAL DATA

Sensing probe: measuring thermocouple J (Fe-CuNi) or K (NiCr-NiAl) pursuant to EN 60584-1, Ø 6 or Ø 3 mm, tolerance class 2 or 1, single with insulated measuring end or double with independent measuring end

Output signal

- of analogue converter (linear with thermoelectric voltage):
4 to 20 mA
- of programmable converter (linear with measured temperature):
4 to 20 mA (+ digital for HART protocol)

Calibration depth of immersion of the measuring insert of the sensor

- for temperature points within range -70 to 250°C:
200 mm (min. 160 mm)
- for temperature points above 250°C:
300 mm (min. 260 mm)

The distance of flange of the measuring insert from the level of medium in the calibration bath shall be at least 40 mm at temperatures to 250°C and min. 70 mm at temperatures above 250°C.

Temperature response time pursuant to EN 60751 in whirling water (characteristic value):

with thermowells, shape 3G pursuant to DIN
L = 130, 140, 160, 220 and 280 mm
 $\tau_{0,5}$ 25 s
 $\tau_{0,9}$ 75 s

DESIGNATION :

Data of head label

- Trademark of the manufacturer
- Made in Czech Republic
- Type of thermoelectric sensor / tolerance class
- Measuring range or set-up converter range
- Product ordering number
- Ingress protection
- Serial number
- Output signal 4 to 20 mA (design with converter)
- Ambient temperature
- Designation of non-explosiveness:
 - Ex II 2 G Ex db IIC T1...T6 Gb
 - Ex II 2 D Ex tb IIIC T=T media Db
 - Ex II 1 G Ex ia IIC T5/T6 Ga

- EU-Type Examination Certificate number
- Designation of non-explosiveness and EU-Type Examination Certificate number (for design with converter Ex ia)
- CE mark 1026

Data on label of measuring insert

- Trade mark
- Sensor type / tolerance class
- Serial number

Data on converter label

- Trademark
- Sensor type
- Pre-set temperature range
- Designation of non-explosiveness and EU-Type Examination Certificate number for design with converter Ex ia
- CE mark with identification number of the notified person (for design with converter Ex ia)

Data on display

- Trademark
- CE mark

RELIABILITY

Indicators of reliability in operation conditions and ambient conditions specified herein

- Medium time of operation between failures 96 000 hours (inf. value)

Expected service life 10 years

DELIVERY

Unless agreed otherwise with the customer, each delivery includes

- Delivery note
- Sensor pursuant to the purchase order
- Sealing ring
 - o 21x27 TPD 62-014-91 for connecting thread G ½ and M20x1,5
 - o Cu 27 x 32 x1.5 (ČSN 02 9310.2) for thread M27 x 2 and G¾
 - o Cu 33 x 39 x 2 (ČSN 02 9310.2) for thread G1 (for thread 1/2-14NPT, the sealing ring is not delivered)
- Allen key 1.5 mm
- Separately ordered accessories; pursuant to the catalogue of, type 991:
 - o Suitable thermowells and nipples
 - o Suitable cable gland. An instruction sheet is delivered with each cable gland
- Optional accessories to the sensor with programmable converter
 - o Configuration (parameterization) programme pursuant to the required converter
 - o Communication modem (for serial port RS 232C) pursuant to the required converter
- Accompanying technical documentation in Czech
 - o Product manual
 - o Product quality and completeness certificate, which also serves as the warranty certificate
 - o EU Declaration of Conformity

If it is established in the purchase contract or agreed otherwise, the following documentation can be also delivered with the product

- Copy of the Inspection Certificate 3.1 for material of thermowell with the heat number
- Calibration sheet (for uncertified calibrated design)
- Test report about the seismic and the vibration qualification
- Copy of EU-Type Examination Certificate pursuant to the Directive No 2014/34/EU for fixed closure and dust-tight closure
- Copy of EU-Type Examination Certificate pursuant to the Directive No 2014/34/EU for Ex ia design

CERTIFICATION

- Non-explosiveness Ex ia, EU-Type Examination Certificate pursuant to the Directive 2014/34/EU FTZÚ 08 ATEX 0200X as amended
- Non-explosiveness Ex ia, EU-Type Examination Certificate pursuant to the Directive 2014/34/EU FTZÚ 21 ATEX 0007X

- Non-explosiveness Ex ia, EU-Type Examination Certificate pursuant to the 2014/34/EU (pursuant to the type of the converter and display)

CALIBRATION

It is realized pursuant to TPM 3322-94 and in compliance with EN 584, usually in three temperature points evenly distributed within the operation range of the sensor or in the points according to the requirement of the customer. Calibration sheets with measured data are issued for calibrated sensors.

PACKING

Both sensors and accessories are delivered in a packing ensuring resistance to the impact of thermal effects and mechanical effects pursuant to controlled packing regulations.

STORAGE

The products may be stored on conditions corresponding to the set of combinations of classes IE 12 pursuant to EN IEC 60721-3-1, but with ambient temperature from -20 to 70 °C (i.e. in places without control of temperature and humidity, with danger of occurrence of condensation, dropping water and formation of ice, without a special threat of an attack with biological agents, with vibrations of small significance and not situated close to sources of dust and sand).

TRANSPORT

The sensors may be transported on conditions corresponding to the set of combinations of classes IE 21 pursuant to EN IEC 60721-3-2 (i.e. by airplanes and trucks, in premises that are ventilated and protected against atmospheric conditions).

ORDERING TEMPERATURE SENSORS

The purchase order shall specify

- Name
- Product ordering number
- Ex ia design is ordered using codes JIX, or DUX according to Table 1
- Additional requirements for sensor design pursuant to Table 2
- Request for other documentation pursuant to Table 2
- Measuring range
- If calibration is required and in what temperature points
- If the delivery of a nipple pursuant to the type 991 is required for the sensor as accessories
- If the delivery of gland for output cable pursuant to the type 991 is required for the sensor as accessories
- If optional accessories to the sensor with programmable converter is required
- Request for other documentation according to Article DELIVERY
- Other (special) requirements
- Number of pieces

Behind the ordering number specified pursuant to the above mentioned table, the customer shall identify the required range of measured temperature (i.e. lower and upper temperature limits in °C) and, as the case may be, other non-standard required parameters for converter configuration (e.g. indication of sensor tripping, dampening, required designation - tagging etc.).

PURCHASE ORDER EXAMPLE**Standard design:**

Thermoelectric temperature sensor Ex d (Ex t) with thermowell DIN without converter
334 412 111 K2/JI/Q4
Calibration points 250, 350 and 450°C
Range -70 to 450°C
6 pcs

Special requirement:

Thermoelectric temperature sensor Ex d (Ex t) with thermowell DIN with converter
334 912 111 J2/HCF
nominal length L = 380 mm, range 0 to 300°C
6 pcs

ORDERING ACCESSORIES

The purchase order shall specify:

- Name
- Ordering number
- Number of pieces

EXAMPLE OF PURCHASE ORDER

Standard design:

1. Nipple
991 NVP4 M27 72
6 pcs
2. Cable gland
991 VM 612
6 pcs

Special request:

- Nipple
991 NVP4 D27 99
material 1.5415
6 pcs

TABLE 1 - DESIGN OF TEMPERATURE SENSORS Ex d (Ex t, Ex i) WITH THERMOWELL, DIN - TYPE 334

SPECIFICATION					ORDERING NUMBER															
					334	x	x	x	x	x	x	x	x	x	/xxxxxx	/xxx				
Nominal length L [mm]	130	Length of adapter L _n [mm]	107	Length of measuring insert L _{mv} [mm]	275	1														
	160				2															
	220				3															
	280				4															
	400				5															
	Other (min. 130) *)				9															
Nominal length L [mm]	130	Length of adapter L _n [mm]	47	Length of measuring insert L _{mv} [mm]	215	1														
	160				2															
	220				3															
	280				4															
	400				5															
	Other (min. 130) *)				9															
Length of adapter L _n [mm]	110mm (100mm)					1														
	47 mm *) max. -70 to 250°C					2														
	Other **) (min. 47 mm)					9														
Thermowell material	1.4571 ***** max. measuring range -70 to 400°C									1										
	1.4541 ***** max. measuring range -70 to 450°C *****									2										
	Other *) *****									9										
Connecting thread	G1/2										1									
	G1										2									
	M27x2										3									
	G3/4										4									
	3/4-14 NPT										5									
	Other *)										9									
Head of sensor with thread for gland Ex d (Ex t)	Aluminium alloy painted with blue epoxy colour		M20x1.5								1									
			1/2-14NPT								2									
	Corrosion-resistant steel		M20x1.5								3									
	1.4401		1/2-14NPT								4									
Tube of measuring insert for sensor with thermowell (Ø6 ± 0,1 mm)																1				
Thermocouple	K																	K		
	J																	J		
Accuracy class	1 *)																	1		
	2																	2		
Design of measuring ends of thermocouple pursuant to figure 5	Single thermocouple, insulated end																	/JI		
	Double thermocouple, independent end																	/DU		
	Single thermocouple, insulated end		only for TC "K" a "J", length of measuring insert L _{mv} 100 – 3025 [mm]									1						/JIX		
	Double thermocouple, independent end											1						/DUX		

TABLE 1 - DESIGN OF TEMPERATURE SENSORS Ex d (Ex t, Ex i) WITH THERMOWELL, DIN - TYPE 334
(continuation)

SPECIFICATION					ORDERING NUMBER															
					334	x	x	x	x	x	x	x	x	x	/xxxxxx	/xxx				
Converter (design of thermocouple measuring ends: single thermocouple, isolated end)	Converter type		Galvanic separation	Ex ia	NFC	Range [°C]														
	Analogue linear output signal with thermoelectric voltage	APAQ-HCF					Adjustable range												/HCF	
		APAQ-HCFX			•															/HCFX
	Programmable linear output signal with temperature	TH 200	•				Programmable range												/TH200	
		TH 200-ex	•		•															/TH200X
		IPAQ-H	•																	/IPAQH
		IPAQ-HX	•		•															/IPAQHx
		MINIPAQ-H																		/MINIPAQ
		IPAQ C202																		/C202
		IPAQ C202X			•															/C202X
		IPAQ C330	•			•														/C330
	IPAQ C330X	•		•	•														/C330X	
	Programmable with HART protocol linear output signal with temperature	IPAQ C520	•																	/C520
		IPAQ C520S *****)	•																	/C520S
		IPAQ C520X	•		•															/C520X
		IPAQ C520XS *****)	•		•															/C520XS
		IPAQ C530	•			•														/C530
		IPAQ C530X	•		•	•														/C530X
		TH 300	•																	/TH300
		TH 300-ex	•		•														/TH300X	
	MESO-H	MESO-H	•																/MESOH	
		MESO-HX	•		•														/MESOHX	
248 HA NA		•																/248HANA		
248 HA I1		•		•														/248HA1X		
644 H NA		•																/644HNA		
644 H I1 *)		•		•														/644HI1X		
Other *)																		/99		
Without converter (for installation of the converter by customer)																		/00		
LED display to loop 4-20 mA (not possible with head from corrosion resistant steel) (only with converter APAQ-HRF, MINIPAQ-HLP)						LPI-02												/LD		

Standard design

- *) Only as a special requirement after an agreement with the manufacturer
- **) In case of adapter length below 100 mm (minimum 40 mm), the temperature range is decreased to -70 to 250 °C.
- ***) For zone 0, it is necessary to use a thermowell from corrosion resistant steel (pursuant to EN 60079-26)
- ****) Up to 600 ° C in the mounting method pursuant Figure 2
- *****) Thermowells of these materials are suitable for contact with food
- *****) Functional safety SIL2

TABLE 2 – ADDITIONAL REQUIREMENT FOR DESIGN OF TEMPERATURE SENSORS Ex d (Ex t) TO THERMOWELL, TYPE 333

SPECIFICATIONS			CODE
CALIBRATION	NUMBER OF CALIBRATION POINTS	CALIBRATION RANGE	
Calibration by TPM 3342-94, define calibration points	3	0 to 800 °C	/Q4
	3	0 to 1100 °C	/Q42
	Other	0 to 1100 °C	/Q9
REQUIREMENT FOR OTHER DOCUMENTATION		USE	
EU Declaration of Conformity		for design with converter	/EU
Copy of EU-Type Examination Certificate acc to the 2014/34/EU (ATEX)		for Ex ia design	/Exi
Copy of the Inspection Certificate 3.1 acc to EN 10204 for material of tube with the heat number			/3.1
Declaration of Conformity with purchase order 2.1 pursuant to EN 10204			/2.1

Specify the code behind ordering number. Define calibration points for codes Q4, Q42 a Q9.

TABLE 3 – ACCESSORIES - OVERVIEW OF DESIGNS RECOMMENDED NIPPLES FOR WELDING THERMOWELLS, TYPE 991 (order separately)

SPECIFICATION					ORDERING NUMBER							
					991	xxx	x	xxx	xx			
Shape	Direct nipple					NVP						
	Oblique (chamfer 45°)					NVS						
Internal bore	M20x1,5	for embed sealing ring	PN	40			1	M20				
	G 1/2							G12				
	M20x1,5	without embed for sealing ring							2	M20		
	G 1/2								G12			
	M27x2			160					4	M27		
	G 3/4									G34		
	3/4 – 14 NPT										N34	
	G1										G01	
Other *)									999			
Material	1.0308 or 1.0122	surface treatment	preservation with grease – oil	maximum operation temperature [°C]	300 (only PN 40)				M20	13		
	1.0577				400				G12			
	15 128.5				550				M27			
	1.4541				550				G34			
	Other *)				pursuant to material				N34		51	
					pursuant to material							G01

*) upon a special requirement after an agreement with the manufacturer

TABLE 4 - OVERVIEW OF DESIGNS AND ORDERING OF CABLE GLANDS Ex d (Ex t) BRASS – TYPE 991

SPECIFICATION							Ordering number				
							991	xx	xxx		
Gland Ex d (Ex t) brass		Cable clamp (clamping module)			Thread	Torque of gland body	For cable Ø [mm]				
Size	Wrench		Size	Dimension							
	A	B		C	Ds						
No. 4	OK 17	OK 24	No. 4	5	20	M20x1.5	30 - 35 Nm	4,5-8.5		VM	458
No. 5	OK 19		No. 5	5	22			7-11		VM	711
No. 6	OK 24		No. 6	6	27.5			10-16		VM	016
No. 4	OK 17		1/2-14 NPT	No. 4	5	20	25 - 30 Nm	4,5-8.5		VK	458
No. 5	OK 19			No. 5	5	22		7-11		VK	711
No. 6	OK 24			No. 6	6	27.5		10-15.5		VK	015

TABLE 5 –OVERVIEW OF SEALING RINGS TYPE 991 SUPPLIED TO TEMPERATURE SENSORS

EXTERNAL FIXING THREAD OF TEMPERATURE SENSORS	SEALING RING			ORDERING NUMBER
	DIMENSION [mm] Ød x ØD x t	MATERIAL	NUMBER	
M20x1,5	21x27x2	copper thermally insulating insert	1 Pcs	991 TK 21
G1/2				
M27x2	27x32x1,5	copper		991 TK 27
G3/4				
G1	33x39x2			991 TK 33
3/4-14 NPT	-	-		-

The sealing ring is supplied to each sensor by default, only for the sensor with internal thread 1/2-14NPT the sealing ring is not supplied. The sealing ring can also be ordered separately using ordering number

INSTALLATION AND CONNECTION

SENSOR INSTALLATION

Install the sensors by screwing into the nipple on the piping (technological equipment) or welded into the piping wall. Before the installation, put on the enclosed sealing ring in advance (for thread 1/2-14NPT, the sealing ring is not used). During the installation, torque of 70 Nm is recommended, for thread M20 x 1,5, G 1/2 and 3/4-14NPT and. torque of 150 Nm it is recommended for thread M27 x 2 a G3/4.

Examples of application of nipples are provided in Figure 1 With respect to maintaining metrological properties and the longest possible service life, it is not recommended to install the sensors in places with high turbulence of the medium, which is caused e.g. by a rapid transition from a small diameter of the piping to a larger one (when failing to comply with the required shape and dimensions of diffuser behind the flow meter), etc. Recommended distance of the temperature sensor from the installation flange of the flow meter is min. 1 m.



WARNING



The thermowell of temperature sensor may be install in the zone 0 (20), zone 1 (1) or zone 2 (22), The other parts of the sensor (fitting, adapter, connecting head) may be located in zone 1 (21) or zone 2 (22).

When installing sensor in the thermowell located in zone 20, a pre-fuse with the following parameters must be used in the converter encoder circuit: Ceramic, quick break (F), short circuit resistance 1500A (H), e.g. ceramic tube fuse Ø5 x 20 mm, F100mA.

Distance of the fixed closure Ex d IIC from close structures or between the closures shall be at least 40 mm.

The temperature sensor with a paint finish must be installed in an explosive atmosphere with dust so as to avoid the occurrence of creep discharges

INSTALLATION OF CABLE GLAND

Only a certified cable gland shall be used to secure the fixed closure (dust-tight closure) Ex d IIC (Ex tb IIIC) with IP 68 protection (see accessories type 991 or another similar gland). For temperature sensors with converter, a barrier cable gland must be used in zone 1 of the IIC gas gauge, or an Ex ia converter.

The gland shall be tightened in the sensor head in the prescribed way.

Torque of gland body:

- | | | |
|----|-----------------------------------|-----------|
| a) | for gland with thread 1/2 - 14NPT | 25 – 30Nm |
| b) | for gland with thread M20x1.5 | 30 – 35Nm |

Installation of the cable in the gland, its sealing and securing against pull-out shall be realized pursuant to the instruction sheet of the gland supplier.



WARNING

Do not use other sealing rings in the gland than the original ones delivered by the manufacturer. Do not change artificially the outer diameter of the cable e.g. by winding it around with electrical insulating tapes.

ELECTRICAL CONNECTION

The electrical connection may be only realized by qualified workers.

The sensor installation in conditions with explosive gaseous atmosphere or flammable dust shall comply with the requirements of EN 60079-14.

The sensor installation in conditions with flammable dust shall comply with the requirements of EN 61241-14.

The terminal board of the sensor (converter) is accessible after unscrewing the lid of the head.

Connect the evaluation devices to the sensor with a cable with double insulation; internal wires with Cu core (sensor with converter) or compensation wiring (sensor without converter) 0.5 to 1.5 mm². Sensors without converter connect with unarmoured shielded compensation or double insulated thermocouple wiring with cross section 0.5 to 1.5 mm² and outer diameter according to cable gland.

Seal the cable in the gland by prescribed tightening of the closing nut pursuant to instruction sheet of the gland. Then secure it with clamp against pull-out.



WARNING

The connecting cable must have a casing of thermoplastic, thermoset or elastomeric materials. The cable must be circular and compact, the filler or shell must be extruded and the filler material, if used, must be non-absorbent. The length of the connecting cable must be at least min. 3 m. Temperature resistance of the cable shall comply with the ambient temperature!

The cable insulation shall have chemical and mechanical resistances in compliance with the conditions, in which the cable will be installed. It is recommended supporting the cable along its length between the sensor and the follow-up device. In the environment with interfering signals, use shielded cable in the power supply circuit. Shielding may be only grounded (earthed) in one point. The cable should not be placed together with power cables.

In case of the sensor with HART protocol converter, the maximum length of wiring is defined by the arrangement of wires of the connecting cable. The total length of wiring may be up to 1500 m. It requires a twisted two-wire with shared shielding with the diameter of the cross section min. 0.5 mm². Recommended HART communicator, model 275, is connected to the power supply loop of the sensor with converter pursuant to Figure 4. To achieve reliable communication, resistor 250 Ω shall be introduced in the circuit of the output loop.



WARNING

Programmable converter may not be connected to a computer or a HART communicator if the converter is located in explosive environment. Surface temperature of the converter may not exceed maximum surface temperature for that particular temperature class.

For the installations in dangerous areas, mutual connection is required (bringing to the same potential). To achieve it, terminals on the sensor head can be used.

The sensor need not be connected to the system of mutual connection independently if it is installed firmly and has metal interconnection with structural parts or the piping, which is connected to the system of mutual connection.

Maximum cross-section of wire for connection to external and internal terminals:

Internal terminal: stranded wire 1.5 mm², full wire 2.5 mm²

External terminal: stranded wire 4.0 mm², full wire 6.0 mm²

If stranded wires are used for the interconnection, they shall be protected against fraying with pressing hollow.

SENSOR HEAD WITH TERMINALS

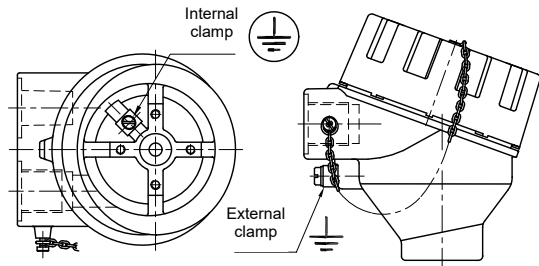

CLOSING HEAD OF FIXED CLOSURE Ex d

After electrical connection of the sensor, the lid of the head shall be fully tightened by hand, then released slightly to ensure matching with the closest groove against the securing pin and fixed by this screw against releasing. If the lid of the sensor is not tightened and secured by the above mentioned screw, the sensor does not comply with the requirements of fixed closure Ex d.



WARNING:

Electric supply of the sensor may not be connected before closing the fixed closure!



SENSOR INSTALLATION WITHOUT CONVERTER AND SENSOR WITH CONVERTER Ex ia TO ZONE 0 (20)



WARNING:

The user is responsible for ensuring that during operation in zone 0 is between the sensor head from an aluminium alloy and other equipment preclude any risk of ignition due to impact and friction.



The sensor without converter can be used, in case of the installation pursuant to EN 60079-11, Art. 5.7 in the intrinsically safe circuit Ex ia according to EN 60079-25), as a simple equipment. For simple equipment, the maximum temperature can be determined from the value of the P₀ of the follower and the temperature class is determined.

Sensor with converter Ex ia can be used while adhering to the Ex ia parameters of the converter shall be complied with pursuant to the enclosed converter manual.

In intrinsically safe circuits, only insulated cables that are capable of withstanding an electrical strength test with a voltage equal to twice the voltage in the intrinsically safe circuit or 500 V eff (DC 750 V) must be used, with a larger value being taken.

When installing intrinsically safe circuits, including cables, do not exceed the maximum allowable inductance, capacity or ratio LiR and surface temperature. Permissible values are determined from the documentation of the connecting device or label. Place follow-up equipment out of the danger area. An intrinsically safe source approved for supplying intrinsically safe devices in accordance with EN 60079-11 must always be used.

The shield of the intrinsically safe circuit cable must be grounded in the same place as the intrinsically safe circuit, the connection must be outside the dangerous area.

If the intrinsically safe circuit is isolated from the ground, the shield must be connected in one place to the protective interconnection system. This can be using the terminals on the sensor head.

COMMISSIONING

After the sensor installation, including closing the fixed closure, and connection of the follow-up (evaluation) device to the supply voltage (and the settlement period of the converter), the equipment is prepared for operation.

WARNING
 After installation must be require initial inspection equipment and installations according to EN 60079-17

OPERATION AND MAINTENANCE

The sensor does not require any operation and maintenance and follow-up periodical revisions or permanent supervision of expert staff shall be carried out pursuant to EN 60079-17.

WARNING
 Any intervention into the sensor and its structure will result in a change of properties and can result in an explosion!

SENSOR UNINSTALLATION

WARNING
 Temperature sensor is in design Ex and must be disconnected from the supply source before opening the lid of the head and releasing the cable gland in the explosive environment!

Release the securing screw of the lid by ALLEN key 1.5 mm (a part of accessories). The terminal board of the sensor (converter) is accessible after unscrewing the lid of the head. Measuring insert of the sensor can be replaced and is uninstalled from the head after disconnecting the cable by releasing two screws.
 Before a complete uninstallation of the sensor, the wire for mutual interconnection shall be released from the external terminal on the sensor.
 Disconnect the connecting cable from the terminal board, then release it from the clamp on the gland and from closing nut of the gland.
 Unscrew the sensor from the thermowell; torque for releasing is approx. 70 Nm for thread M18 x 1,5, G1/2 a M20 x 1,5, approx. 50 Nm for thread M14 x 1,5 and approx.40 Nm for thread 1/2-14NPT. While releasing the screw-joint of the sensor, the thermowell may never be released.

SPARE PARTS

Spare parts shall be delivered by the manufacturer. Relevant measuring inserts can be ordered pursuant to following table.

SPECIFICATIONS		ORDERING NUMBER					
		MV330	/xxx/	x	x	x	/xxxx
Length of measuring insert [mm]							
ø measuring insert [mm]	6 ± 0,1			1			
	3 ± 0,1			3			
Sensing probe	Thermocouple K				K		
	Thermocouple J				J		
Accuracy class	1					1	
	2					2	
Connection of the terminal board and design of measuring ends of thermo-couple or converter	Single thermocouple, insulated end						/JI
							/JIX *)
	Double thermocouple, independent end						/DU
							/DUX *)
Converter pursuant to tab. 1							/converter

*) Ex ia design(only with measuring insert ø 6, length of measuring insert L_{mv} 100 – 3025 [mm])

EXAMPLE OF PURCHASE ORDER OF MEASURING INSERT

Thermoelectric measuring insert without converter
 330 /375/ 1K2/JI
 6 pcs

To order the certified measuring inserts, specify the code according to Table 2 – Additional requirements – behind the ordering number.

The measuring inserts are marked according to Article DESIGNATION. Designation is completed with the ordering number.

Each delivery includes

- Delivery note
- Measuring insert pursuant to the purchase order
- Optional accessories to the measuring insert with a programmable converter
 - o Configuration program according to the required converter
 - o Communication modem (for serial port RS 232C) according to the required converter
- Accompanying technical documentation in Czech
 - o Product manual
 - o Product quality and completeness certificate, which also serves as the warranty certificate
 - o EU Declaration of Conformity (for Ex ia design)

If it is established in the purchase contract or agreed otherwise, the following documentation can be also delivered with the product

- Calibration sheet (for calibrated design)
- EU Declaration of Conformity (for design with converter)
- Copy of EU-Type Examination Certificate pursuant to the Directive No 2014/34/EU for Ex ia design

WARRANTY

The warranty period is 24 months from the receiving of the product by the customer, unless established otherwise in the contract. Rejection of defects shall be enforced in writing at the manufacturer within the warranty period. The rejecting side shall identify the product name, ordering and manufacturing numbers, date of issue and number of the delivery note, clear description of the occurring defect and the subject of the claim. If the rejecting side is invited to send the device for repair, it shall do so in the original package of the manufacturer and/or in another package ensuring safe transport.

The warranty shall not apply to defects caused by unauthorized intervention into the device, its forced mechanical damage or failure to comply with operation conditions of the product and the product manual.

REPAIRS

The sensors shall be repaired by the manufacturer. They shall be sent for repair in the original or equal package without accessories.

DISABLING AND LIQUIDATION

The product and its package do not include any parts that could impact the environment.

Products that are withdrawn from operation, including their packages (with the exception of products marked as electrical equipment for the purposes of return withdrawal and separate salvage of electrical waste), may be disposed of to sorted or unsorted waste pursuant to the type of waste.

The manufacturer realizes free return with withdrawal of marked electrical equipment (from 13.8.2005) from the consumer and points out the danger connected with their illegal disposal. The package of the sensor can be recycled completely. Metal parts of the products are recycled, non-recyclable plastic materials and electrical waste shall be disposed of in accordance with applicable legislation.

FIGURE 1 - DESIGN OF MEASURING ENDS OF JACKETED THERMOCOUPLES (SCHEMATIC ILLUSTRATION)

INSULATED END design I (standard for single design) INDEPENDENT END design U (standard for double design)

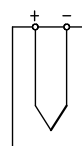

J1

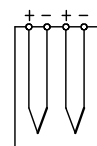

DU

FIGURE 2 - SCHEME OF CONNECTION OF TEMPERATURE SENSORS

SCHEME OF CONNECTION WITHOUT CONVERTER

with single thermocouple

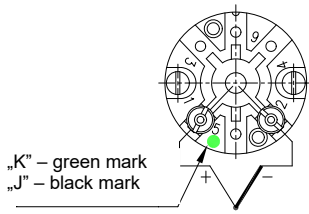

with double thermocouple

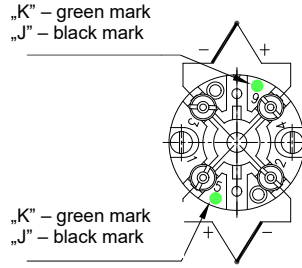

SCHEME OF CONNECTION WITH CONVERTER AND DISPLAY

with converter

with converter with HART protocol

with converter Ex ia

with converter Ex ia with HART protocol

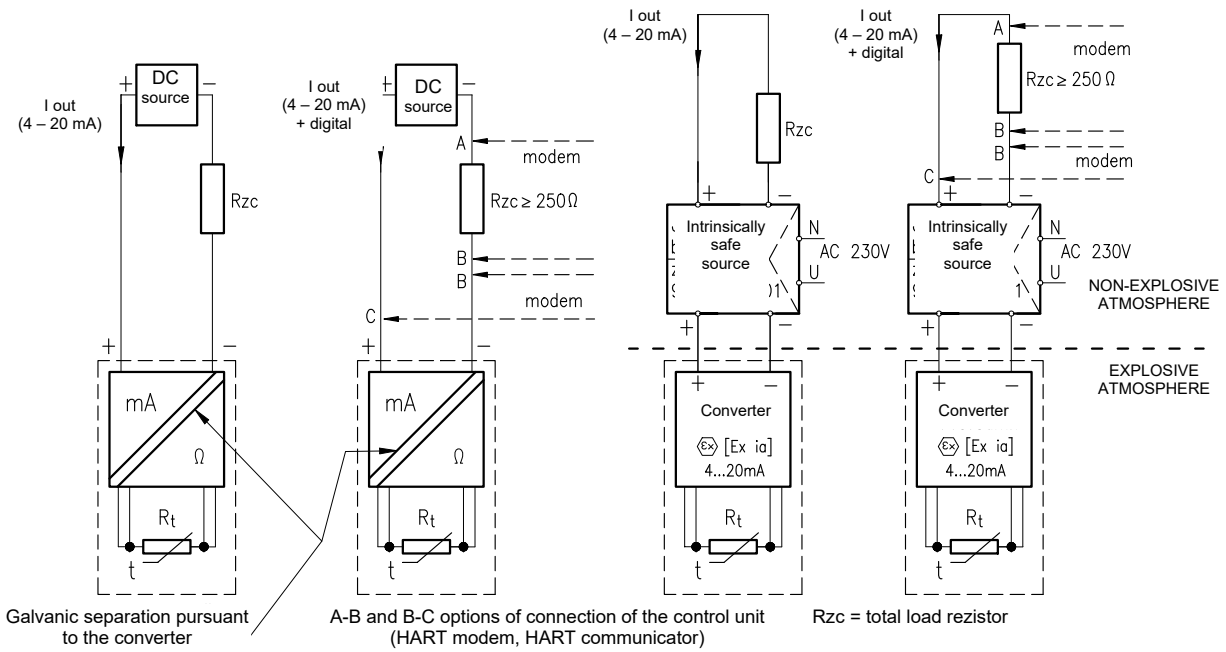

FIGURE 3 - EXAMPLE OF OPERATION CONNECTION OF TEMPERATURE SENSOR WITH CONVERTER IN LOOP 4 - 20 mA

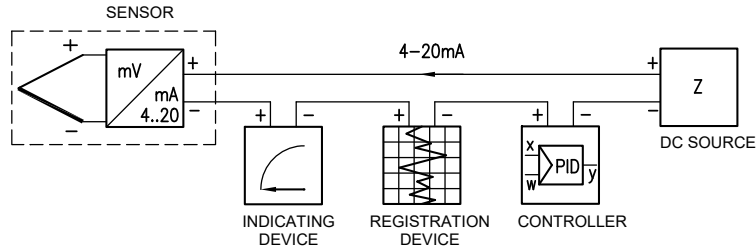
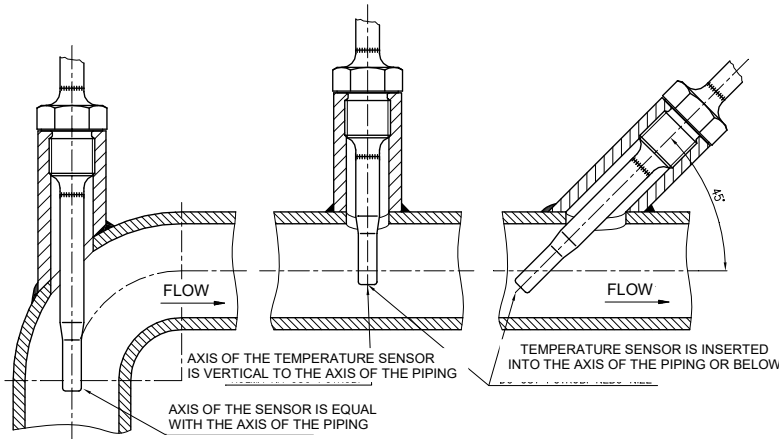

FIGURE 4 – EXAMPLES OF INSTALLATION OF DIRECT AND OBLIQUE NIPPLES PURSUANT TO EN 1434-2



! WARNING

- When using the sensor with an oblique nipple, locate the sensor with thermowell at an angle against the direction of flow
- The sensor may not touch the opposite side of the piping
- It is also advantageous to use the temperature sensors in the piping elbow. In such a case, locate the sensor with the thermowell against the direction of flow so that the measured medium flows around evenly

FIGURE 5 - EXAMPLES OF INSTALLATION OF TEMPERATURE SENSORS Ex d WITH METAL PROTECTIVE TUBE
 (in case a higher upper limit of the range of measurement is required than the required temperature class)

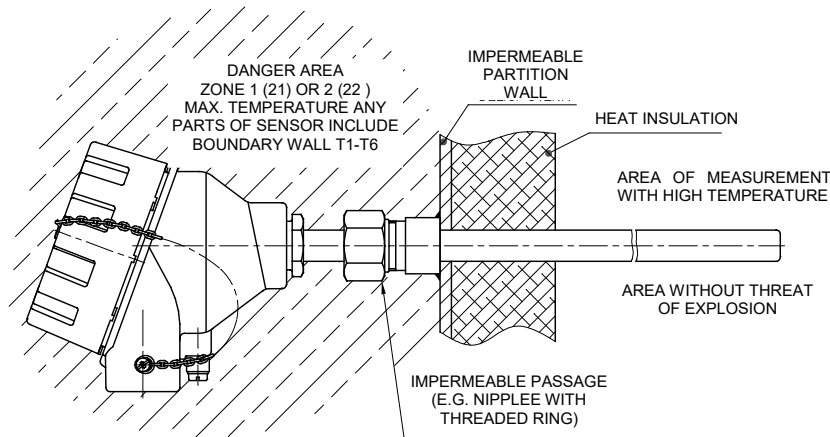

FIGURE 6 – MARK OF NON-EXPLOSIVENESS

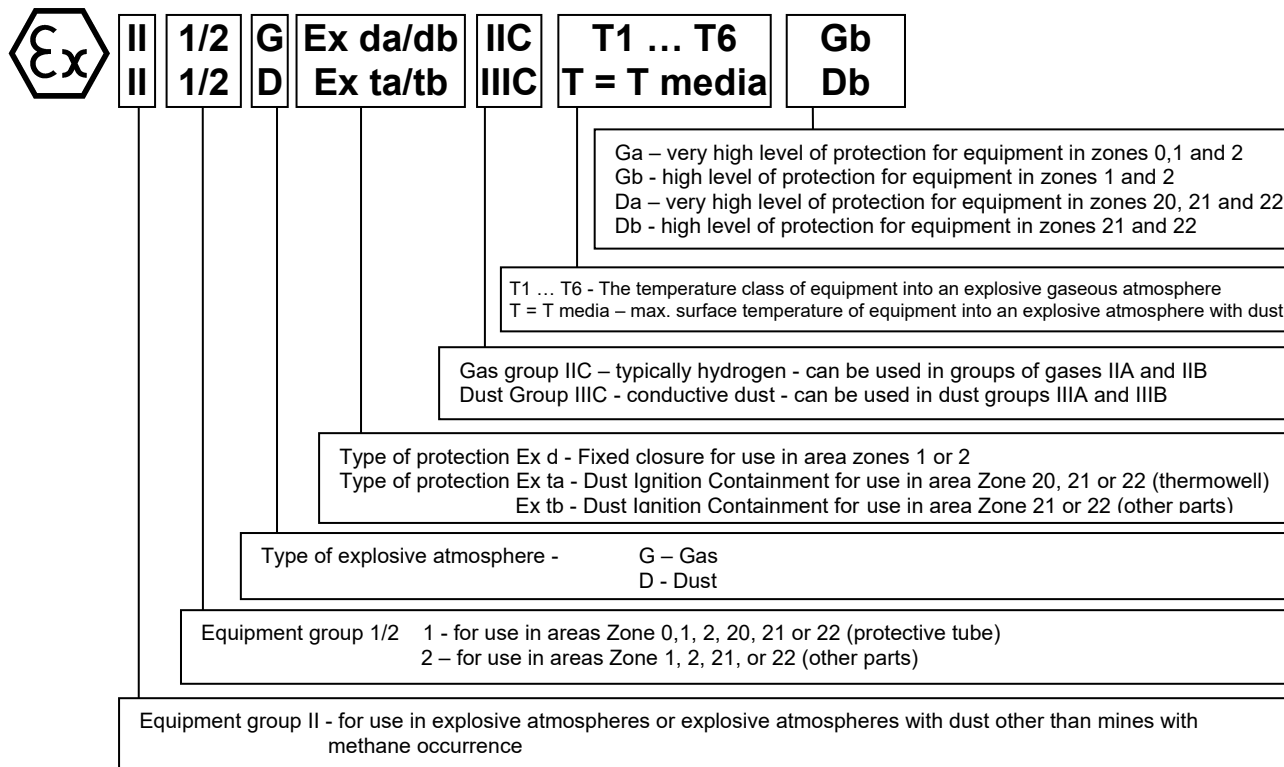
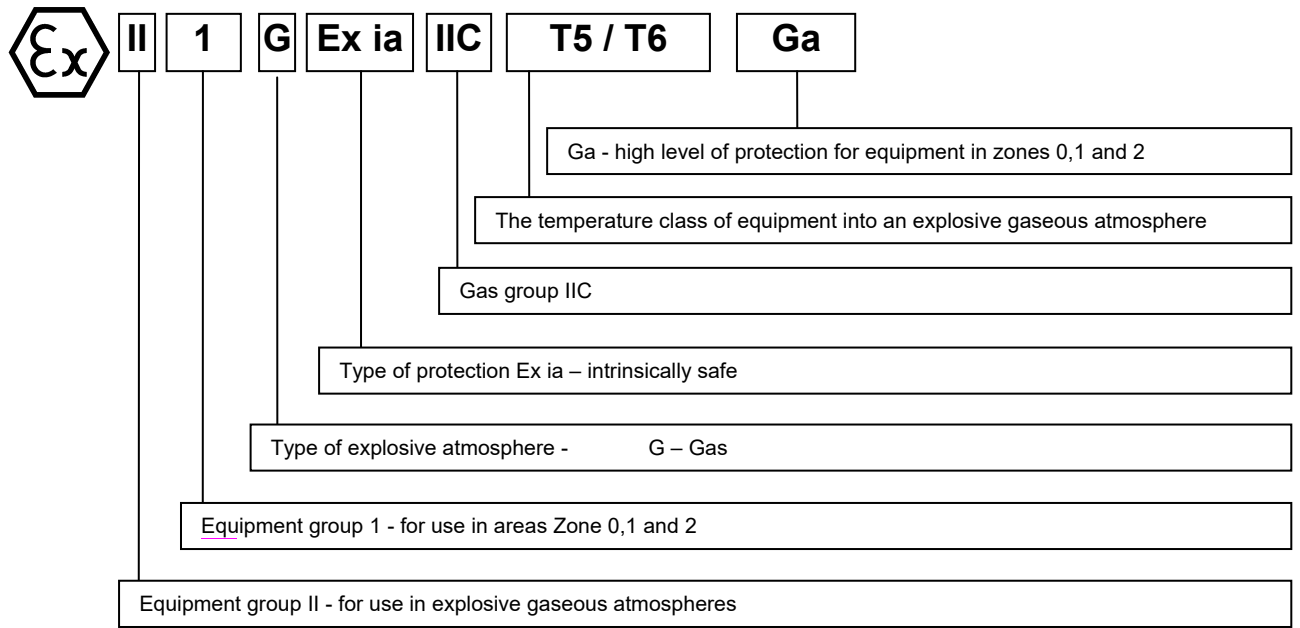

FIGURE 7 - INTRINSICALLY SAFE MARKING



April 2021

© ZPA Nová Paka, a.s.

