



Thermoelectric temperature sensor Ex d (Ex t, Ex i) to thermowell ČSN without converter or with converter type series 340 type 343

PRODUCT MANUAL

**FOR DESIGN WITH CONVERTER A MANUAL IS ENCLOSED TO THE RELEVANT CONVERTER
FOR DESIGN WITH CONVERTER AND DISPLAY A MANUAL IS ENCLOSED TO THE RELEVANT CONVERTER AND DISPLAY**

APPLICATION

- For exact remote measurement of temperature of steady and running liquids (gases and fluids), for which the properties of the thermowell of the sensor selected by the customer are suitable; measurement may be realized up to temperature (max. 450°C) and pressure determined by thermowell resistance
- For environment with explosive gaseous atmosphere according to EN 60079-10-1 and explosive atmospheres with combustible dust according to EN 60079-10-2
 - o The sensor may be installed in the thermowell located in zone 0 (20), in zone 1(21) or zone 2(22); thermowell for zone 0 shall comply with the requirements of EN 60079-26 (refer to Figure 7)
 - o Other parts of the sensor (screw-joint, adapter, connecting head) may be located in zone 1(21) or zone 2(22)
 - o Sensor without converter or converter with Ex ia version, when connected to Ex ia circuit according to EN 60079-25 in zone 0, 1, 2, 20, 21 and 22
- In a set with control or diagnostic systems for process monitoring
- In design with converter for transfer of thermoelectric sensor signal to unified output signal 4 to 20 mA or digital signal (converter with HART protocol)
- In design with display to display the value of the measured value
- For the environment, where mechanical resistance is required pursuant to EN 60068-2-6 (class AH2) and seismic capability of the electrical equipment of the safety system of the nuclear power stations pursuant to IEC 980 (MVZ level SL-2)

The sensors are rated products pursuant to the Directive 2014/34/EU, 2014/30/EU of the European Parliament and the Council and Declaration of Conformity **EU -233000** is issued for them.

DESCRIPTION

The sensor consists of a replaceable measuring insert with a flange and a ceramic terminal board or an installed two-wire converter (insulated or non-insulated, even in design Ex ia) and a protective armature consisting of a head and an adapter with a screw-joint for connecting the sensor to the thermowell selected by the customer. The head with measuring insert and outlet form a fixed closure Ex d. It is provided with a lid, which can be screwed, and a cable gland for the connecting wiring. The cable gland (pursuant to the required diameter of the cable) forms optional accessories to the sensor. The terminal board (of the converter) of the sensor is accessible after removing the lid of the head, which is fixed, after being tightened, with a pin against spontaneous releasing. The sensor is provided with an external terminal and an internal terminal on the head for the connection of the grounding wire or wire for mutual interconnection. The sensor with converter is supplied from an external source. The installed converter is pre-set to the required range at the sensor manufacturer. To measure temperature, a defined change of thermoelectric voltage of the sensor in dependence on the change of temperature of the measured environment is used.

TECHNICAL DATA

The sensor dimensions are based on the original ČSN 25 8301. The sensor is designed pursuant to EN61140 as an electrical equipment of protection class III for the application in networks with category of overvoltage in installation II and pollution grade 2 pursuant to EN61010-1; the follow-up (evaluation) device shall comply with Article 6.3 of the said standard.

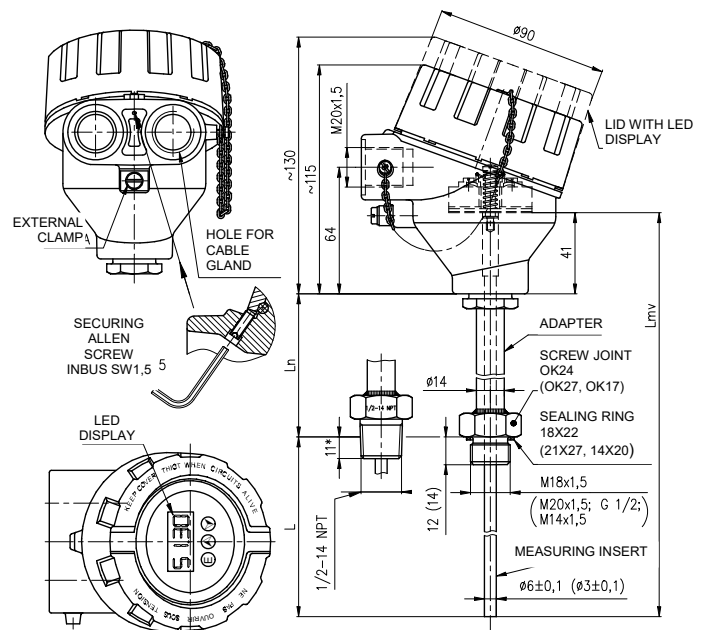

L nominal length
 L_n adapter length
 L_{mv} measuring insert length

Measuring range:

Min. length of adapter L _n [mm]	Measuring range [°C]
135	-70 to 450 *)
65	-70 to 250

*) The upper limit of the measuring range is limited by resistance of the material of the used thermowell; however, it may not exceed 450°C.

If it is ensured in a suitable way that the surface temperature of the part of the sensor located in the dangerous area does not exceed the temperature of the required temperature class (T1...T6), the upper limit of the range of measurement may also be higher (max. 1150°C for thermocouple K, max. 800°C for thermocouple J). Example of installation - refer to Figure 6. Measuring range of the sensor with converter is established by the range of the selected converter.

Design for explosive atmospheres:

Fixed closure pursuant to EN IEC 60079-0 and EN 60079-1,

Ex II 2 G Ex db IIC T1...T6 Gb

(Meaning of designation - see figure 8)

Dust-tight closure pursuant to EN IEC 60079-0 and EN 60079-31:

Ex II 2 D Ex tb IIIC T=T media Db

(Meaning of designation - see figure 8)

Intrinsically safe pursuant to EN IEC 60079-0 and EN 60079-11:

Ex II 1 G Ex ia IIC T5/T6 Ga

(Meaning of designation - see figure 9)

P_i = 500 mW T6 (-60°C ≤ T_a ≤ 68°C)

Intrinsically safe circuit parameters:

only for thermocouple "K" and "J", with measuring insert Ø6

U_i = 60 V U_o = 100 mV

I_i = 100 mA I_o = 50 mA

P_i = 500 mW P_o = 25mW

C_i = 850 pF/m

L_i = 16 µH/m



WARNING

The device must be installed in a housing that meets the degree of protection against intrusion of at least IP 20.



The casing of the measuring insert is not separated from the inner intrinsically safe circuit according to the standard EN 60079-11. This information must be taken into account during installation.

Intrinsically safe version with converter:

according to built-in converter

Electric strength pursuant to EN 61010-1, Article 6.8.3:

500 V eff (only measuring insert without converter or design with insulated converter)

Electric insulation resistance pursuant to EN 61515, Article 5.3.2.4:

min. 1000 M Ω , at ambient temperature 20 \pm 15°C and max. 80% relative humidity, test voltage 500 V DC

Power supply of converter:

DC 24 V from source SELV, e.g. INAP 16 and INAP 901

Other data of the converter: refer to the enclosed manual

Display: LED display to loop 4-20mA

other data refer to enclosed manual

Ingress protection pursuant to EN 60529

IP 68, 1m, 30 min

Operation position:

discretionary, the outlet shall not be situated upwards

Type of operation: continuous

Sensor weight:

with adapter 135 mm 0.93 kg

Used materials:

Stem tube of measuring insert	for thermocouple of type "J"	Steel 1.4541
	for thermocouple of type "K"	INCONEL 600
Adapter		Steel 1.4541
HEAD		Aluminium alloy painted with polyester paint
		Steel 1.4401
Head terminals of terminal board		Brass with Ni surface
Connecting items of sensor		Stainless steel

OPERATION CONDITIONS

The environment is defined by the group of parameters and their severity grades IE 36 pursuant to EN60721-3-3 and the following operation conditions.

Ambient temperature for head and outlet of the sensor:

- for design without converter $-50\text{ }^{\circ}\text{C} \leq T_a \leq 85\text{ }^{\circ}\text{C}$
- for design with converter pursuant to the type of converter (refer to the enclosed converter manual) max. $-50\text{ }^{\circ}\text{C} \leq T_a \leq 75\text{ }^{\circ}\text{C}$
- for design with converter and display pursuant to the type of converter and display (refer to the enclosed converter and display manual) max $-50\text{ }^{\circ}\text{C} \leq T_a \leq 75\text{ }^{\circ}\text{C}$

Maximum surface temperature of the sensor:

it complies with the maximum temperature of the measured medium

Maximum surface temperature for equipment operating in the environment with a threat of explosion of gases, steam and mist pursuant to EN 60079-0 and temperature class of the sensor are determined in dependency on the temperature of measured medium pursuant to the following table:

Temperature class	Maximum surface temperature	Maximum temperature of measured medium
T6	85°C	85°C
T5	100°C	100°C
T4	135°C	135°C
T3	200°C	200°C
T2	300°C	300°C
T1	450°C	450°C

Maximum permitted surface temperature for the equipment operating in the environment with a threat of explosion of dust pursuant to EN 61241-14:

a) Temperature limitation due to occurrence of stirred dust:

$$T_{\max} = 2/3 T_{ci}$$

where T_{ci} is the temperature of ignition of stirred dust

b) Temperature limitation due to occurrence of layers of dust to 5mm thickness: $T_{\max} = T_{5\text{ mm}} - 75\text{ }^{\circ}\text{C}$

where $T_{5\text{ mm}}$ is the temperature of ignition of dust layer 5mm thick

c) Dust layers over 5 mm – refer to EN 61241-14

Maximum permitted surface temperature is defined by the lower value of the values specified above.

Intrinsically safe measuring inserts can be used in intrinsically safe circuits of group II electrical equipment.



WARNING



The user shall guarantee that the maximum surface temperature of any part of the sensor does not exceed the temperatures of ignition of any gas, steam or dust, which can occur, due to external thermal effects.

Vibrations:

Sensor	with converter			without converter		
	100, 160	250, 400	630	100, 160	250, 400	630
Nominal length L [mm]						
Frequency range [Hz]	10 to 500					
Drift amplitude [mm]	0.2	0.15	0.075	0.5	0.2	0.075
Acceleration amplitude [ms ⁻²]	29.4	19.6	9.8	68.7	39.2	9.8

Relative ambient humidity:

- 10 to 100 % with condensation, with upper limit of water content 29 g H₂O/kg of dry air
- For design with converter pursuant to type of converter (refer to enclosed converter manual)
- For design with converter and display (refer to enclosed converter and display manual)

Atmospheric pressure: 70 to 106 kPa

Maximum speed of flow of liquids:

pursuant to parameters of thermowell used by the customer

METROLOGICAL DATA

Sensing probe: measuring thermocouple J (Fe-CuNi) or K (NiCr-NiAl) pursuant to EN 60584-1, \varnothing 6 or \varnothing 3 mm, tolerance class 2 or 1, single with insulated measuring end or double with independent measuring end

Output signal

of the analogue converter (linear with thermoelectric voltage):

4 to 20 mA

of the programmable converter (linear with measured temperature):

4 to 20 mA (+ digital for HART protocol)

Calibration depth of immersion of the measuring insert of the sensor

for temperature points within range -70 to 250°C:

200 mm (min. 160 mm)

for temperature points over 250°C:

300 mm (min. 260 mm)

The distance of flange of the measuring insert from the level of medium in the calibration bath shall be at least 40 mm at temperatures to 250°C and min. 70 mm at temperatures above 250°C.

Temperature response time pursuant to EN 60751 in whirling water (characteristic value):

without thermowell (independent measuring insert)

$\tau_{0.5}$ 4.3 s

with thermowells 99110.....,99111.....,99112..... and 99113... (L = 160)

$\tau_{0.5}$ 85 s

$\tau_{0.9}$ 250 s

with thermowells 99110.....,99111.....,99112..... and 99113... (L = 250, 400, 630)

$\tau_{0.5}$ 53 s

$\tau_{0.9}$ 155 s

with thermowell 991150...(L = 160)

$\tau_{0.5}$ 80 s

$\tau_{0.9}$ 235 s

with thermowell 991170...(L = 160)

$\tau_{0.5}$ 36 s

$\tau_{0.9}$ 100 s

Temperature response time pursuant to EN 60751 in whirling water for measuring insert \varnothing 3 mm (characteristic value):

Without thermowell (independent meas. insert)

$\tau_{0.5}$ 2 s

$\tau_{0.9}$ 4 s

with thermowell 991180...(L = 160)

$\tau_{0.5}$ 20 s

$\tau_{0.9}$ 90 s

DESIGNATION:**Data on label of head**

- Trademark of the manufacturer
- Made in Czech Republic
- Type of the thermoelectric sensor / tolerance class
- Measuring range or adjustable range of the converter
- Product ordering number
- Ingress protection
- Serial number
- Output signal 4 to 20 mA (design with converter)
- Ambient temperature $-40\text{ °C} \leq T_a \leq 70\text{ °C}$
- Designation of non-explosiveness:
 - ⊕ II 2 G Ex db IIC T1...T6 Gb
 - ⊕ II 2 D Ex tb IIC T=T media Db
 - ⊕ II 1 G Ex ia IIC T5/T6 Ga
- EU-Type Examination Certificate number
- Designation of non-explosiveness and EU Type Examination Certificate number (for design with converter Ex ia)
- CE mark 1026

Data on label of measuring insert

- Trademark
- Type of sensor / tolerance class
- Serial number

Data on converter label

- Trademark
- Sensor type
- Pre-set temperature range
- Designation of non-explosiveness and EU-Type Examination Certificate number for design with converter Ex ia
- CE mark with identification number of the notified person (for design with converter Ex ia)

Data on display

- Trademark
- CE mark

DELIVERY

Unless agreed otherwise with the customer, each delivery includes

- Delivery note
- Sensor pursuant to the purchase order
- Sealing ring 21x27 TPD 62-014-91
- ALLEN key 1.5 mm
- Separately ordered accessories; pursuant to the catalogue of, type 991:
 - o Suitable thermowells and nipples
 - o Suitable cable gland. An instruction sheet is delivered with each cable gland
- Optional accessories to sensor with programmable converter
 - o Configuration (parameterization) programme pursuant to the required converter
 - o Communication modem (for serial port RS 232C) pursuant to the required converter
- Accompanying technical documentation in Czech
 - o Product manual
 - o Product quality and completeness certificate, which also serves as the warranty certificate
 - o EU Declaration of Conformity

If it is established in the purchase contract or agreed otherwise, the following documentation can be also delivered with the product

- Calibration sheet (for uncertified calibrated design)
- Test report about the seismic and the vibration qualification
- Copy of EU-Type Examination Certificate pursuant to the Directive No 2014/34/EU for fixed closure and dust-tight closure
- Copy of EU-Type Examination Certificate pursuant to the Directive No 2014/34/EU for Ex ia design

CERTIFICATION

- Non-explosiveness Ex ia, EU-Type Examination Certificate pursuant to the Directive 2014/34/EU FTZÚ 08 ATEX 0199X as amended
- Non-explosiveness Ex ia, EU-Type Examination Certificate pursuant to the Directive 2014/34/EU FTZÚ 21 ATEX 0007X

- Non-explosiveness Ex ia, EU-Type Examination Certificate pursuant to the 2014/34/EU (pursuant to the type of the converter and display)

RELIABILITY

Indicators of reliability in operation conditions and ambient conditions specified herein

- Medium time of operation between failures 96 000 hours (inf. value)
- Expected service life 10 years

CALIBRATION

It is realized pursuant to TPM 3322-94 and in compliance with EN584, usually in three temperature points evenly distributed within the operation range of the sensor or in the points according to the requirement of the customer. Calibration sheets with measured data are issued for calibrated sensors.

PACKING

Both sensors and accessories are delivered in a packing ensuring resistance to the impact of thermal effects and mechanical effects pursuant to controlled packing regulations.

TRANSPORT

The sensors may be transported on conditions corresponding to the set of combinations of classes IE 21 pursuant to EN IEC 60721-3-2 (i.e. by airplanes and trucks, in premises that are ventilated and protected against atmospheric effects).

STORAGE

The products may be stored on conditions corresponding to the set of combinations of classes IE 12 pursuant to EN IEC 60721-3-1, but with ambient temperature from -20 to 70 °C (i.e. in places without control of temperature and humidity, with danger of occurrence of condensation, dropping water and formation of ice, without a special threat of an attack with biological agents, with vibrations of small significance and not situated close to sources of dust and sand).

ORDERING TEMPERATURE SENSORS

The purchase order shall specify

- Name
- Product ordering number
- Ex ia design is ordered using codes JIX, or DUX according to Table 1
- Additional requirements for sensor design pursuant to Table 2
- Request for other documentation pursuant to Table 2
- Measuring range
- If calibration is required and in what temperature points
- If the delivery of a thermowell and a nipple pursuant to the type 991 is required for the sensor as accessories
- If the delivery of gland for output cable pursuant to the type 991 is required for the sensor as accessories
- If optional accessories to the sensor with programmable converter is required
- Request for other documentation according to Article DELIVERY
- Other (special) requirements
- Number of pieces

Behind the ordering number specified pursuant to the above mentioned table, the customer shall identify the required range of measured temperature (i.e. lower and upper temperature limits in $^{\circ}\text{C}$) and, as the case may be, other non-standard required parameters for converter configuration (e.g. indication of sensor tripping, dampening, required designation - tagging etc.).

PURCHASE ORDER EXAMPLE

Standard design:

Thermoelectric temperature sensor Ex d (Ex t) to thermowell ČSN without converter
343 410 211K2/JI
Range -70 to 450°C
6 pcs

Special request:

Thermoelectric temperature sensor Ex d (Ex t) to thermowell ČSN with converter
343 910 212J2/HCF
Nominal length L = 380 mm
Range 0 to 300°C
6 pcs

ORDERING ACCESSORIES

The purchase order shall specify:

- Name
- Ordering number
- Number of pieces

EXAMPLE OF PURCHASE ORDER

Standard design:

1. Cylindrical thermowell screw, non-reduced
991 10 00 33
20 pcs
2. Nipple
991 NVP4 M27 72
6 pcs
3. Cable gland
991 VM 612
5 pcs

Special request:

Cylindrical thermowell screw, non-reduced
991 12 00 99
thermowell material 1.4404
nominal length L = 380 mm
10 pcs

TABLE 1 - DESIGN OF TEMPERATURE SENSORS Ex d (Ex t, Ex i) TO THERMOWELL ČSN - TYPE 343

SPECIFICATION					ORDERING NUMBER																			
					343	x	x	0	x	x	x	x	x	/xxxxxx	/xxx									
Nominal length L [mm]	100	Adapter length L _n [mm]	135	Length of measuring insert L _{mv} [mm]	280	1																		
	160				2																			
	250				3																			
	400				4																			
	630				5																			
	Other (min. 75) *)				9																			
Nominal length L [mm]	100	Adapter length L _n [mm]	65	Length of measuring insert L _{mv} [mm]	210	1																		
	160				2																			
	250				3																			
	400				4																			
	630				5																			
	Other (min. 75) *)				9																			
Adapter length	135mm					1																		
	65 mm *) max. -70 to 250°C					2																		
	Other **) (min. 65 mm)					9																		
Thermowell material	without thermowell						0																	
Connecting thread	M20 x 1.5										2													
	G1/2 *)										3													
	Other *)										9													
Head of the sensor with thread for gland Ex d (Ex t) - overview of glands see Tab.5	Aluminium alloy painted with blue epoxy colour		M20x1.5								1													
	with blue epoxy colour		1/2-14NPT								2													
	Corrosion resistant steel 1.4401		M20x1.5								3													
	1.4401		1/2-14NPT								4													
Tube of measuring insert [mm]	Ø6 ± 0,1																							
	Ø 8 (with limiting bush)																							
	Ø3 ± 0,1 *)																							
Thermocouple	K																				K			
	J																				J			
	Other *)																					9		
Accuracy class	1 *)																					1		
	2																					2		
Design of measuring ends of thermocouple pursuant to Figure 1	Single thermocouple, insulated end																					/JI		
	Double thermocouple, independent end																						/DU	
	Single thermocouple, insulated end	only for TC "K" a "J", with measuring insert ø 6, length of measuring insert L _{mv} 100 – 3025 [mm]																					1	
	Double thermocouple, independent end																						1	

TABLE 2 - DESIGN OF TEMPERATURE SENSORS Ex d (Ex t, Ex i) TO THERMOWELL ČSN - TYPE 343 (continuation)

SPECIFICATION					ORDERING NUMBER												
					343	x	x	0	x	x	x	x	x	x	x	/xxxxxx	/xxx
Converter type	Galvanic separation	Ex ia	NFC	Range [°C]													
					Converter (design of thermocouple measuring ends: single thermocouple, isolated end)												
Analogue linear output signal with thermoelectric voltage	APAQ-HCF			Adjustable range												/HCF	
	APAQ-HCFX		•														/HCFX
Programmable linear output signal with temperature	TH 200	•		Programmable range												/TH200	
	TH 200-ex	•	•													/TH200X	
	IPAQ-H	•															/IPAQH
	IPAQ-HX	•	•														/IPAQHx
	MINIPAQ-HLP																/MINIPAQ
	IPAQ C202																/C202
	IPAQ C202X		•														/C202X
	IPAQ C330				•												/C330
Programmable with HART protocol linear output signal with temperature	IPAQ C330X		•	•												/C330X	
	IPAQ C520	•														/C520	
	IPAQ C520S (**)	•														/C520S	
	IPAQ C520X	•	•													/C520X	
	IPAQ C520XS (**)	•	•													/C520XS	
	IPAQ C530	•		•												/C530	
	IPAQ C530X	•	•	•												/C530X	
	TH 300	•														/TH300	
	TH 300-ex	•	•													/TH300X	
	MESO-H	•														/MESOH	
MESO-HX	•	•													/MESOHX		
248 HA NA	•														/248HANA		
248 HA I1	•	•													/248HA11X		
644 HA NA	•														/644HANA		
644 HA I1	•	•													/644HA11X		
Other *)																/99	
Without converter (for installation of the converter by the customer)																/00	
LED display to loop 4-20 mA (not possible with head from corrosion resistant steel) (only with converter INPAL 420, APAQ-HRF, TH 100, MINIPAQ-HLP)					LPI-02											/LD	

Standard design

- *) Only as a special request after an agreement with the manufacturer
- **) In case of adapter length below 135 mm (minimum 65 mm), the temperature range is decreased to -70 to 250 °C.
- ***) Functional safety SIL2

TABLE 3 – ADDITIONAL REQUIREMENT FOR DESIGN OF TEMPERATURE SENSORS Ex d (Ex t) TO THERMOWELL, TYPE 335

SPECIFICATIONS			CODE
CALIBRATION	NUMBER OF CALIBRATION POINTS	CALIBRATION RANGE	
Calibration by TPM 3342-94, define calibration points	3	0 to 800 °C	/Q4
	3	0 to 1100 °C	/Q42
	Other	0 to 1100 °C	/Q9
REQUIREMENT FOR OTHER DOCUMENTATION		USE	
EU Declaration of Conformity		for design with converter	/EU
Copy of EU-Type Examination Certificate acc to the 2014/34/EU (ATEX)		for Ex ia design	/Exi
Copy of the Inspection Certificate 3.1 acc to EN 10204 for material of tube with the heat number			/3.1
Declaration of Conformity with purchase order 2.1 pursuant to EN 10204			/2.1

Specify the code behind ordering number. Define calibration points for codes Q4, Q42 a Q9.

TABLE 4 - THERMOWELLS RECOMMENDED FOR ASSEMBLY OF TEMPERATURE SENSORS TO THERMOWELL - TYPE 991

SPECIFICATIONS							ORDERING NUMBER					
							991	xx	x	x	x	x
Cylindrical thermowell	PN 160	Screwing, internal thread M27x2	Non-reduced (ON 02 7210)				Ø9		10	0		
			Reduced				Ø9/Ø6		11	0		
		welding external Ø 27 mm	Non-reduced (ON 02 7212)				Ø9		12			
			Reduced				Ø9/Ø6		13			
Conical thermowell	PN 250	Screwing external thread M33x2	Bore [mm]	For high speeds of flow Non-reduced (ON 02 7215)		Ø9 only L = 160, 250 and 400 only sensor thread M20×1,5		15	0	0	2	
				For high parameters of operation liquid, reduced (ON 02 7217)			Ø9/Ø6 only L = 160, 250 a 400 only sensor thread M20×1,5		17	0	0	2
				For high parameters of operation liquid, reduced (ON 02 7218)				Ø9/Ø7/Ø3,2 only L = 160 only sensor thread M20×1,5		18	0	0
Fast-response thermowell	PN 250	Welding	For high parameters of operation liquid and high speeds of flow		Ø7/Ø3,2 only L = 160, 250 a 400 only sensor thread M20×1,5 only from steel 1.4541		19		0	0	3	
Sensor thread	M20x1,5								0			
	G1/2 Only cylindrical thermowells								G			
Flange	Without flange									0		
	With flange *) Only cylindrical welding thermowells									F		
Material of immersion part of thermowell	1.0577 **) 15 128 1.4541 *****) 1.4571 **) *****) 1.4903 **) Other *)	For zone 0	no	surface treatment	preservation with grease – oil	maximum operation temperature [°C]	400				1	
							550				2	
							550 (650)***)				3	
							500				4	
							620				5	
							pursuant to material				9	
Nominal length L [mm]	100 Only cylindrical thermowells										1	
	160										2	
	250										3	
	400										4	
	630 Only cylindrical thermowells										5	
	Other *)	max. 3000		For thermowells with codes		10x0, 11x0, 12xx, 13xx						
		max. 1200				1500 a 1700						
max. 500		1800 a 1900										

*) Only as a special request after an agreement with the manufacturer
 **) Only for cone thermowells with codes 1500 and 1700
 ***) Maximum operation temperature 650°C only for thermowells with code 1700 and 1800
 *****) For zone 0 corrosion resistant thermowell shall be used (pursuant to EN 60079-26)
 *****) thermowells of these materials are suitable for contact with food

TABLE 5 - ACCESSORIES - OVERVIEW OF DESIGN OF RECOMMENDED NIPPLES FOR SCREW-IN THERMOWELLS , TYPE 991

SPECIFICATION							ORDERING NUMBER				
							991	xxx	x	xxx	xx
Shape	direct							NVP			
	oblique (chamfer 45°)							NVS			
Internal thread	M27 × 2		PN	160 (40) **)			4	M27			
	M33 × 2			250			5	M33			
	Other *)						9				
Material	1.0308 or 1.0122		surface treatment	conservation by fat - by oil		maximum operation temperature [°C]	300 (only PN 40)		M27	13	
	1.0577			-			400		M33	15	
	15 128			-			550		M27	51	
	1.4541			-			550			72	
	other *)			pursuant to material			pursuant to material				99

*) only as a special requirement after an agreement with the manufacturer

TABLE 6 - OVERVIEW OF DESIGNS AND ORDERING OF CABLE GLANDS Ex d (Ex t) BRASS – TYPE 991

SPECIFICATION							Ordering number		
							991	xx	xxx
Gland Ex d (Ex t) brass		Cable clamp (clamping module)							
Size	Wrench		Size	Dimension		Thread	Torque of gland body	For cable Ø [mm]	
	A	B		C	Ds				
No. 4	OK 17	OK 24	No. 4	5	20	M20×1.5	30 - 35 Nm	4,5-8.5	VM 458
No. 5	OK 19		No. 5	5	22			7-11	VM 711
No. 6	OK 24		No. 6	6	27.5			10-16	VM 016
No. 4	OK 17		No. 4	5	20	1/2-14 NPT	25 - 30 Nm	4,5-8.5	VK 458
No. 5	OK 19		No. 5	5	22			7-11	VK 711
No. 6	OK 24		No. 6	6	27.5			10-15.5	VK 015

TABLE 7 –OVERVIEW OF SEALING RINGS TYPE 991 SUPPLIED TO TEMPERATURE SENSORS

EXTERNAL FIXING THREAD OF TEMPERATURE SENSORS	SEALING RING			
	DIMENSION [mm] Ød x ØD x t	MATERIAL	NUMBER	ORDERING NUMBER
M20 x 1,5 G1/2	21x27x2	copper thermally insulating insert		991 TK 21

The sealing ring is supplied to each sensor by default. The sealing ring can also be ordered separately using ordering number

INSTALLATION AND CONNECTION

SENSOR INSTALLATION

Install the sensors by screwing into the relevant thermowell screwed into the nipple on the piping (technological equipment) or welded into the piping wall. Before the installation, put on the enclosed sealing ring in advance. During the installation, torque of 70 Nm is recommended. A proposal of securing the thermowell of the temperature sensor Ex d for nominal lengths exceeding 630 m is in Figure 2; examples of installation of direct and angular nipples are in Figure 3.

With respect to maintaining metrological properties and the longest possible service life, it is not recommended to install the sensors in places with high turbulence of the medium, which is caused e.g. by a rapid transition from a small diameter of the piping to a larger one (when failing to comply with the required shape and dimensions of diffuser behind the flow meter), etc. Recommended distance of the temperature sensor from the installation flange of the flow meter is min. 1 m.



WARNING



The temperature sensor may be install to the thermowell located in the zone 0 (20), zone 1 (1) or zone 2 (22), thermowell for zone 0 must be in accordance with the EN 60079-26. (See Figure 7).

The other parts of the sensor (fitting, adapter, connecting head) may be located in zone 1 (21) or zone 2 (22).

When installing sensor in the thermowell located in zone 20, a pre-fuse with the following parameters must be used in the converter encoder circuit: Ceramic, quick break (F), short circuit resistance 1500A (H), e.g. ceramic tube fuse Ø5 x 20 mm, F100mA.

Distance of the fixed closure Ex d IIC from close structures or between the closures shall be at least 40 mm.

The temperature sensor with a paint finish must be installed in an explosive atmosphere with dust so as to avoid the occurrence of creep discharges

INSTALLATION OF CABLE GLAND

Only a certified cable gland shall be used to secure the fixed closure (dust-tight closure) Ex d IIC (Ex tb IIIC) with IP 68 protection (see accessories type 991 or another similar gland). For temperature sensors with converter, a barrier cable gland must be used in zone 1 of the IIC gas gauge, or an Ex ia converter.

The gland shall be tightened in the sensor head in the prescribed way.

Torque of outlet body:

- | | | |
|----|------------------------------------|-----------|
| a) | for outlet with thread 1/2 - 14NPT | 25 – 30Nm |
| b) | for outlet with thread M20x1.5 | 30 – 35Nm |

Installation of the cable in the outlet, its sealing and securing against pull-out shall be realized pursuant to the instruction sheet of the outlet supplier.



WARNING

Do not use other sealing rings in the outlet than the original ones delivered by the manufacturer. Do not change artificially the outer diameter of the cable e.g. by winding it around with electrical insulating tapes.

ELECTRICAL CONNECTION

The electrical connection may be only realized by qualified workers.

The sensor installation in conditions with explosive gaseous atmosphere or flammable dust shall comply with the requirements of EN 60079-14.

The terminal board of the sensor (converter) is accessible after unscrewing the lid of the head.

Connect the evaluation devices to the sensor with a cable with double insulation; internal wires with Cu core (sensor with

converter) or compensation wiring (sensor without converter) 0.5 to 1.5 mm². Sensors without converter connect with unarmoured shielded compensation or double insulated thermocouple wiring with cross section 0.5 to 1.5 mm² and outer diameter according to cable gland.

Seal the cable in the gland by prescribed tightening of the closing nut pursuant to instruction sheet of the gland Then secure it with clamp against pull-out.



WARNING



The connecting cable must have a casing of thermoplastic, thermoset or elastomeric materials. The cable must be circular and compact, the filler or shell must be extruded and the filler material, if used, must be non-absorbent. The length of the connecting cable must be at least min. 3 m. Temperature resistance of the cable shall comply with the ambient temperature!

The cable insulation shall have chemical and mechanical resistance in compliance with the conditions, in which the cable will be installed. It is recommended supporting the cable along its length between the sensor and the follow-up device. In the environment with interfering signals, use shielded cable in the power supply circuit. Shielding may be only grounded (earthed) in one point. The cable should not be placed together with power cables.

In case of the sensor with HART protocol converter, the maximum length of wiring is defined by the arrangement of wires of the connecting cable. The total length of wiring may be up to 1500 m. It requires a twisted two-wire with shared shielding with the cross section of the core min. 0.5 mm². Recommended HART communicator, model 275, is connected to the supply loop of the converter pursuant to Figure 5. To achieve reliable communication, resistor 250 Ω shall be introduced in the circuit of the output loop.



WARNING



Programmable converter may not be connected to a computer or a HART communicator if the converter is located in explosive environment.

The surface temperature of the converter must not exceed the maximum surface temperature for a given temperature class.

For installation in a dangerous area, a connection is required (placing on the same potential). You can use the terminals on the sensor head to do this.

The sensor need not be connected separately to the interconnection system if it is firmly attached and metallically connected to the components or piping that is connected to the interconnection system.

SENSOR HEAD WITH TERMINALS

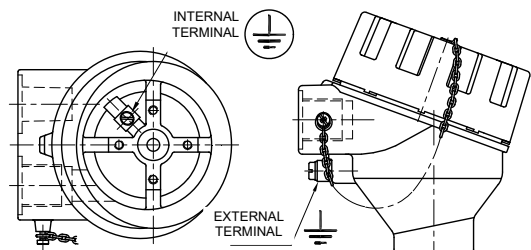

Maximum cross-section of wire for connection to external and internal terminals:

Internal terminal: stranded wire 1.5 mm², full wire 2.5 mm²



External terminal: stranded wire 4.0 mm², full wire 6.0 mm²

If stranded wires are used for the interconnection, they shall be protected against fraying with pressing hollow.



CLOSING HEAD OF FIXED CLOSURE Ex d

After electrical connection of the sensor, the lid of the head shall be fully tightened by hand, then released slightly to

ensure matching with the closest groove against the securing screw and fixed by this screw against releasing. If the lid of the sensor is not tightened and secured by the above mentioned screw, the sensor does not comply with the requirements of fixed closure Ex d.

 **WARNING:** 
Power supply of the sensor may not be connected before closing the fixed closure!

SENSOR INSTALLATION WITHOUT CONVERTER AND SENSOR WITH CONVERTER Ex ia TO ZONE 0 (20)

 **WARNING:** 
The user is responsible for ensuring that during operation in zone 0 is between the sensor head from an aluminium alloy and other equipment preclude any risk of ignition due to impact and friction.

The sensor without converter can be used, in case of the installation pursuant to EN 60079-11, Art. 5.7 in the intrinsically safe circuit Ex ia according to EN 60079-25), as a simple equipment. For simple equipment, the maximum temperature can be determined from the value of the P₀ of the follower and the temperature class is determined.

Sensor with converter Ex ia can be used while adhering to the Ex ia parameters of the converter shall be complied with pursuant to the enclosed converter manual.

In intrinsically safe circuits, only insulated cables that are capable of withstanding an electrical strength test with a voltage equal to twice the voltage in the intrinsically safe circuit or 500 V eff (DC 750 V) must be used, with a larger value being taken.



When installing intrinsically safe circuits, including cables, do not exceed the maximum allowable inductance, capacity or ratio LiR and surface temperature. Permissible values are determined from the documentation of the connecting device or label. Place follow-up equipment out of the danger area. An intrinsically safe source approved for supplying intrinsically safe devices in accordance with EN 60079-11 must always be used.

The shield of the intrinsically safe circuit cable must be grounded in the same place as the intrinsically safe circuit, the connection must be outside the dangerous area.

If the intrinsically safe circuit is isolated from the ground, the shield must be connected in one place to the protective interconnection system. This can be using the terminals on the sensor head.

COMMISSIONING

After the sensor installation, including closing the fixed closure, and connection of the follow-up (evaluation) device to the supply voltage (and the settlement period of the converter), the equipment is prepared for operation.



 **WARNING** 
After installation must be require initial inspection equipment and installations according to EN 60079-17

OPERATION AND MAINTENANCE

The sensor does not require any operation, maintenance and follow-up periodical revisions or permanent supervision of expert staff shall be carried out pursuant to EN 60079-17.

 **WARNING** 
Any intervention into the sensor and its structure will result in a change of properties and can result in an explosion!

SENSOR UNINSTALLATION

 **WARNING** 
Warning: Temperature sensor is in design Ex and must be disconnected from the power supply source before opening the lid of the head and releasing the cable gland in the explosive environment!

Release the securing screw of the lid with ALLEN key 1.5 mm (a part of accessories). The terminal board of the sensor (converter) is accessible after unscrewing the lid of the head. Measuring insert of the sensor can be replaced and is uninstalled from the head after disconnecting the cable by releasing two screws.

Before a complete uninstallation of the sensor, the wire for mutual interconnection shall be released from the external terminal on the sensor.

Disconnect the connecting cable from the terminal board, then release it from the clamp on the outlet and from closing nut of the outlet. Unscrew the sensor from the thermowell; torque for releasing is approx. 70 Nm. While releasing the screw-joint of the sensor, the thermowell may never be released.

SPARE PARTS

Spare parts shall be delivered by the manufacturer. Relevant measuring inserts can be ordered pursuant to the following table:

SPECIFICATIONS		ORDERING NUMBER					
		MV340	/xxx/	x	x	x	/xxxx
Length of measuring insert [mm]		Pursuant to tab. 1					
Tube of measuring insert [mm]	6 ± 0,1			1			
	Ø 8mm (with limiting bush)			2			
	3 ± 0,1			3			
Sensing probe	Thermocouple K				K		
	Thermocouple J				J		
Accuracy class	1					1	
	2					2	
Connection of the terminal board and design of measuring ends of thermocouple or converter	Single thermocouple, insulated end						/JI
							/JIX *)
	Double thermocouple, independent end						/DU
							/DUX *)
Converter pursuant to tab. 1							/converter

*) Ex ia design(only with measuring insert ø 6, length of measuring insert L_{mv} 100 – 3025 [mm])

EXAMPLE OF PURCHASE ORDER OF MEASURING INSERT

Thermoelectric measuring insert without converter
 340 /430/ 1K2/JI
 6 pcs

To order the certified measuring inserts, specify the code according to Table 2 – Additional requirements – behind the ordering number.

The measuring inserts are marked according to Article DESIGNATION. Designation is completed with the ordering number.

Each delivery includes

- Delivery note
- Measuring insert pursuant to the purchase order
- Optional accessories to the measuring insert with a programmable converter
 - o Configuration program according to the required converter
 - o Communication modem (for serial port RS 232C) according to the required converter
- Accompanying technical documentation in Czech
 - o Product manual
 - o Product quality and completeness certificate, which also serves as the warranty certificate
 - o EU Declaration of Conformity (for Ex ia design)

If it is established in the purchase contract or agreed otherwise, the following documentation can be also delivered with the product

- Calibration sheet (for calibrated design)
- EU Declaration of Conformity (for design with converter)

- Copy of EU-Type Examination Certificate pursuant to the Directive No 2014/34/EU for Ex ia design

WARRANTY

The warranty period is 24 months from the receiving of the product by the customer, unless established otherwise in the contract. Rejection of defects shall be enforced in writing at the manufacturer within the warranty period. The rejecting side shall identify the product name, ordering and manufacturing numbers, date of issue and number of the delivery note, clear description of the occurring defect and the subject of the claim. If the rejecting side is invited to send the device for repair, it shall do so in the original package of the manufacturer and/or in another package ensuring safe transport. The warranty shall not apply to defects caused by unauthorized intervention into the device, its forced mechanical damage or failure to comply with operation conditions of the product and the product manual.

REPAIRS

The sensors shall be repaired by the manufacturer. They shall be sent for repair in the original or equal package without accessories.

DISABLING AND LIQUIDATION

The product and its package do not include any parts that could impact the environment. The products that are withdrawn from operation, including their packages (with the exception of products marked as electrical equipment for the purposes of return withdrawal and separate salvage of electrical waste), may be disposed of to sorted or unsorted waste pursuant to the type of waste. The manufacturer realizes free return withdrawal of marked electrical equipment (from 13.8.2005) from the consumer and points out the danger connected with their illegal disposal. The package of the sensor can be recycled completely. Metal parts of the products are recycled, non-recyclable plastic materials and electrical waste shall be disposed of in accordance with applicable legislation.

FIGURE 1 - DESIGN OF MEASURING ENDS OF JACKETED THERMOCOUPLES (SCHEMATIC ILLUSTRATION)

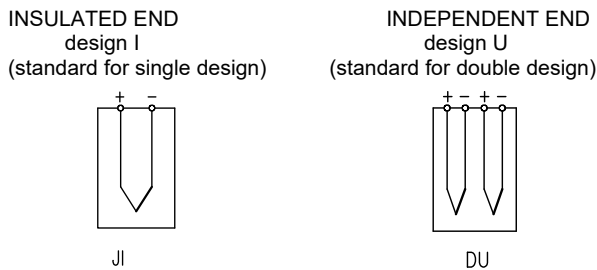
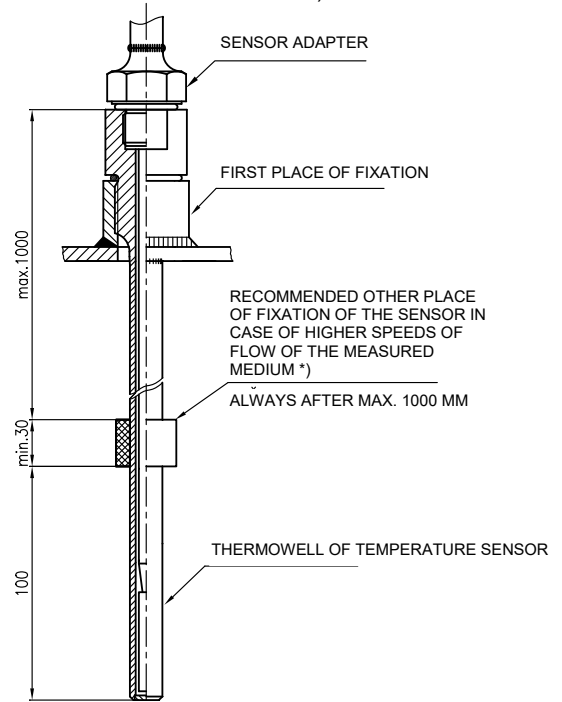
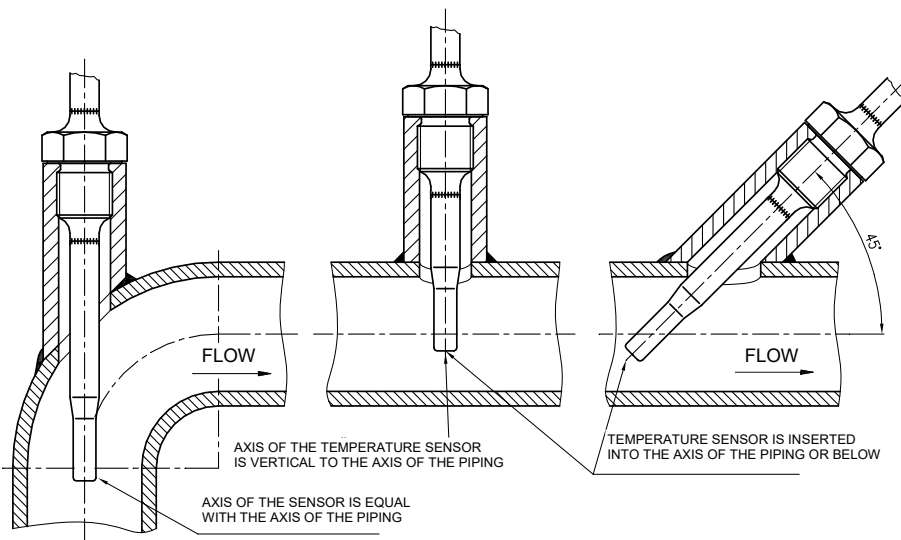

FIGURE 2 - PROPOSAL OF SECURING THERMOWELL OF TEMPERATURE SENSORS Ex d
(for nominal lengths exceeding 630 mm)
Prescribed thermowells of type 991 (pursuant to ON 02 7210, ON 02 7212, ON 02 7215 or ON 02 7217) shall be used.



*) In case of flow of the measured medium, the thermowells are stressed with dynamic effects of the flowing medium and this stress depends on the speed of flow, physical properties of the measured medium and immersion length of the thermowell. If the occurrence of such dynamic effects can be expected, it is recommended to realize further fixation of the sensor thermowell pursuant to the above mentioned proposal.

FIGURE 3 – EXAMPLES OF INSTALLATION OF DIRECT AND OBLIQUE NIPPLES PURSUANT TO EN1434-2



- ! WARNING**
- When using the sensor with an oblique nipple, locate the sensor with thermowell at an angle against the direction of flow.
 - The sensor may not touch the opposite side of the piping.
 - It is also advantageous to use the temperature sensors in the piping elbow. In such a case, locate the sensor with the thermowell against the direction of flow so that the measured medium flows around evenly.

FIGURE 4 - SCHEME OF CONNECTION OF TEMPERATURE SENSORS

SCHEME OF CONNECTION WITHOUT CONVERTER

with single thermocouple

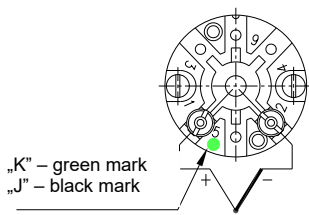

with double thermocouple

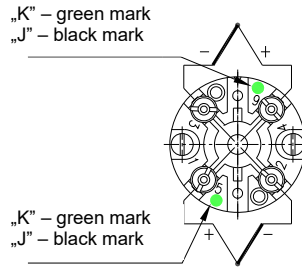

SCHEME OF CONNECTION WITH CONVERTER AND DISPLAY

with converter

with converter with HART protocol

with converter Ex ia

with converter Ex ia with HART protocol

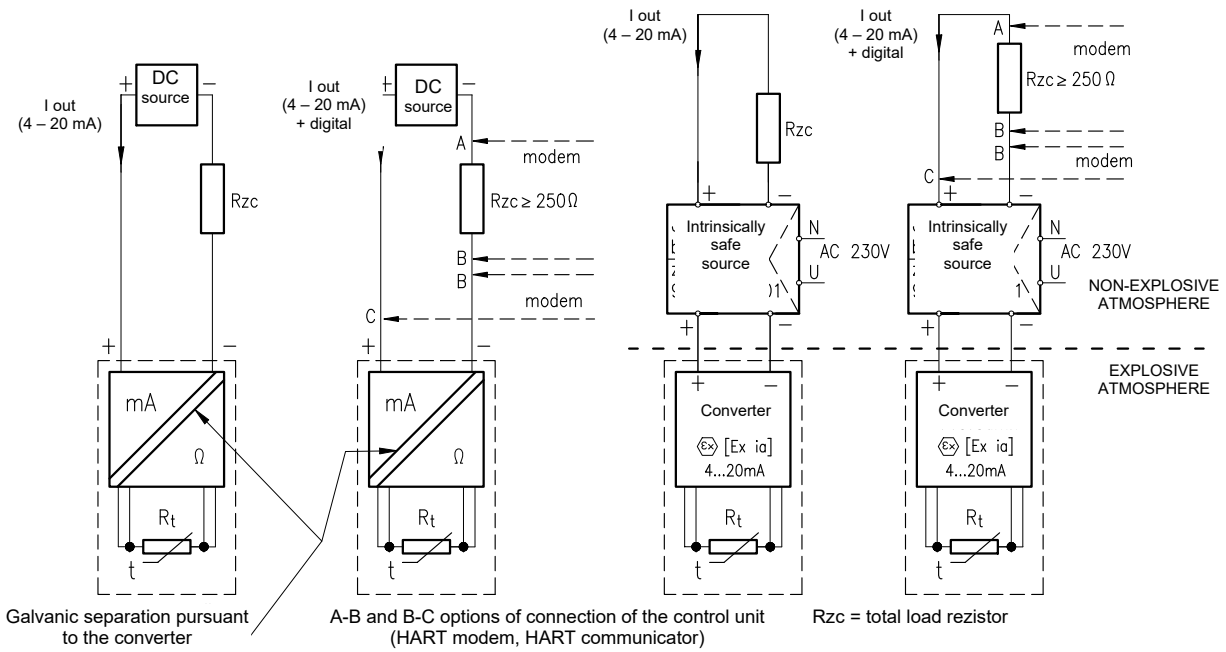

FIGURE 5 - EXAMPLE OF OPERATION CONNECTION OF TEMPERATURE SENSOR WITH CONVERTER IN LOOP 4 - 20 mA SENSOR

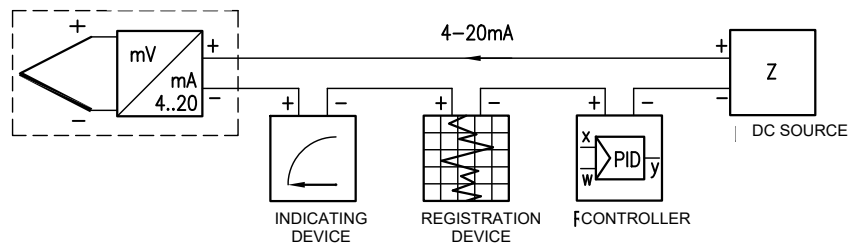

FIGURE 6 – EXAMPLE OF INSTALLATION OF TEMPERATURE SENSORS Ex d TO THERMOWELL ČSN
(in case a higher limit of the measurement range is required on a level exceeding the required temperature class)

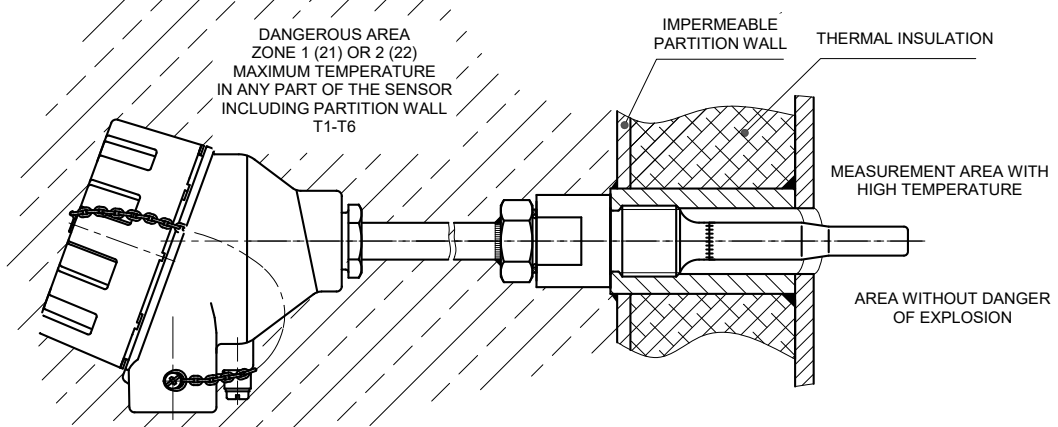

FIGURE 7 – THERMOWELL FOR SENSOR TEMPERATURE Ex d FOR ZONE 0 (pursuant to EN 60079-26)

Thermowell that is used in the function of a partition wall between the zones 1 or 2 and zone 0 shall be made of a corrosion resistant metal and with wall thickness $t \geq 1$ mm

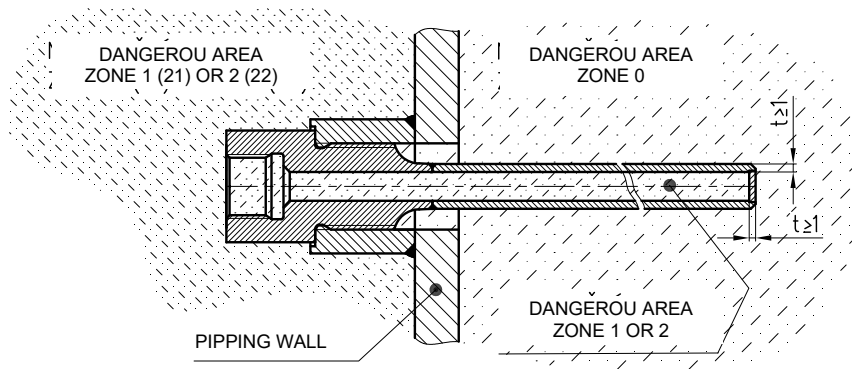

FIGURE 8 – MARK OF NON-EXPLOSIVENESS

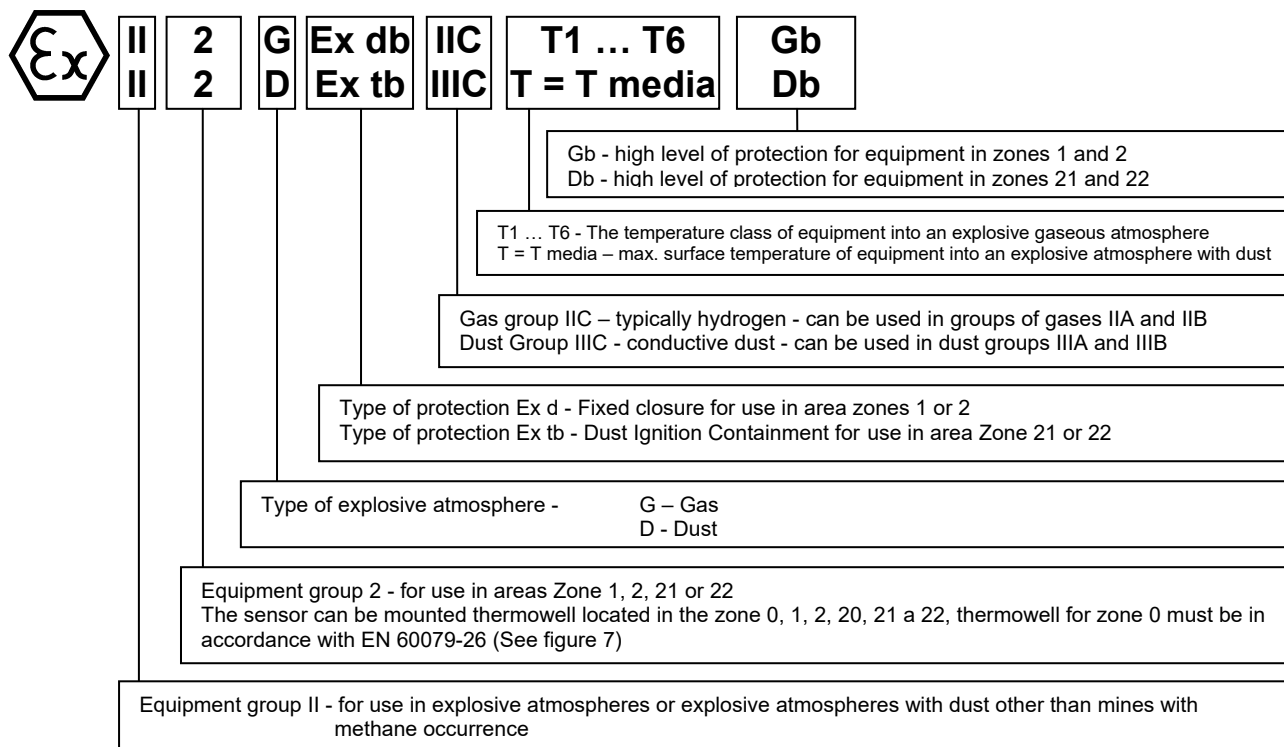
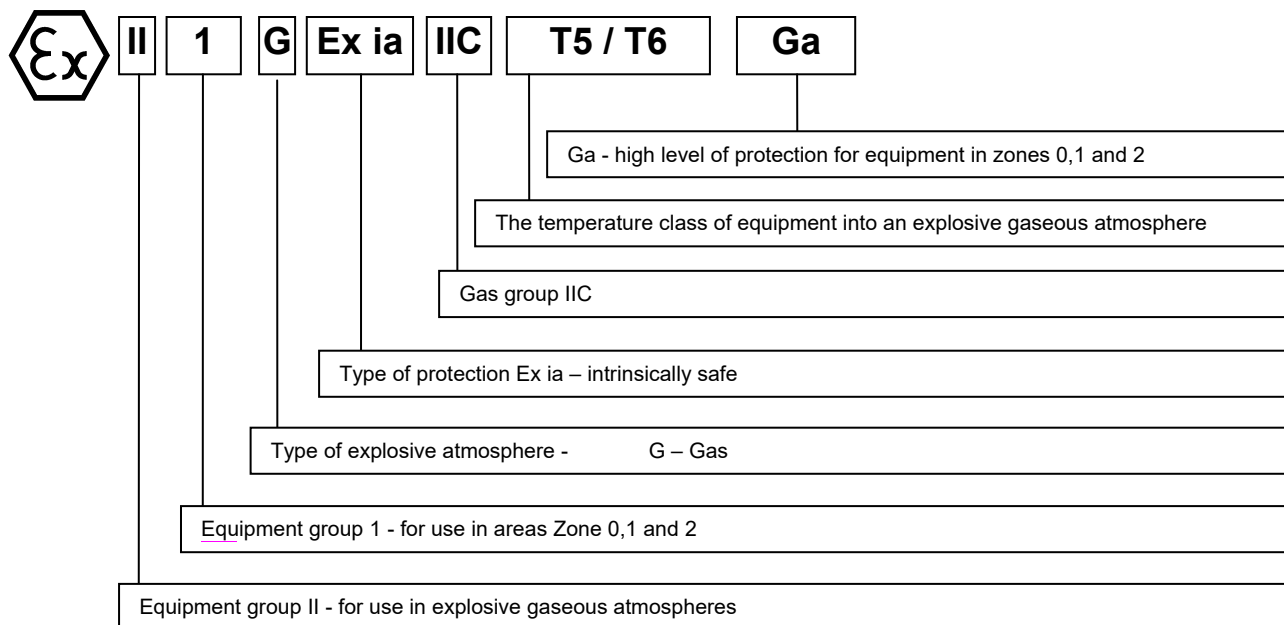

FIGURE 9 - INTRINSICALLY SAFE MARKING





NOVÁ PAKA

ZPA Nová Paka, a.s.
Pražská 470
509 01 Nová Paka

tel.: spojovatel: 493 761 111
e-mail: obchod@zpanp.cz
www.zpanp.cz



bankovní spojení: ČSOB HK
číslo účtu: 271 992 523/300

IČO: 46 50 48 26
DIČ: CZ46504826

April 2021
© ZPA Nová Paka, a.s.