



PRODUCT MANUAL

Thermoelectric rod temperature sensor Ex d (Ex t) with metal or ceramic protective tube without converter or with converter type series 350 type 352

FOR DESIGNS WITH CONVERTER A MANUAL IS ENCLOSED TO THE RELEVANT CONVERTER
FOR DESIGN WITH CONVERTER AND DISPLAY A MANUAL IS ENCLOSED TO THE RELEVANT CONVERTER AND DISPLAY

APPLICATION

- For remote measurement of temperature of gases, for which the properties of the material of the protective tube are suitable (e.g. in furnaces)
- For environment with explosive gaseous atmosphere according to EN 60079-10-1 and explosive atmospheres with combustible dust according to EN 60079-10-2
 - o Thermowell of the sensor may be installed in Zone 0(20), Zone 1(21) or Zone 2(22)
 - o Other parts of the sensor (screw union, adapter, connecting head) may be located in Zone 1(21) or Zone 2(22)
 - o In case of application of the converter Ex ia or connection to Ex ia circuit according to EN 60079-25, the sensor may be used in Zone 0 (20), 1 (21) and 2 (22)
- In a set with control or diagnostic systems for process monitoring
- In design with converter to convert signal of the resistance sensor to unified output signal 4 to 20 mA or digital signal (converter with HART protocol)
- In design with display to display the value of the measured value
- For the environment, where mechanical resistance is required pursuant to EN 60068-2-6 (class AH2) and seismic capability of the electrical equipment of the safety system of the nuclear power stations pursuant to IEC 980 (MVZ level SL-2)

The sensors are rated products pursuant to the Directive, 2014/30/EU of the European Parliament and the Council and EU Declaration of Conformity **EU -252000** is issued for them.

DESCRIPTION

The sensor consists of a replaceable measuring insert with a flange and a ceramic terminal board or installed two-wire converter (insulated or un-insulated, also in design Ex ia) and protective armature consisting of a head and a protective tube. The head with a measuring insert and gland form the fixed closure Ex d. It is provided with a screwing lid and cable gland for connecting wiring. The cable gland (pursuant to the required cable diameter) forms optional accessories of the sensor. The terminal board (of the converter) of the sensor is accessible after unscrewing the lid of the head, which shall be fixed after tightening with a screw against spontaneous release. On the head, the sensor is provided with an external terminal for connection of the grounding wire or wire for mutual interconnection.

The sensor with converter is supplied from an external source. The installed converter is pre-set to the required range at the sensor manufacturer.

To measure temperature, a defined change of thermoelectric voltage of the sensor in dependence on the change of temperature of the measured environment is used.

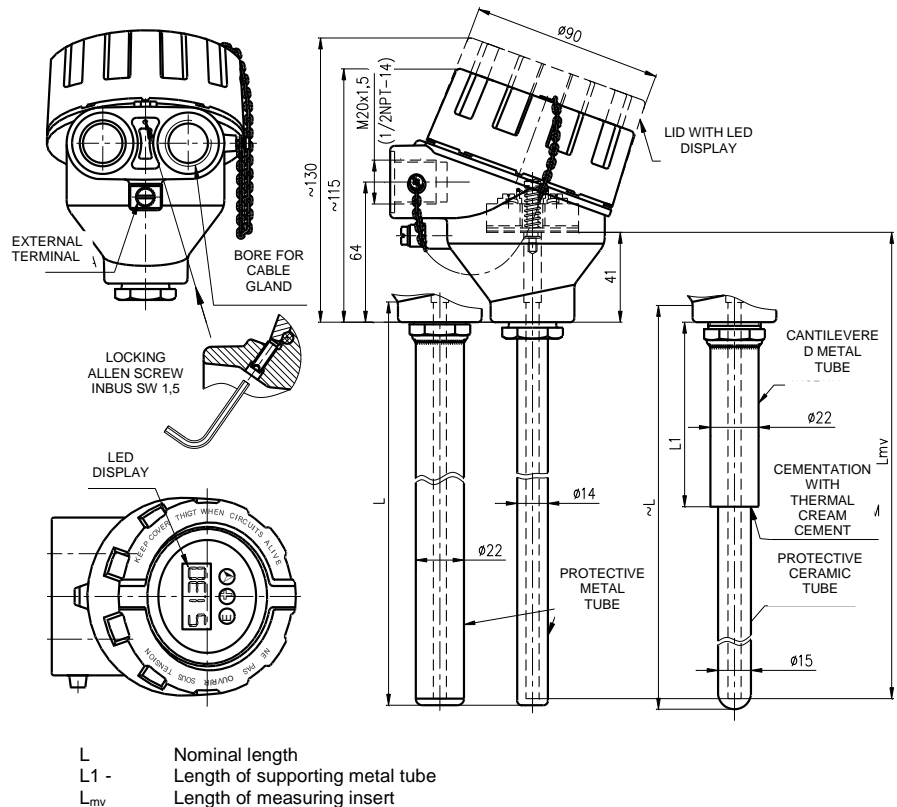

TECHNICAL DATA

The sensor dimensions are based on DIN 43772 and original ČSN 25 8301. The sensor is designed pursuant to EN 61140 ed.2 as an electrical equipment of protection class III for the application in networks with category of overvoltage in installation II and pollution grade 2 pursuant to EN 61010-1; the follow-up (evaluation) device shall comply with Article 6.3 of the said standard.

Measuring range: -70 to 450 °C

The upper limit of the measuring range is limited by resistance of the material of the used protective tube; however, it may not exceed 450°C. If it is ensured by a suitable way of installation that the surface temperature of a part of the sensor located in the explosive area does not exceed the temperature of the required temperature class (T1÷T6), the upper limit of the measuring range may be even higher (max. 1150°C for thermocouple K, max. 800°C for thermocouple J, for another type of thermocouple, the upper limit of the measurement range of the thermocouple is given of resistance this thermocouple). Examples of installation - refer to Figure 1.

Measuring range of the sensor with converter is established by the range of the selected converter.

Design for explosive atmospheres with metal protective tube:

Fixed closure pursuant to EN 60079-0 and EN 60079-1,

⊕ II 1/2 G Ex da/db IIC T1...T6 Ga/Gb

(Meaning of designation - refer to Figure 5)

Dust-tight closure pursuant to EN 60079-0 and EN 60079-31:

⊕ II 1/2 D Ex ta/tb IIC T=T media Da/Db

(Meaning of designation - refer to Figure 5)

Design for explosive atmospheres with ceramic protective tube:

Fixed closure pursuant to EN 60079-0 and EN 60079-1,

⊕ II 2 G Ex db IIC T1...T6 Gb

(Meaning of designation - refer to Figure 5)

Dust-tight closure pursuant to EN 60079-0 and EN 60079-31:

⊕ II 2 D Ex tb IIC T=T media Db

(Meaning of designation - refer to Figure 5)

Intrinsically safe version with converter:
according to built-in converter

Electric strength pursuant to EN 61010-1, Article 6.8.3:
500 V eff (only measuring insert without converter or design with insulated converter)

Electric insulation resistance pursuant to EN 61515, Article 5.3.2.4:
min. 1000 MΩ, at ambient temperature 20±15°C and max. 80% relative humidity, test voltage 500 V DC

Power supply of converter:
DC 24 V from source SELV, e.g. INAP 16 and INAP 901

Other data of the converter: refer to the enclosed manual

Display: LED display to loop 4-20mA
other data refer to enclosed manual

Ingress protection pursuant to EN 60529:
sensor with protective tube

- metal IP 68, 1m, 30 min
- ceramic IP 68, 1m, 30 min/ IP 60 (IP 68 – head of sensor, IP 60 – protective tube)

Operation position:
discretionary, the gland shall not be situated upwards

Type of operation: continuous

Sensor weight:

nominal length L	350 mm approx. 1.06 kg
	500 mm approx. 1.20 kg
	710 mm approx. 1.38 kg
	800 mm approx. 1.46 kg
	1000 mm approx. 1.64 kg
	1400 mm approx. 1.99 kg
	1600 mm approx. 2.17 kg
	2000 mm approx. 2.52 kg

Used materials:

Protective tube	Steel	1.4541
		1.4749
		1.4845 or 1.4841
gas-tight ceramics	LUNIT 73 (content approx. 60 % Al ₂ O ₃) corresponds to a subgroup C 610 pursuant to EN 60672-3)	
	LUXAL 203 (content min. 99,5 % Al ₂ O ₃) corresponds to a subgroup C 799 pursuant to EN 60672-3)	
Tube of measuring insert	for thermocouple of type "J"	Steel 1.4541
	for thermocouple of type "K"	INCONEL 600
Cantilevered metal tube for ceramic tube	Steel 1.4541	
Head	Aluminium alloy painted with polyester paint	
	Steel 1.4401	
Head terminals of terminal board	Brass with Ni surface	
Connecting items of sensor	Stainless steel	

OPERATION CONDITIONS

The environment is defined by the group of parameters and their severity grades IE 36 pursuant to EN 60721-3-3 and the following operation conditions.

Ambient temperature for head and gland of the sensor:

- for design without converter -50 °C ≤ Ta ≤ 85 °C
- for design with converter pursuant to the type of converter (refer to the enclosed converter manual) max. -50 °C ≤ Ta ≤ 75 °C
- for design with converter and display pursuant to the type of converter and display (refer to the enclosed converter and display manual) max -50 °C ≤ Ta ≤ 75 °C

Maximum surface temperature of the sensor:
it complies with the maximum temperature of the measured medium

Maximum surface temperature for equipment operating in the environment with a threat of explosion of gases, steam and mist pursuant to EN 60079-0 and temperature class of the sensor are determined in dependency on the temperature of measured medium pursuant to the following table:

Temperature class	Maximum surface temperature	Maximum temperature of measured medium
T6	85°C	85°C
T5	100°C	100°C
T4	135°C	135°C
T3	200°C	200°C
T2	300°C	300°C
T1	450°C	450°C

Maximum permitted surface temperature for the equipment operating in the environment with a threat of explosion of dust pursuant to EN 61241-14:

- a) Temperature limitation due to occurrence of stirred dust:
 $T_{max} = 2/3 T_{ci}$
where T_{ci} is the temperature of ignition of stirred dust
- b) Temperature limitation due to occurrence of layers of dust to 5mm thickness:
 $T_{max} = T_{5mm} - 75 °C$
where T_{5mm} is the temperature of ignition of dust layer 5mm thick
- c) Dust layers over 5 mm – refer to EN 61241-14

Maximum permitted surface temperature is defined by the lower value of the values specified above.



WARNING

The user shall guarantee that the maximum surface temperature of any part of the sensor does not exceed the temperatures of ignition of any gas, steam or dust, which can occur, due to external thermal effects.



Relative ambient humidity:

- 10 to 100 % with condensation, with upper limit of water content 29 g H₂O/kg of dry air
- For design with converter pursuant to type of converter (refer to enclosed converter manual)
- For design with converter and display (refer to enclosed converter and display manual)

Atmospheric pressure: 70 to 106 kPa

Maximum speed of flow of gas medium: 2 m/s

Vibrations:

Nominal length L[mm]	350 to 1000	1400 to 2000
Frequency range [Hz]	10 to 55	
Drift amplitude [mm]	0.15	0.075
Acceleration amplitude [ms ⁻²]	19.6	9.8

Application of protective tube material:

Material	Resistance in the atmosphere			
	sulfuring oxidative	sulfuring reductive	nitrogening, poor on oxygen	carbonizing
1.4845	good	low	good	satisfactory
1.4841				
1.4749	very good	good	low	low
1.4541	good	low	good	satisfactory
LUNIT 73 *)	very good (suitable for alkaline-free gases and hydrofluoric acid)			
LUXAL 203 *)	very good (contact with alkali vapors allowed to 1500 °C)			

Degree of resistance: 1 – very good 3 – satisfactory (middle)
2 – good 4 - low (unsatisfactory)

*) material suitable for abrasive media, highly chemically resistant and refractory, very fragile, resistance against sudden change of temperature min. 150 K, bending strength for LUXAL 203 is min. 300 MPa, for LUNIT 73 min. 120 MPa

METROLOGICAL DATA

Sensing probe: measuring thermocouple J (Fe-CuNi) or K (NiCr-NiAl) pursuant to EN 60584-1 Ø 6, tolerance class 2 or 1, single with insulated measuring end or double with independent measuring end

Output signal
of the analogue converter (linear with thermoelectric voltage):
4 to 20 mA

of the programmable converter (linear with measured temperature):
4 to 20 mA (+ digital for HART protocol)

Calibration depth of immersion of the measuring insert of the sensor

for temperature points within range -70 to 250°C:
200 mm (min. 160 mm)

for temperature points over 250°C:
300 mm (min. 260 mm)

The distance of flange of the measuring insert from the level of medium in the calibration bath shall be at least 40 mm at temperatures to 250°C and min. 70 mm at temperatures above 250°C.

Temperature response time pursuant to EN 60751 in whirling water

for tube \varnothing 14 mm (characteristic value):	$\tau_{0.5}$	75 s
	$\tau_{0.9}$	90 s
for tube \varnothing 22 mm (characteristic value):	$\tau_{0.5}$	90 s
	$\tau_{0.9}$	370 s

DESIGNATION:

Data on label of head

- Trademark of the manufacturer
- Made in Czech Republic
- Type of the thermoelectric sensor / tolerance class
- Measuring range or set-up converter range
- Product ordering number
- Ingress protection
- Serial number
- Output signal 4 to 20 mA (design with converter)
- Ambient temperature $-40\text{ °C} \leq T_a \leq 70\text{ °C}$
- Designation of non-explosiveness for sensor with metal protective tube:
 - ⊕ II 1/2 G Ex da/db IIC T1...T6 Ga/Gb
 - ⊕ II 1/2 D Ex ta/tb IIIC T=T media Da/Db
 and number of EC Type Examination Certificate
- Designation of non-explosiveness for sensor with ceramic protective tube:
 - ⊕ II 2 G Ex db IIC T1...T6 Gb
 - ⊕ II 2 D Ex ta/tb IIIC T=T media Db
 and number of EC Type Examination Certificate
- Designation of non-explosiveness and No. of EU Type Examination Certificate (for design with converter Ex ia)
- CE mark 1026

Data on label of measuring insert

- Trademark
- Type of sensor / tolerance class
- Serial number

Data on converter label

- Trade mark
- Type of sensor
- Pre-set temperature range
- Designation of non-explosiveness and number of the EU-Type Examination Certificate - for converter Ex ia
- the conformity marking CE (for converter Ex ia with the number of the notified person)

Data on display

- Trade mark
- the conformity marking CE

DELIVERY

Unless agreed otherwise with the customer, each delivery includes

- Delivery note
- Sensor pursuant to the purchase order
- Allen key 1.5 mm
- Separately ordered accessories pursuant to the catalogue of accessories, type 991:
 - o Connecting flange or nipple with threaded ring, an instruction sheet is delivered with each nipple with threaded ring
 - o Suitable cable gland, an instruction sheet is delivered with each cable gland
- Optional accessories to sensor with programmable converter
 - o Configuration (parameterization) programme pursuant to the required converter
 - o Communication modem (for serial port RS 232C) pursuant to the required converter
- Accompanying technical documentation in Czech
 - o Product manual
 - o Product quality and completeness certificate, which also serves as the warranty certificate
 - o EU Declaration of Conformity

If it is established in the purchase contract or agreed otherwise, the following documentation can be also delivered with the product

- Copy of the Inspection Certificate 3.1 for material of protective tube with the heat number
- Calibration sheet (for uncertified calibrated design)
- Test report about the seismic and the vibration qualification
- Copy of EU-Type Examination Certificate pursuant to the Directive No 2014/34/EU (for design with converter and display Ex ia)

CERTIFICATION

- Non-explosiveness Ex ia, EU-Type Examination Certificate pursuant to the Directive 2014/34/EU. FTZÚ 08 ATEX 0200X with supplementary No. 1, 2 and 3
- Non-explosiveness Ex ia, EU-Type Examination Certificate pursuant to the 2014/34/EU (pursuant to the type of the converter and display)

RELIABILITY

Indicators of reliability in operation conditions and ambient conditions specified herein

- Medium time of operation between failures 96 000 hours (inf. value)

Expected service life 10 years

CALIBRATION

It is realized pursuant to TPM 3342-94 and in compliance with EN 60751, usually in three temperature points spread evenly within the operation range of the sensor or in the points according to the requirement of the customer. Calibration sheets with measured data are issued for calibrated sensors.

PACKING

Both sensors and accessories are delivered in a packing ensuring resistance to the impact of thermal effects and mechanical effects pursuant to controlled packing regulations.

TRANSPORT

The sensors may be transported on conditions corresponding to the set of combinations of classes IE 21 pursuant to EN 60721-3-2 (i.e. by airplanes and trucks, in premises that are ventilated and protected against atmospheric effects).

STORAGE

The sensors may be stored on conditions corresponding to the set of combinations of classes IE 12 pursuant to EN 60721-3-1 but with ambient temperature between -20 and 70 °C (i.e. in places where temperature and humidity are not controlled, with a threat of condensation, dripping water and formation of ice, without a special threat of an attack with biological agents, with vibrations of small significance and not situated close to sources of dust and sand.)

TABLE 1 - DESIGN OF TEMPERATURE SENSORS Ex d (Ex t) WITH PROTECTIVE TUBE, TYPE 352

SPECIFICATIONS					ORDERING NUMBER																		
					352	x	x	x	x	x	x	x	x	x	/xxxxxx	/xxx							
Nominal length L [mm]	350	Length of measuring insert L _{mv} [mm]	375	Length h L1 [mm]	200	1																	
	500		525			2																	
	710		735			3																	
	800		825			4																	
	1000		1025		400	5																	
	1400		1425			6																	
	1600		1625			7																	
	2000		2025			8																	
	Other (max. 3000, ceramic tube max. 1600 *)						9																
Extension length	Without extension					0																	
Material of protective and maximum measuring range of the sensor	1.4845 or 1.4841 max. -70 to 450°C ***)																						
	1.4541 max. -70 to 450°C ****)																						
	1.4749 (only for Ø 22 mm) max. -70 to 450°C ***)																						
	LUNIT 73 *) max. 0 to 450°C *****)																						
	LUXAL 203 *) max. 0 to 450°C *****)																						
Other *) **)																							
External ø of protective tube [mm]	14																						
	22																						
	22 cantilevered metal tube, 15 ceramic tube																						
Head of the sensor with thread for gland Ex d (Ex t) - overview of glands see Tab.4,5	Aluminium alloy painted with blue epoxy colour		M20x1.5																				
			1/2-14NPT																				
	Corrosion-resistant steel 1.4401		M20x1.5																				
			1/2-14NPT																				
Measuring insert tube for sensor with protective tube (Ø6 ± 0,1 mm)																							
Thermocouple	K																						
	J																						
	Other *)																						
Tolerance class	1 *)																						
	2																						
Design of measuring ends of thermocouple pursuant to Figure 4	Single thermocouple, insulated end																			/JI			
	Double thermocouple, independent end																				/DU		
Converter (design of thermocouple measuring ends: single thermocouple, isolated end)	Converter type		Galvanic separation	Ex ia	Range [°C]																		
	Analogue linear output signal with thermoelectric voltage	APAQ-HRF			Adjustable range																/HRF		
		APAQ-HRFX		•																		/HRFX	
	Programmable linear output signal with temperature	TH 200	•																			/TH200	
		TH 200-ex	•	•																			/TH200X
		IPAQ-H	•																				/IPAQH
		IPAQ-HX	•	•																			/IPAQHX
		MINIPAQ-HLP																					/MINIPAQ
		IPAQ C330	•																				/C300
	Programmable with HART protocol linear output signal with temperature	IPAQ C330X	•	•																		/C300X	
		TH 300	•																			/TH300	
		TH 300-ex	•	•																		/TH300X	
		MESO-H	•																			/MESOH	
		MESO-HX	•	•																		/MESOHX	
		248 HA NA	•																			/248HANA	
248 HA I1	•	•																		/248HA1X			
644 HA NA	•																				/644HANA		
644 HA I1	•	•																			/644HA1X		
Other *)																					/99		
Without converter (for installation of the converter by the customer)																					/00		
LED display to loop 4-20 mA (not possible with head from corrosion resistant steel) (only with converter APAQ-HRF, MINIPAQ-HLP)					LPI-02																/LD		

Standard design

- *) Only as a special requirement after an agreement with the manufacturer
- **) For Zone 0, a thermowell from corrosion-resistant alloy shall be used (pursuant to EN 60079-26)
- ***) Sensor measuring range up to 1100°C in case of a type of installation pursuant to Figure 1 and when used in hot air, in other atmospheres the maximum temperature can be up to 200 ° C lower
- ****) Sensor measuring range up to 800°C in case of a type of installation pursuant to Figure 1 and when used in hot air, in other atmospheres the maximum temperature can be up to 200 ° C lower
- *****) up to 1300 ° C (short-term 1500 ° C) in case of a type of installation pursuant to Figure 1
- *****) up to 1600 ° C (short-term 1800 ° C) in case of a type of installation pursuant to Figure 1

**WARNING**

The upper limit of the measurement range is limited by resistance of the thermocouple (max. 1150°C for thermocouple K, max. 800°C for thermocouple J, for another type of thermocouple, the upper limit of the measurement range of the thermocouple is given of resistance this thermocouple), said upper range limit is considered in hot air.

TABLE 2 – ADDITIONAL REQUIREMENT FOR DESIGN OF TEMPERATURE SENSORS Ex d (Ex t) TO THERMOWELL, TYPE 333

SPECIFICATIONS			CODE	
CALIBRATION	NUMBER OF CALIBRATION POINTS	CALIBRATION RANGE		
Calibration by TPM 3342-94, define calibration points	3	0 to 800 °C	/Q4	
	3	0 to 1100 °C	/Q42	
	Other	0 to 1100 °C	/Q9	
REQUIREMENT FOR OTHER DOCUMENTATION		USE		
EU Declaration of Conformity		for design with converter		/EU
Copy of EU-Type Examination Certificate acc to the 2014/34/EU (ATEX)		for converter and display Ex ia		/Exi
Declaration of Conformity with purchase order 2.1 pursuant to EN 10204				/2.1

Specify the code behind ordering number. Define calibration points for codes Q4, Q42 a Q9.

ORDERING TEMPERATURE SENSORS

The purchase order shall specify

- Name
- Product ordering number
- Additional requirements for sensor design according to Table 2
- Request for additional documentation according to the Table 2
- Measuring range
- If calibration is required and in what temperature points
- If a connecting flange or a nipple with threaded ring is required
- If the delivery of the gland for the output cable is required as accessories to the sensor pursuant to the type 991
- If optional accessories to the sensor with programmable converter are required
- Request for other documentation according to Article DELIVERY
- Other (special) requirements
- Number of pieces

Behind the ordering number specified pursuant to the above mentioned table, the customer shall identify the required range of measured temperature (i.e. lower and upper temperature limits in °C) and, as the case may be, other non-standard required parameters for converter configuration (e.g. indication of sensor tripping, dampening, required designation - tagging etc.).

PURCHASE ORDER EXAMPLE**Standard design:**

Thermoelectric temperature sensor Ex d (Ex t) with metal protective tube without converter
352 201 01K2/JI/Q4
Calibration points 250, 350 and 450°C
range -70 to 450°C
6 pcs

Special request:

Thermoelectric temperature sensor Ex d (Ex t) with metal protective tube with converter
352 901 112 J2/HCF
nominal length L = 380 mm, range 0 to 300°C
6 pcs

ORDERING ACCESSORIES

The purchase order shall specify:

- Name
- Product ordering number
- Number of pieces

PURCHASE ORDER EXAMPLE

1. Connecting flange
991 UP 14
5 pcs
2. Cable gland
991 VM 612
5 pcs

TABLE 3 - ACCESSORIES - OVERVIEW OF DESIGNS RECOMMENDED FLANGES AND NIPPLES (to be ordered separately)

SPECIFICATIONS			ORDERING NUMBER
Connecting flange	for protective tube Ø 14 mm		991 UP 14
	for protective tube Ø 22 mm or cantilevered metal tube of ceramic tube Ø 15 mm		991 UP 22
Nipple with threaded ring for protective tube Ø 14 mm	Material	carbon steel 1.0122	991 NVP6 D14 13
		stainless steel 1.4541	991 NVP6 D14 72
Nipple with threaded ring for protective tube Ø 22 mm or cantilevered metal tube of ceramic tube Ø 15 mm	Material	carbon steel 1.0122	991 NVP6 D22 13
		stainless steel 1.4541	991 NVP6 D22 72

TABLE 4 - OVERVIEW OF DESIGNS AND ORDERING OF CABLE GLANDS Ex d (Ex t) BRASS – TYPE 991

SPECIFICATION							Ordering number			
Gland Ex d (Ex t) brass		Cable clamp (clamping module)			Thread	Torque of gland body	For cable Ø [mm]	991	xx	xxx
Size	Wrench A B	Size	Dimension C Ds							
No. 4	OK 17	OK 24	No. 4	5	20	M20×1.5	30 - 35 Nm	4,5-8.5	VM	458
No. 5	OK 19		No. 5	5	22			7-11	VM	711
No. 6	OK 24		No. 6	6	27.5			10-16	VM	016
No. 4	OK 17		No. 4	5	20	1/2-14 NPT	25 - 30 Nm	4,5-8.5	VK	458
No. 5	OK 19		No. 5	5	22			7-11	VK	711
No. 6	OK 24		No. 6	6	27.5			10-15.5	VK	015

TABLE 5 - OVERVIEW OF DESIGNS AND ORDERING OF CABLE GLANDS Ex d (Ex t) BRASS – TYPE 991

These glands will be delivered until stocks sell out

SPECIFICATION							Ordering number			
Gland Ex d (Ex t) brass		Cable clamp (clamping module)			Thread	Torque of gland body	For cable Ø [mm]	991	xx	xxx
Size	Wrench		Size	Dimension						
	A	B		C	Ds					
No. 5	OK 19	OK 24	No. 5	5	22	1/2-14 NPT	25 - 30 Nm	6-12	VM	612

INSTALLATION AND CONNECTION

SENSOR INSTALLATION

The sensors are installed by means of a connecting flange or by means of a weld-on with threaded ring.

SENSOR WITH METAL PROTECTIVE TUBE INSTALLATION



WARNING



The metal protective tube of temperature sensor may be install to the thermowell located in the zone 0 (20), zone 1 (1) or zone 2 (22).

The other parts of the sensor (fitting, adapter, connecting head) may be located in zone 1 (21) or zone 2 (22).

When installing sensor in the thermowell located in zone 20, a pre-fuse with the following parameters must be used in the converter encoder circuit: Ceramic, quick break (F), short circuit resistance 1500A (H), e.g. ceramic tube fuse Ø5 x 20 mm, F100mA.

Distance of the fixed closure Ex d IIC from close structures or between the closures shall be at least 40 mm.

The temperature sensor with a paint finish must be installed in an explosive atmosphere with dust so as to avoid the occurrence of creep discharges

SENSOR WITH CERAMIC PROTECTIVE TUBE INSTALLATION



WARNING

Fix sensor to the cantilevered metal tube!

Install the sensor so that the cement joint is out of reach of high temperatures due to the different thermal expansion of the cantilevered metal tube and the ceramic protective tube.

When installing or changing the sensors during operation, slide them in and out of the high-temperature environment gradually (about 20 mm in 1 minute) to avoid rupture ceramic protective tubes due to thermal stress caused by a rapid temperature change.

If slow sensor movement is not possible, ensure at least its slow and even preheating.



WARNING



The ceramic protective tube of temperature sensor may be install to the thermowell located in the zone 0 (20), zone 1 (1) or zone 2 (22).

The other parts of the sensor (fitting, adapter, connecting head) may be located in zone 1 (21) or zone 2 (22).

Distance of the fixed closure Ex d IIC from close structures or between the closures shall be at least 40 mm.

INSTALLATION OF THE NIPPLE WITH THREADED RING shall be realized pursuant to the instruction label as follows:

- 1) Uninstall the complete nipple by unscrewing the cap nut
- 2) Weld the nipple itself (after possible shortening) onto the wall of the piping or another technological equipment
- 3) On the metal protective tube of the rod temperature sensor, put the cap nut, thrust ring and threaded ring in the said order,
- 4) Slide the temperature sensor with put-on components pursuant to point 3 into the prepared nipple and only tighten it adequately after the definitive selection of immersion (recommended torque is 60 to 70 Nm).



WARNING

Length of the immersion part of the sensor cannot be changed repeatedly; the sensor can only be uninstalled!

With respect to maintaining metrological properties and the longest possible service life, it is not recommended to install the sensors in places with high turbulence of the medium, which is caused e.g. by a rapid transition from a small diameter of the piping to a larger one (when failing to comply

with the required shape and dimensions of diffuser behind the flow meter), etc. Recommended distance of the temperature sensor from the installation flange of the flow meter is min. 1 m.

NIPPLE WITH THREADED RING

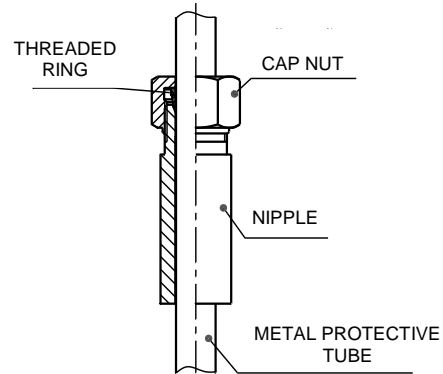

INSTALLATION OF FLANGES

Weld bottom part of the flange onto the wall of the technological equipment. After releasing two screws M6x14, you can move the sensor in the connecting flange, whereby the required immersion of the sensor can be adjusted.

CONNECTING FLANGE 991 UP 14 A 991 UP 22

(quotation for 991 UP 22 in parentheses)

INSTALLATION EXAMPLE

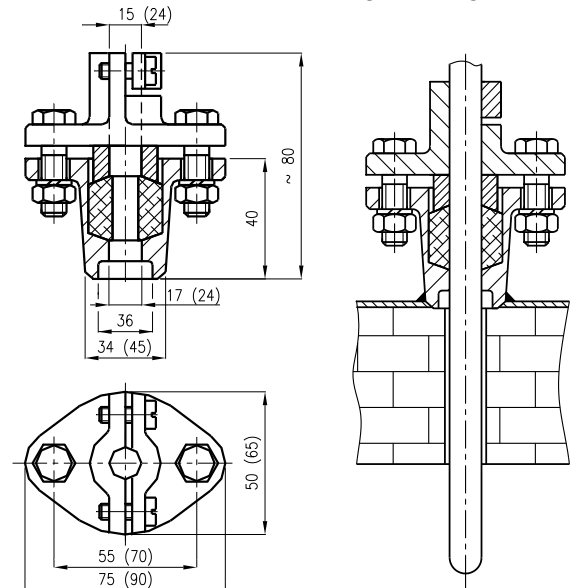

INSTALLATION OF CABLE GLAND

To secure the fixed and dust-tight closure, only the certified cable gland Ex d IIC (Ex tb IIIC) with Ingress protection IP 68 shall be used (refer to accessories 991 or another similar gland). For temperature sensors with converter, a barrier cable gland must be used in zone 1 of the IIC gas group or an Ex ia converter must be used. It shall be tightened in the sensor head in the prescribed way.

Torque of gland body:

- a) for gland with thread 1/2 - 14NPT 25 – 30Nm
- b) for gland with thread M20x1.5 30 – 35Nm

Installation of the cable in the gland, its sealing and securing against pull-out shall be realized pursuant to the instruction sheet of the gland supplier.

**WARNING**

Do not use other sealing rings in the gland than the original ones delivered by the manufacturer. Do not change artificially the outer diameter of the cable e.g. by winding it around with electrical insulating tapes.

ELECTRICAL CONNECTION

The electrical connection may be only realized by qualified workers.

The sensor installation in conditions with explosive gaseous atmosphere or flammable dust shall comply with the requirements of EN 60079-14.

The terminal board of the sensor (converter) is accessible after unscrewing the lid of the head.

Connect the evaluation devices to the sensor with a cable with double insulation; internal wires with Cu core (sensor with converter) or compensation wiring (sensor without converter) 0.5 to 1.5 mm². Sensors without converter connect with unarmoured shielded compensation or double insulated thermocouple wiring with cross section 0.5 to 1.5 mm² and outer diameter according to cable gland.

Seal the cable in the gland by prescribed tightening of the closing nut pursuant to the instruction sheet of the gland. Then secure it with a clamp against pull-out.

**WARNING**

The connecting cable must have a casing of thermoplastic, thermoset or elastomeric materials. The cable must be circular and compact, the filler or shell must be extruded and the filler material, if used, must be non-absorbent. The length of the connecting cable must be at least min. 3 m. Temperature resistance of the cable shall comply with the ambient temperature!

The cable insulation shall have chemical and mechanical resistance in compliance with the conditions, in which the cable will be installed. It is recommended supporting the cable along its length between the sensor and the follow-up device. In the environment with interfering signals, use shielded cable in the power supply circuit. Shielding may be only grounded (earthed) in one point. The cable should not be placed together with power cables.

In case of the sensor with HART protocol converter, the maximum length of wiring is defined by the arrangement of wires of the connecting cable. The total length of wiring may be up to 1500 m. It requires a twisted two-wire with shared shielding with the cross section of the core min. 0.5 mm². Recommended HART communicator, model 275, is connected to the supply loop of the converter pursuant to Figure 3. To achieve reliable communication, resistor 250 Ω shall be introduced in the circuit of the output loop.

**WARNING**

Programmable converter may not be connected to a computer or a HART communicator if the converter is located in explosive environment.

The surface temperature of the converter must not exceed the maximum surface temperature for a given temperature class.

For the installations in dangerous areas, mutual connection is required (bringing to the same potential). To achieve it, terminals on the sensor head can be achieved.

The sensor need not be connected to the system of mutual connection independently if it is installed firmly and has metal interconnection with the structural parts or the piping, which is connected to the system of mutual connection.

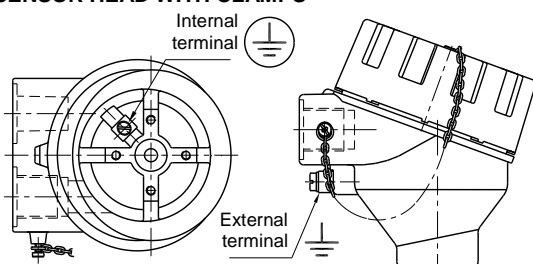
SENSOR HEAD WITH CLAMPS**Maximum cross-section of wire for connection to external and internal terminals:**

Internal terminal: stranded wire 1.5 mm², full wire 2.5 mm²

External terminal: stranded wire 4.0 mm², full wire 6.0 mm²

If stranded wires are used for the interconnection, they shall be protected against fraying with pressing hollow.

CLOSING HEAD OF FIXED CLOSURE Ex d

After electrical connection of the sensor, the lid of the head shall be fully tightened by hand, then released slightly to ensure matching with the closest groove against the securing screw and fixed by this screw against releasing. If the lid of the sensor is not tightened and secured with the above mentioned screw, the sensor does not comply with the requirements of fixed closure Ex d.

**WARNING:**

Power supply of the sensor may not be connected before closing the fixed closure!

**SENSOR INSTALLATION WITHOUT CONVERTER AND SENSOR WITH CONVERTER Ex ia TO ZONE 0 (20)****WARNING:**

The user is responsible for ensuring that during operation in zone 0 is between the sensor head from an aluminium alloy and other equipment preclude any risk of ignition due to impact and friction.



The sensor without converter can be used, in case of the installation pursuant to EN 60079-11, Art. 5.7 in the intrinsically safe circuit Ex ia according to EN 60079-25), as a simple equipment. For simple equipment, the maximum temperature can be determined from the value of the P₀ of the follower and the temperature class is determined.

Sensor with converter Ex ia can be used while adhering to the Ex ia parameters of the converter shall be complied with pursuant to the enclosed converter manual.

In intrinsically safe circuits, only insulated cables that are capable of withstanding an electrical strength test with a voltage equal to twice the voltage in the intrinsically safe circuit or 500 V eff (DC 750 V) must be used, with a larger value being taken.

When installing intrinsically safe circuits, including cables, do not exceed the maximum allowable inductance, capacity or ratio LiR and surface temperature. Permissible values are determined from the documentation of the connecting device or label. Place follow-up equipment out of the danger area. An intrinsically safe source approved for supplying intrinsically safe devices in accordance with EN 60079-11 must always be used.

The shield of the intrinsically safe circuit cable must be grounded in the same place as the intrinsically safe circuit, the connection must be outside the dangerous area.

If the intrinsically safe circuit is isolated from the ground, the shield must be connected in one place to the protective interconnection system. This can be using the terminals on the sensor head.

COMMISSIONING

After the sensor installation, including closing the fixed closure, and connection of the follow-up (evaluation) device to the supply voltage (and the settlement period of the converter), the equipment is prepared for operation.

**WARNING**

After installation must be require initial inspection equipment and installations according to EN 60079-17

**OPERATION AND MAINTENANCE**

The sensor does not require any operation, maintenance and follow-up periodical revisions or permanent supervision of expert staff shall be carried out pursuant to EN 60079-17.

**WARNING**

Any intervention into the sensor and its structure will result in a change of properties and can result in an explosion!



SENSOR UNINSTALLATION



WARNING



Warning: Temperature sensor is in design Ex and must be disconnected from the power supply source before opening the lid of the head and releasing the cable gland in the explosive environment!

Release the securing screw of the lid with ALLEN key 1.5 mm (a part of accessories). The terminal board of the sensor (converter) is accessible after unscrewing the lid of the head. Measuring insert of the sensor can be replaced and is uninstalled from the head after disconnecting the cable by releasing two screws.

Before a complete uninstallation of the sensor, the wire for mutual interconnection shall be released from the external terminal on the sensor.

Disconnect the connecting cable from the terminal board, then release it from the clamp on the gland and from the closing nut of the gland. After releasing the screws on the connecting flange (unscrewing the nut on the nipple with threaded rings), remove the sensor.

SPARE PARTS

Spare parts shall be delivered by the manufacturer. Relevant measuring inserts can be ordered pursuant to the following table:

SPECIFICATIONS		ORDERING NUMBER					
		MV350	/xxx/	x	x	x	/xxx
Length of measuring insert [mm]		Pursuant to tab. 1	1				
Sensing probe	Thermocouple K				K		
	Thermocouple J				J		
	Other *)				9		
Accuracy class	1					1	
	2					2	
Connection of the terminal board and design of measuring ends of thermocouple or converter	Single thermocouple, insulated end						/JI
	Double thermocouple, independent end						/DU
Converter pursuant to tab. 1							/converter

*) Only as a special requirement after an agreement with the manufacturer

EXAMPLE OF PURCHASE ORDER OF MEASURING INSERT

Thermoelectric measuring insert without converter
 MV350 /735/ 1K2/JI
 6 pcs

To order the certified measuring inserts, specify the code according to Table 2 – Additional requirements – behind the ordering number.

The measuring inserts are marked according to Article DESIGNATION. Designation is completed with the ordering number.

Each delivery includes

- Delivery note
- Measuring insert pursuant to the purchase order
- Optional accessories to the measuring insert with a programmable converter
 - o Configuration program according to the required converter
 - o Communication modem (for serial port RS 232C) according to the required converter
- Accompanying technical documentation in Czech
 - o Product manual
 - o Product quality and completeness certificate, which also serves as the warranty certificate
 - o EU Declaration of Conformity (for design with converter Ex ia)

If it is established in the purchase contract or agreed otherwise, the following documentation can be also delivered with the product

- Calibration sheet (for calibrated design)
- EU Declaration of Conformity (for design with converter)
- Copy of EU-Type Examination Certificate pursuant to the Directive No 2014/34/EU for design with converter Ex ia

WARRANTY

The warranty period is 24 months from the receiving of the product by the customer, unless established otherwise in the contract. Rejection of defects shall be enforced in writing at the manufacturer within the warranty period. The rejecting side shall identify the product name, ordering and manufacturing numbers, date of issue and number of the delivery note, clear description of the occurring defect and the subject of the claim. If the rejecting side is invited to send the device for repair, it shall do so in the original package of the manufacturer and/or in another package ensuring safe transport.

The warranty shall not apply to defects caused by unauthorized intervention into the device, its forced mechanical damage or failure to comply with operation conditions of the product and the product manual.

REPAIRS

The sensors shall be repaired by the manufacturer. They shall be sent for repair in the original or equal package without accessories.

DISABLING AND LIQUIDATION

The product and its package do not include any parts that could impact the environment.

The products that are withdrawn from operation, including their packages (with the exception of products marked as electrical equipment for the purposes of return withdrawal and separate salvage of electrical waste), may be disposed of to sorted or unsorted waste pursuant to the type of waste.

The manufacturer realizes free return withdrawal of marked electrical equipment (from 13.8.2005) from the consumer and points out the danger connected with their illegal disposal. The package of the sensor can be recycled completely. Metal parts of the products are recycled, non-recyclable plastic materials and electrical waste shall be disposed of in accordance with applicable legislation.

FIGURE 1 - EXAMPLES OF INSTALLATION OF TEMPERATURE SENSORS Ex d WITH METAL PROTECTIVE TUBE
 (in case a higher upper limit of the range of measurement is required than the required temperature class)

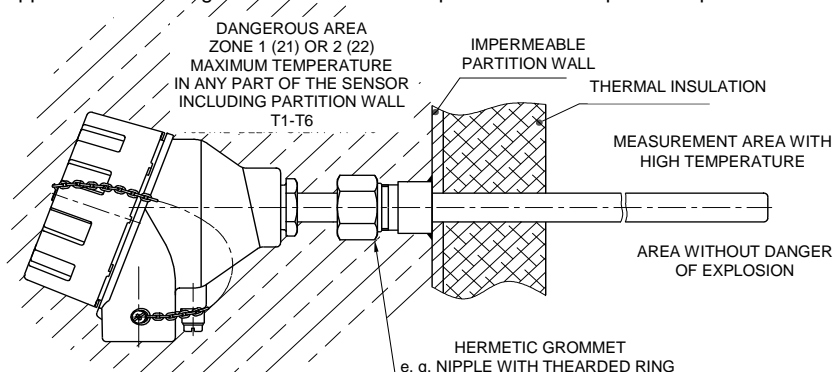
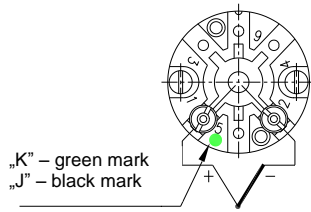

FIGURE 2 - SCHEME OF CONNECTION OF TEMPERATURE SENSORS

SCHEME OF CONNECTION WITHOUT CONVERTER

with single thermocouple



with double thermocouple

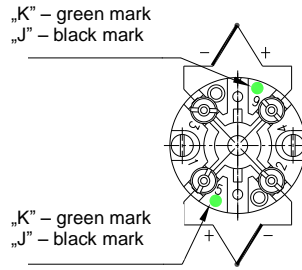

SCHEME OF CONNECTION WITH CONVERTER AND DISPLAY

with converter

with converter with HART protocol

with converter Ex ia

with converter Ex ia with HART protocol

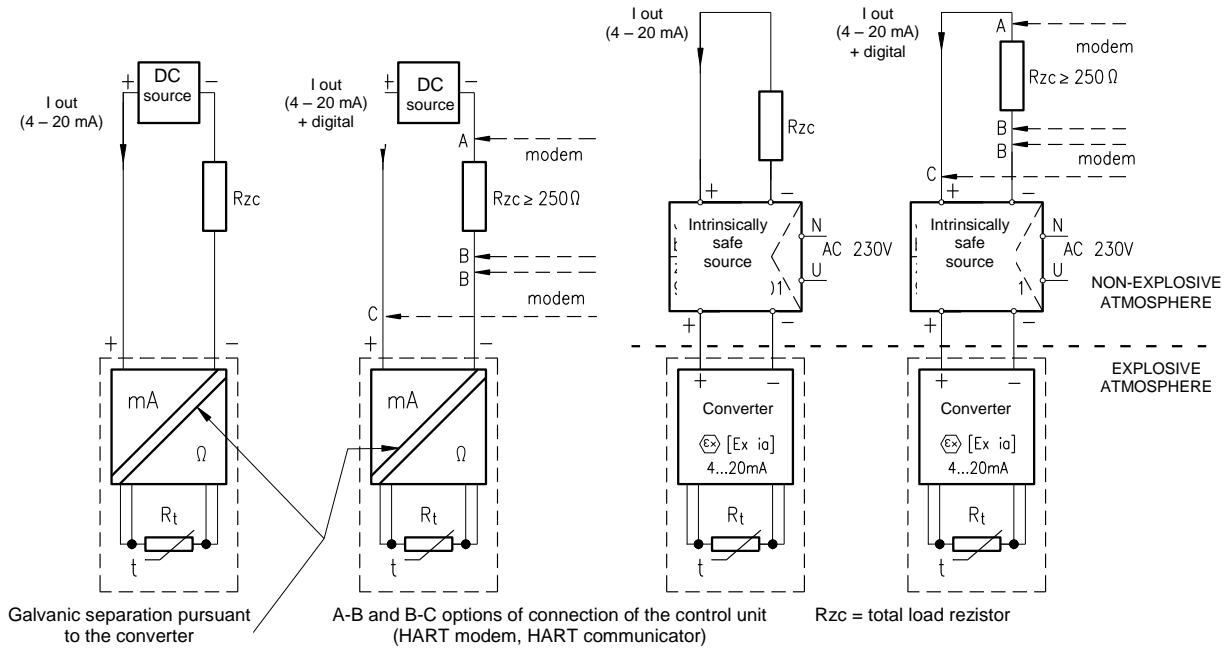

FIGURE 3 - EXAMPLE OF OPERATION CONNECTION OF TEMPERATURE SENSOR WITH CONVERTER IN LOOP 4 - 20 mA

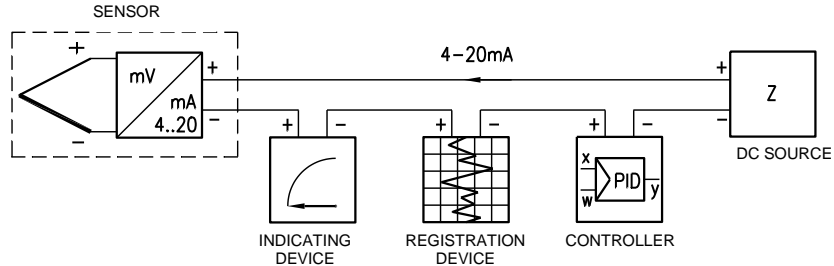
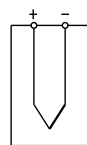

FIGURE 4 - DESIGN OF MEASURING ENDS OF JACKETED THERMOCOUPLES (SCHEMATIC ILLUSTRATION)

INSULATED END
design I
(standard pro simple design)



J1

INDEPENDENT END
design U
(standard pro double design)

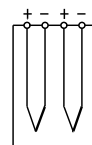

DU

FIGURE 5 – MARK OF NON-EXPLOSIVENESS

for sensor with metal protective tube

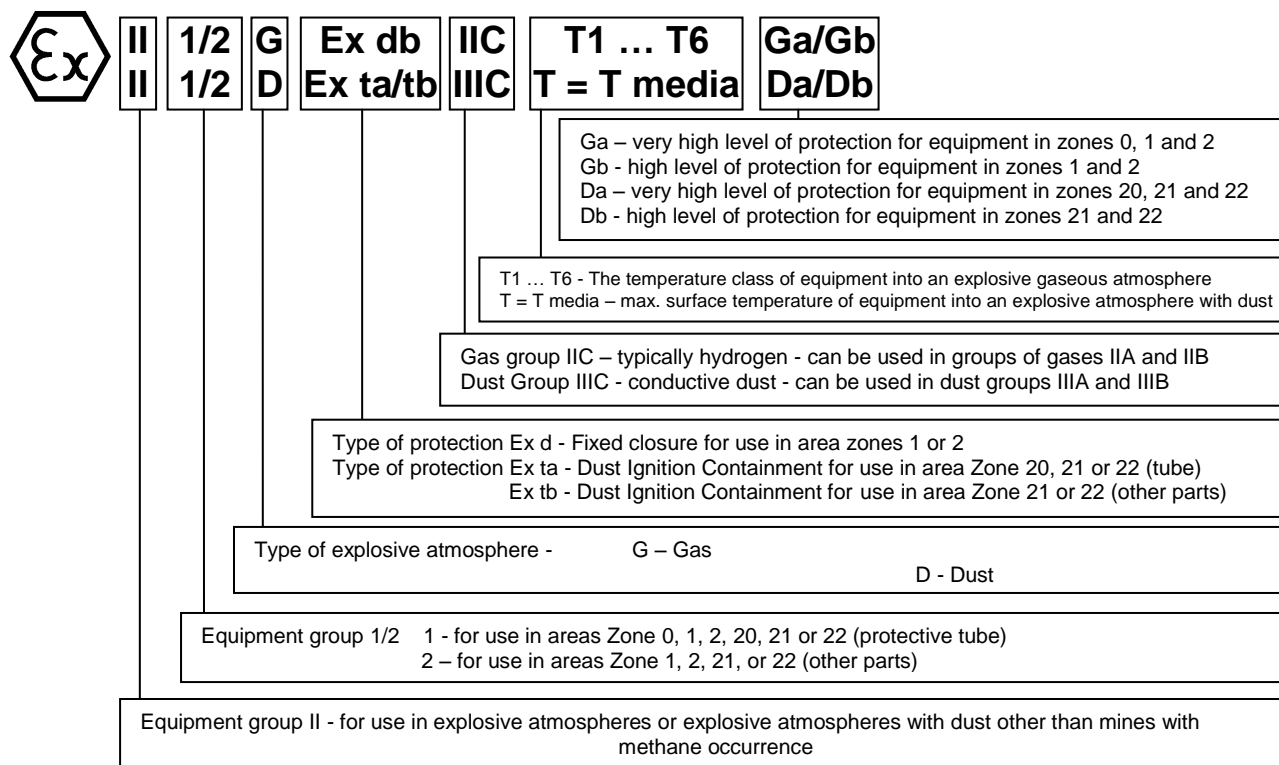

for sensor with ceramic protective tube

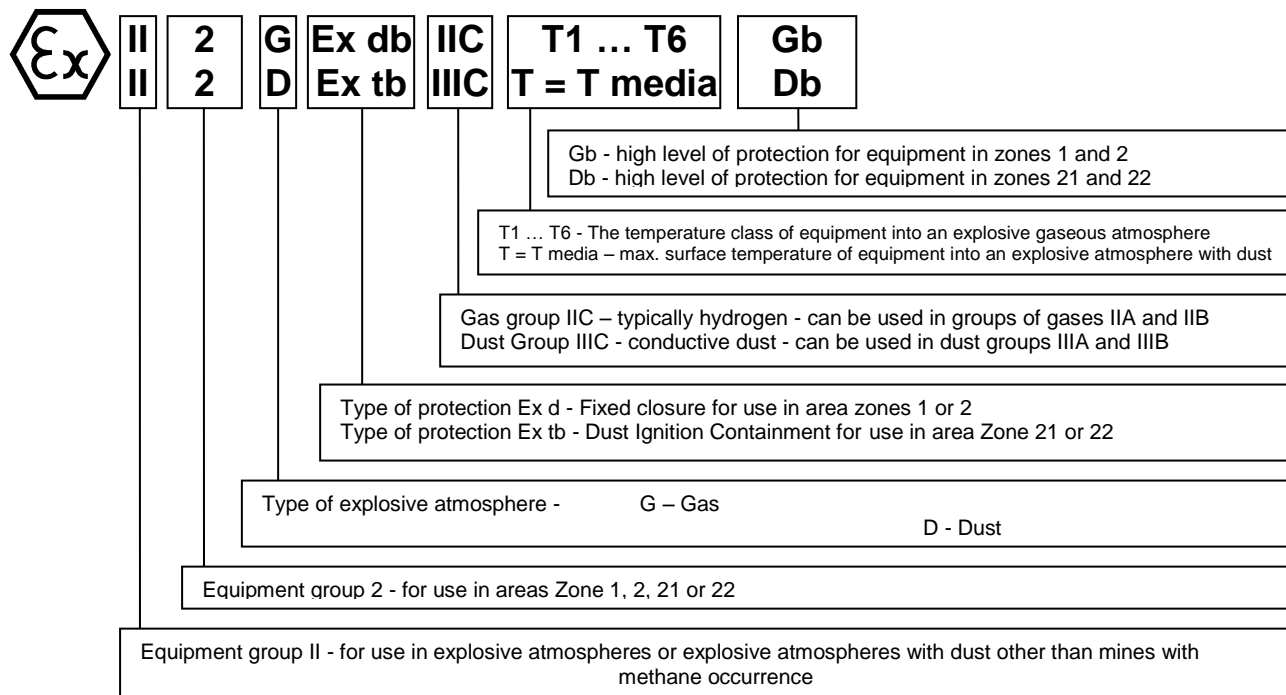

October 2018

© ZPA Nová Paka, a.s.

