



PRODUCT MANUAL

Servomotor controller NOTREP 21 type 511 21
 Servomotor controller NOTREP 22 type 511 22
 Servomotor controller NOTREP 25 type 511 25
 Servomotor controller NOTREP 26 type 511 26
 Design NK1

APPLICATION

The controllers are used for continuous control of the servomotors MODACT with motors of type J9A (16 W), J10A (25 W), J11A (50 W) of ATAS elektromotory Náchod a.s.

The controllers are rated products pursuant to the Directive 2014/30/EU, 2014/35/EU of the European Parliament Coll. and the Declaration of Conformity **EU-511210** is issued for them.

DESCRIPTION

In terms of design, the controllers are solved on printed circuit boards in plug-in units of the design kit pursuant to Figure 1. The unit has two connecting connectors, one for power circuits and another one for signal circuits. On the face cover, there are fuses and holes for access to the potentiometers for adjustment.

The controllers of type 511 21 and 511 25 are plug-in units delivered independently.

In case of the controllers 511 22 and 511 26, the plug-in unit is installed in a box from steel metal sheet covered with a lid. The wires are brought in through stuffing box bushings.

PRINCIPLE

The controller is a high-power amplifier, which controls the size of voltage brought to the servomotor. It operates as a contactless switch at the output with bidirectional triode thyristors, the angle of opening of which controls the generator of switching impulses synchronized with alternating signal derived from the mains supply voltage.

The two-phase servomotor MODACT is designed so that the winding of the excitation phase has the same electrical parameters of the winding of the control phase. It enables, in case of single-phase power supply from the controllers, to perform reversing of revolutions by the exchange of both windings. That is why the controller has two output bidirectional triode thyristors switches, of which each controls one sense of rotation of the motor pursuant to the polarity of the control signal. The phase shift of 90° of voltage of the excitation and control phase is achieved by serial connection of the condenser with one winding.

In case of controllers with current feedback pursuant to figure 6, in the input circuit, the control signal and the current signal are modified from the position feedback pursuant to the selected range and the signals are deducted. The range of the input and feedback signals are selected by the interconnection of the tips pursuant to Article COMMISSIONING, SELECTION OF RANGES OF THE CONTROLLERS. The created signal of difference of the control signal and the actual position is amplified in the amplifier and brought to the input of the generator of ignition impulses. The generated ignition impulses control the bidirectional triode thyristors via the separation transformers. For each polarity of difference of the input and feedback signal, there is one operating bidirectional triode thyristor. The synchronization is realized with the alternating signal from the secondary winding of the power supply transformer.

The controller is equipped with the circuit for monitoring the interruption of the feedback and input signal, which can be used for the range 4 to 20 mA. A signal failure is reported by switching the contact of the relay RL 2 and, at the same time, the controller is automatically switched over with the use of the relay RL 1 to the manual control mode. The circuit for monitoring and signalling of tripping of the signals can be put out of operation by disconnecting the tips pursuant to Article COMMISSIONING, SELECTION OF RANGES OF THE CONTROLLERS.

FIGURE 1 - DIMENSIONAL DRAWING OF PLUG-IN UNITS OF THE CONTROLLERS OF TYPE 511 21 AND 511 25

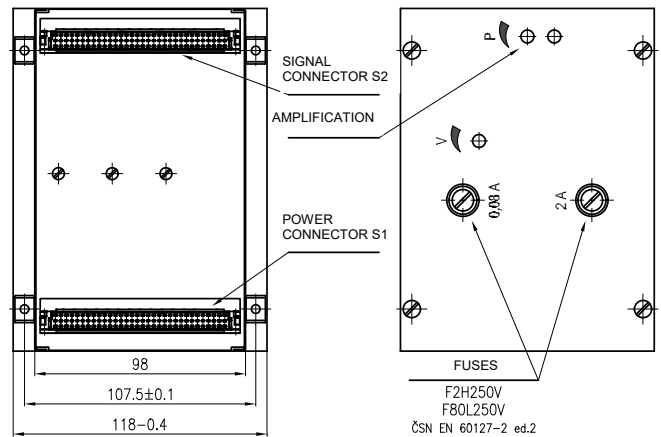
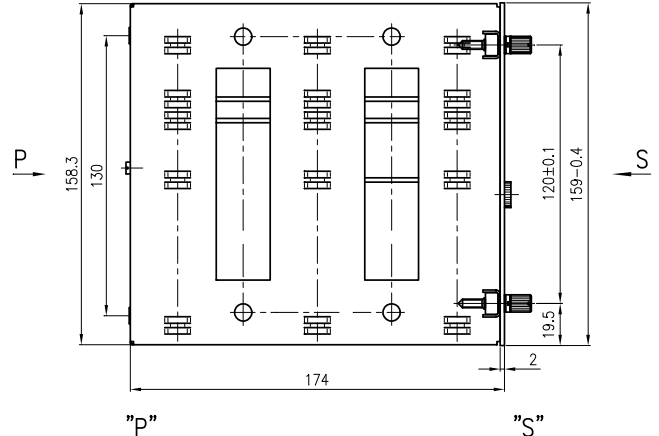
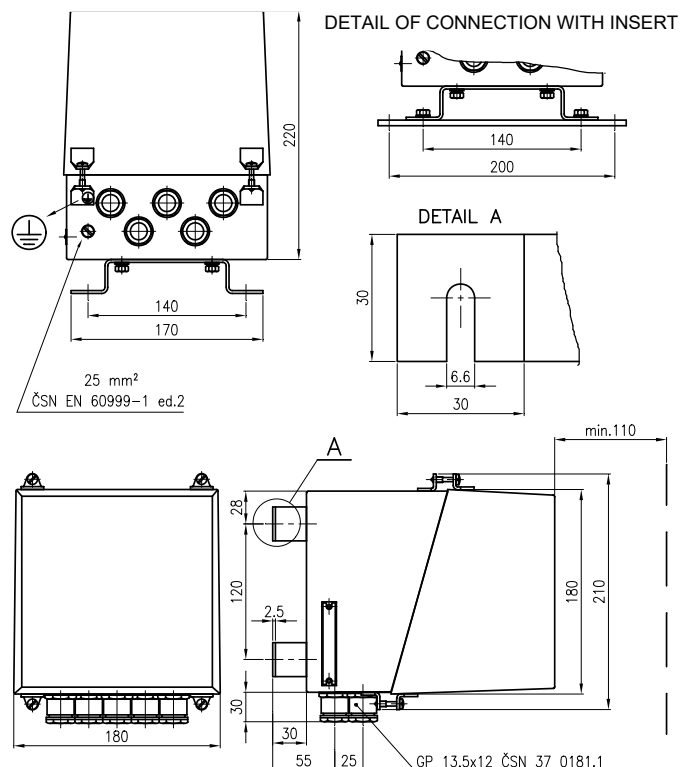

FIGURE 2 - DIMENSIONAL DRAWING OF THE CONTROLLERS IN A BOX TYPE 511 22 AND 511 26



The relay RL 1 is used for transition to the manual control of the servomotor with push-buttons. During the transition to the manual control, the relay drops out, which disconnects voltage from winding of the brake, the motor is stopped and the winding of both phases of the motor is switched over to the circuits of the controllers to the output terminals, where the push-buttons are re-connected – refer to Figure 4 - Installation, operation and maintenance manual. By pressing one of the push-buttons, full voltage is applied to the motor and the winding of the brake. The manual control is put out of operation pursuant to Article COMMISSIONING, SELECTION OF RANGES OF THE CONTROLLERS. Power circuits of the controller are secured against short-term voltage peaks with a varistor overvoltage protection.

TECHNICAL DATA

Design of device:

The device is designed pursuant to EN 61140 as an electrical equipment of protection class I for the application in networks with category of overvoltage in installation II and pollution grade 2 pursuant to EN 61010-1, the inner source for power supply of the feedback circuit complies with Article 6.3 of the said standard and it also complies to the circuits SELV and PELV.

The controller in a box has an internal protective clamp and an external protective clamp, which are mutually interconnected.

The plug-in unit is only designed for building-in.

The controller has a fuse of the mains power supply.



Warning!

Before the removal or plugging-in of the mains unit, the mains power supply shall be switched off.

Electric strength pursuant to EN 61010-1, Article 6.8.4:

- a) Power circuits: AC 2200 V
- b) Signal circuits: AC 3700 V
- c) Input circuit for the control signal against/feedback input: AC 500 V (type 511 25, 511 26)

Electric insulation resistance: min. 20 MΩ

Power supply

Type of supply mains: 1/N/PE AC 230 V, 50 Hz

Tolerance of supply voltage: ±10 %

Tolerance of mains frequency: 48 to 62 Hz

Coefficient of upper harmonics: max. 10 %

Electric power input: without motor max. 20 VA
 for motor 50 W approx. 330 VA
 for motor 25 W approx. 230 VA
 for motor 16 W approx. 150 VA.

Ingress protection pursuant to EN 60529:

Plug-in units: IP 00

In a box: IP 54.

Independent plug-in units shall be located in Ingress protection IP 54

Operation position:

Discretionary; in case of controllers in a box, the outlets shall face down

Warm-up period after switching power supply on: 10 minutes

Weight: plug-in unit: approx. 1.6 kg
 in a box: approx. 5 kg

Type of operation: continuous

Used materials:

Box: steel metal sheet, painted with grey varnish
 Frame of plug-in unit: steel metal sheet, galvanized

Electric connection:

Terminals: screw type, for cross-section of wires up to 1.5 mm²

Transition pieces: GP 13.5x12 pursuant to ČSN 37 0181.1 for cross-section of cable 9 to 12 mm

OPERATION CONDITIONS

The environment is defined by a group of parameters and their severity grades IE 33/IE 36 pursuant to EN 60721-3-3, but the level of vibrations only to amplitude 0.15 mm and the following operation conditions.

Ambient temperature: -20 to 55 °C

Relative ambient humidity:

5 to 85 % with condensation, with upper level of water content 29 g H₂O/ m³ of dry air

Atmospheric pressure: 70 to 106 kPa

Vibrations pursuant to EN 60068-2-6:

- Frequency range [Hz] 10 to 150
- Drift amplitude [mm] 0.15
- Acceleration amplitude [m.s⁻²] 19.6

Electromagnetic compatibility:

The radiation complies with the standard EN 61000-6-4, resistance meets EN 61000-6-2.

METROLOGICAL DATA

Input control signal - input resistance:

0 to 10 V - 60 kΩ

0 to 20 mA - approx. 40 Ω

4 to 20 mA - approx. 50 Ω

For the type 511 25 and 511 26, the input circuit for the control signal has galvanic separation from the input circuit for the feedback signal.

These types have a fixed range for the input signals:

4 to 20 mA - input resistance approx. 50 Ω

Amplification of input signal:

continually adjustable in ratio 1 : 4

Proportional band of input signal:

max. 1 % at biggest amplification

Dead band of input signal:

max. ± 0.2 % at biggest amplification within the whole range of operation conditions

Feedback signal

- input resistance:

0 to 10 mA - approx. 40 Ω for types 511 21, 511 22

4 to 20 mA - approx. 50 Ω for types 511 21, 511 22

4 to 20 mA - approx. 50 Ω for types 511 25, 511 26

Output voltage for servomotor:

0 to min. 209 V at supply voltage AC 230 V

In case of a change of the supply voltage, the change of the output voltage is proportional.

Carrying capacity of signalling contact:

of all types: 30 VA, max. 48 V

RELIABILITY

Reliability indicators in operation conditions and ambient conditions identified in this manual

- Mean period of operation between failures 96 000 hours (inf. value)
- Expected service life 10 years

DESIGNATION

Data on the production label on the device cover:

- Trademark of the manufacturer
- Made in Czech Republic
- Product number
- Production number
- Type of supply mains
- Ingress protection
- CE mark

DELIVERY

The controllers are delivered with interconnected tips for the selection of ranges, feedback and monitoring of interruption of signals pursuant to TABLE 1 DESIGN OF SERVOMOTOR CONTROLLERS.

Unless agreed otherwise with the customer, each delivery includes:

- Delivery note
- Products pursuant to the purchase order
- Accessories to plug-in unit 51121 or 511 25
 - o Two connector sockets
- Optional accessories to controller 51122 and 511 26
 - o The set for enabling the installation behind the controllers of the series 511 02, 511 07 and 511 09 with the ordering number 035 464 015
- Accompanying technical documentation in Czech:
 - o Product quality and completeness certificate, which is also a warranty certificate
 - o Product manual

If it is established in the purchase contract or agreed otherwise, the following documentation can be delivered with the product:

- EU Declaration of conformity
- Test report about the seismic and the vibration qualification

PACKING

The products and accessories are delivered in packing ensuring resistance to the thermal effects and mechanical effects pursuant to controlled packing regulations.

TRANSPORT

The products can be transported on conditions complying with the set of combinations of classes IE 21 pursuant to EN 60721-3-2 (i.e. by airplanes and trucks; in premises that are ventilated and protected against climatic effects, heated overpressure cargo areas of the airplanes).

ORDERING

The purchase order shall identify

- Name
- Product ordering number
- Special design after an agreement with the manufacturer
- Number of pieces

STORAGE

The products can be stored on conditions complying with the set of conditions of classes IE 11 pursuant to EN 60721-3-1 at ambient temperature 0 to 35°C with relative air humidity 75% with max. content 22 g H₂O/m³ of dry air in places without a special threat of an attack with biological agents, with vibrations of low importance and not situated close to the sources of dust and sand. Air may not contain any other substances causing corrosion.

PURCHASE ORDER EXAMPLE

Servomotor controller
511 210 NK1
5 pcs

TABLE 1 - DESIGN OF SERVOMOTOR CONTROLLERS

SPECIFICATIONS		ORDERING NUMBER		
		511	xxx	NK1
With current feedback	Plug-in unit		210	
	In a box		220	
With galvanic separation	Plug-in unit		250	
	In a box		260	

INSTALLATION AND CONNECTION

INSTALLATION OF THE CONTROLLER

The actual plug-in units are inserted into tanks. They are connected with connectors.

The controllers in a box are connected on the wall with four screws pursuant to the dimensional drawing. They are connected by means of the terminal board.

To enable the installation behind the controllers of the series 511 02, 511 07, 511 09, it is possible to use the inserts pursuant to the drawing in Figure 2. The set of 2 inserts, 4 screws, 4 nuts and 4 washers is delivered under the ordering number 035 464 015.

ELECTRICAL CONNECTION

The electrical connection may be only realized by qualified workers.

The schemes of connection of the controllers are identified in Figure 4 and 5. For the connection of the input signals, Cu wires with insulation resistance of min. 20 MΩ are used. These wires may not be placed together with power wires. For the connection of the device to the power supply mains, insulated copper wires shall be used that are dimensioned pursuant to ČSN 33 2000-4-43 ed.2.

The installation at the device shall include a switch or a circuit breaker that enable to disconnect the device from the power supply mains.

After the connection, all outlets shall be sealed with a suitable sealing material, e.g. Colorplast.

COMMISSIONING

In case of the servomotor, it is expected that it is set-up in the manufacturing plant. The required range of the input control and feedback signal is selected pursuant to Table 3.

CONTROLLER SET-UP

The controller is switched to manual control and the maximum zone of proportionality is set-up with the potentiometer P. A milliammeter is connected serially to the terminal 33 (51) of the servomotor (plus on the wire to the controller). The servomotor is adjusted to the zero position and in this position, current shall be zero. If not, the induction transmitter at the servomotor shall be set-up mechanically till zero current is achieved. Then the servomotor is adjusted to the second limit position, in which current shall correspond to the end of the range. Possible small deviations in this position can be corrected with the potentiometer located in the induction transmitter. The servomotor is adjusted to the position, in which the current measured with the milliammeter equals to one half of the range of the feedback signal. 50 % signal, for which the controller is set-up, is brought to the control input of the controller. The controller is switched over to automatic control. The servomotor shall settle in the 50 % position.

In case of a change of the input signal, the position is changed. If the servomotor rotates regardless of the input signal to any limit position, the connection in the regulation loop is positive. In such a case, switch off the mains and replace the connections to the terminals 1, 2 (LO, LZ) of the servomotor.

Note:

After the adjustment, it is possible to increase amplification in the loop, as required, with the potentiometer P; it is necessary to consider stability. In case of using the signal 4 to 20 mA, it is possible to use the circuits for monitoring the failure of such signals. Monitoring is selected pursuant to TABLE 4.

TABLE 2 – DELIVERY OF THE CONTROLLERS FROM THE PLANT

The controllers in a box are delivered with the pre-set ranges:

Type	511 22	511 26
Input signal	4 to 20 mA	4 to 20 mA
Feedback	4 to 20 mA	4 to 20 mA
Monitoring of signal interruption	connected	connected

In case of all types, the tips A – B are not interconnected, i.e. manual control is included.

TABLE 3 - SELECTION OF RANGES OF THE CONTROLLERS

Selection of ranges of the controller is realized as follows:

- by interconnecting the tips on the signal connector for 511 21 and 511 25
- by interconnecting the soldering tips on the interconnecting bar for 511 22 and 511 26

Type		Signal	To interconnect
511 21 and 511 22	Feedback	4 to 20 mA	
	Input signal	4 to 20 mA	A8 - A10
		0 to 20 mA	A8 - A10, C8 - C6, A20 - C20
		0 to 10 V	A10 - C10, A20 - C20
511 25 and 511 26	Feedback	0 to 20 mA	A6 - A4
	Input signal	4 to 20 mA	A8 - A10, C20 - C18
		0 to 20 mA	A8 - A10, C8 - C6
		0 to 10 V	A10 - C10
	Feedback	4 to 20 mA	A8 - A10
	Input signal	4 to 20 mA	

TABLE 4 – MONITORING OF INTERRUPTION OF THE SIGNAL 4 to 20 mA

Type	Input signal	Feedback
511 21, 511 22	C26 – C24	A26 – C26
511 25, 511 26	C26 – C24 or S2	A26 – C26 or S1

Manual control is disabled by interconnecting the tips A - B on the power board pursuant to the following figure, the position B-C is only suspensory for the wire interconnection piece.

VIEW OF THE LOCATION OF TIPS A, B, C

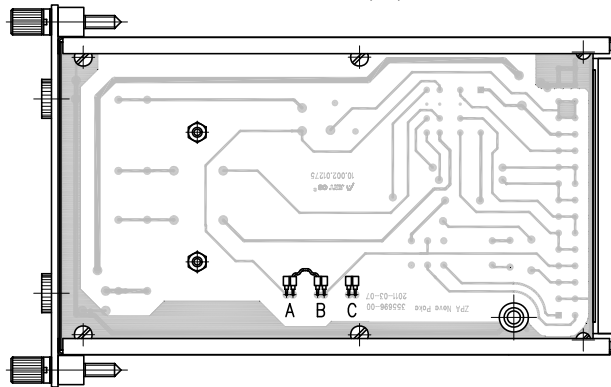

Warning!
A failure to comply with the instructions identified in this manual can result in erroneous function, reduced reliability or, as the case may be, even a failure or damage of the device without any right to a warranty repair.

OPERATION AND MAINTENANCE

The device does not require any operation and maintenance.

SPARE PARTS

The design of the device does not require any delivery of spare parts.

REPAIRS

The repairs shall be realized by the manufacturer.
The device shall be sent for repair in the original or equal package without accessories.

WARRANTY

The warranty period is 24 months from the receiving of the product by the customer, unless established otherwise in the contract. Rejection of defects shall be enforced in writing at the manufacturer within the warranty period. The rejecting side shall identify the product name, ordering and manufacturing numbers, date of issue and number of the delivery note, clear description of the occurring defect and the subject of the claim. If the rejecting side is invited to send the device for repair, it shall do so in the original package of the manufacturer and/or in another package ensuring safe transport.

The warranty shall not apply to defects caused by unauthorized intervention into the device, its forced mechanical damage or failure to comply with operation conditions of the product and the product manual.

DISABLING AND LIQUIDATION

The product and its package do not include any parts that could impact the environment.

The products that are withdrawn from operation, including their packages (with the exception of products marked as electrical equipment for the purposes of return withdrawal and separate salvage of electrical waste), may be disposed of to sorted or unsorted waste pursuant to the type of waste.

The manufacturer realizes free return withdrawal of marked electrical equipment (from 13.8.2005) from the consumer and points out the danger connected with their illegal disposal.

The package of the sensor can be recycled completely. Metal parts of the products are recycled, non-recyclable plastic materials and electrical waste and batteries shall be disposed of in compliance with the aforesaid Act.

FIGURE 3 - DRAWING OF LOCATION OF CONNECTORS, TERMINAL BOARD AND INTERCONNECTING BAR IN A BOX OF THE CONTROLLERS OF TYPE 511 22 AND 511 25

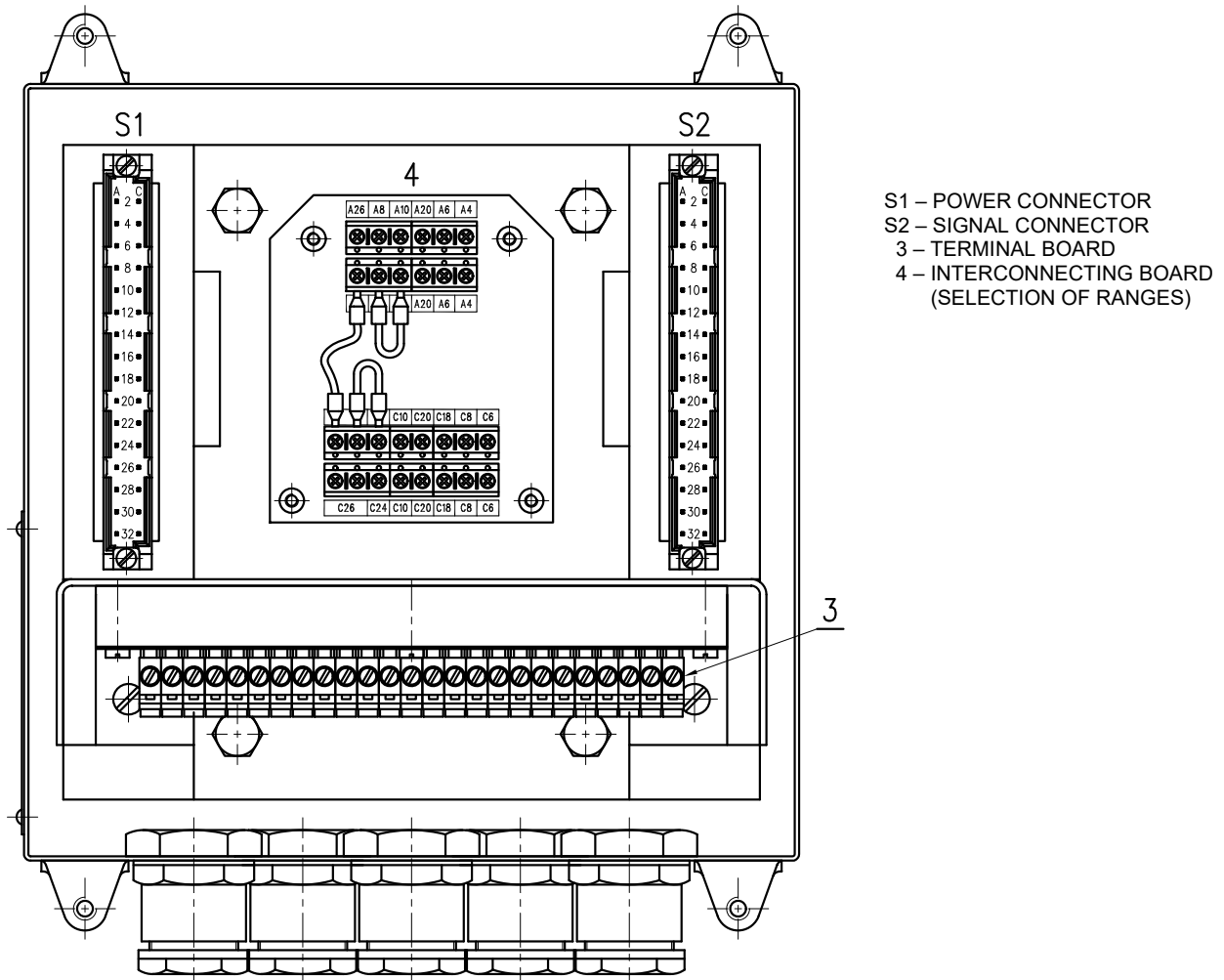

- S1 – POWER CONNECTOR
- S2 – SIGNAL CONNECTOR
- 3 – TERMINAL BOARD
- 4 – INTERCONNECTING BOARD
(SELECTION OF RANGES)

FIGURE 4 – SCHEME OF CONNECTION OF THE CONTROLLERS WITH SERVMOTOR IN DESIGN "CONNECTOR"

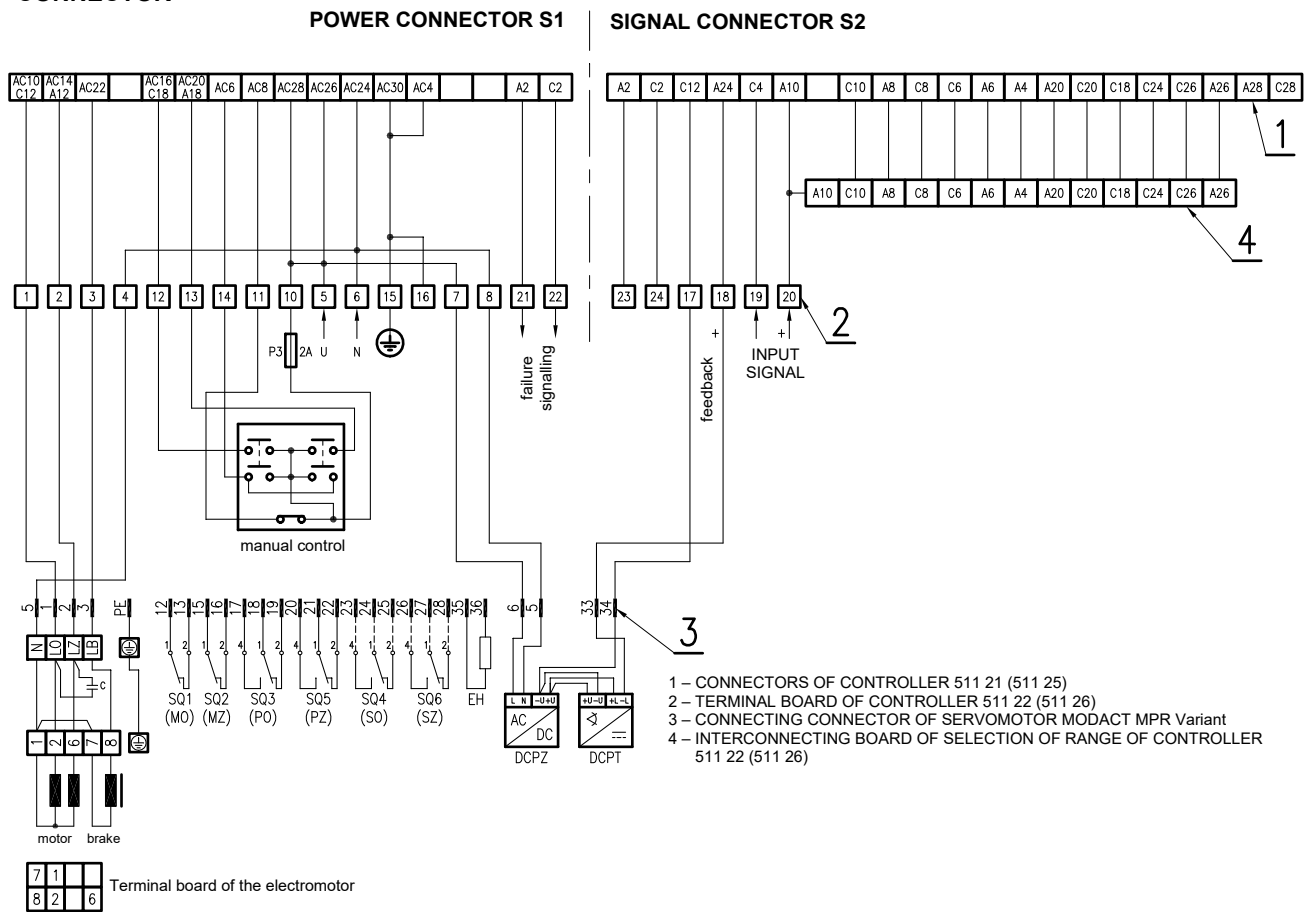

FIGURE 5 – SCHEME OF CONNECTION OF THE CONTROLLER WITH SERVMOTOR IN DESIGN "TERMINAL BOARD"

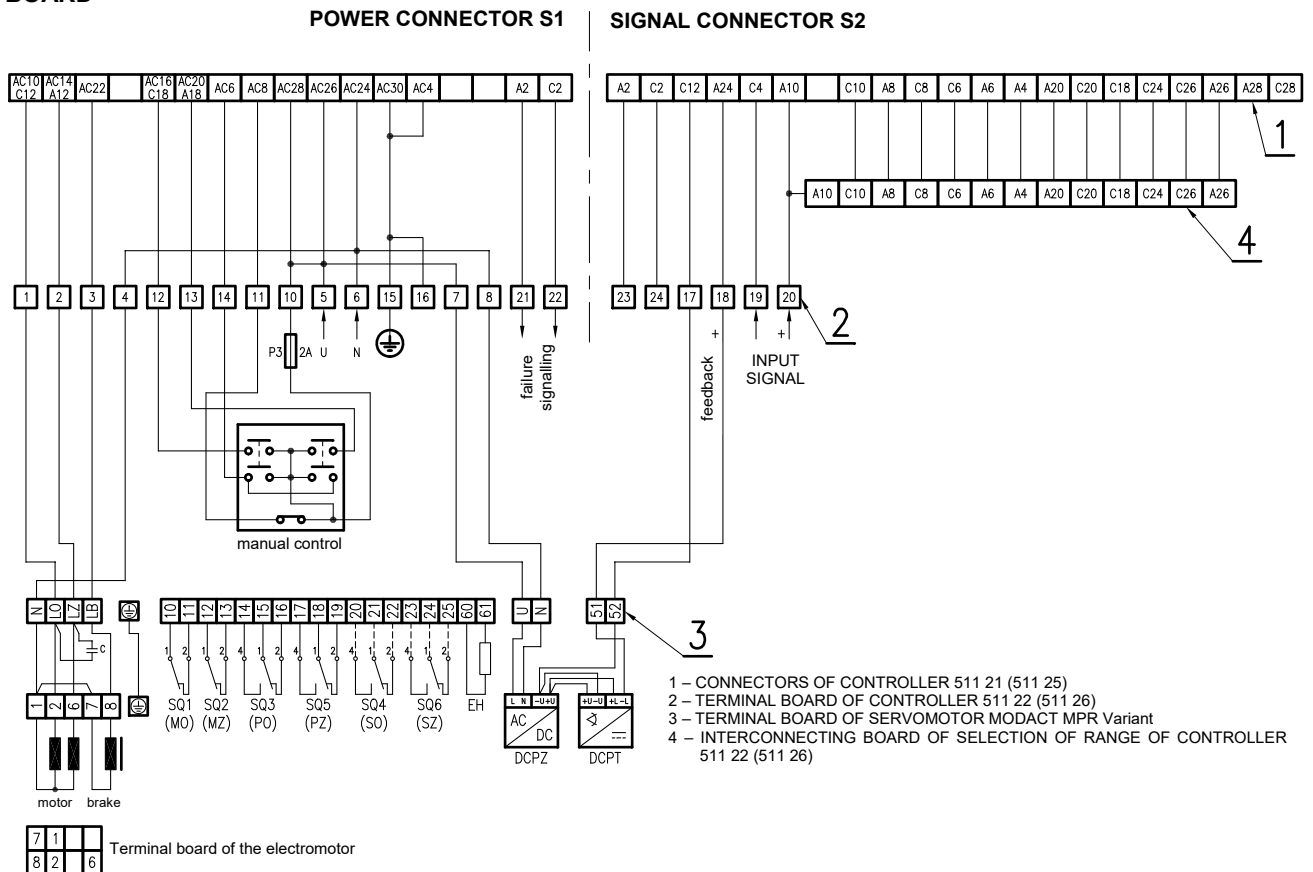

FIGURE 6 – BLOCK SCHEME OF THE CONTROLLERS 511 21 AND 511 22 WITH CURRENT FEEDBACK

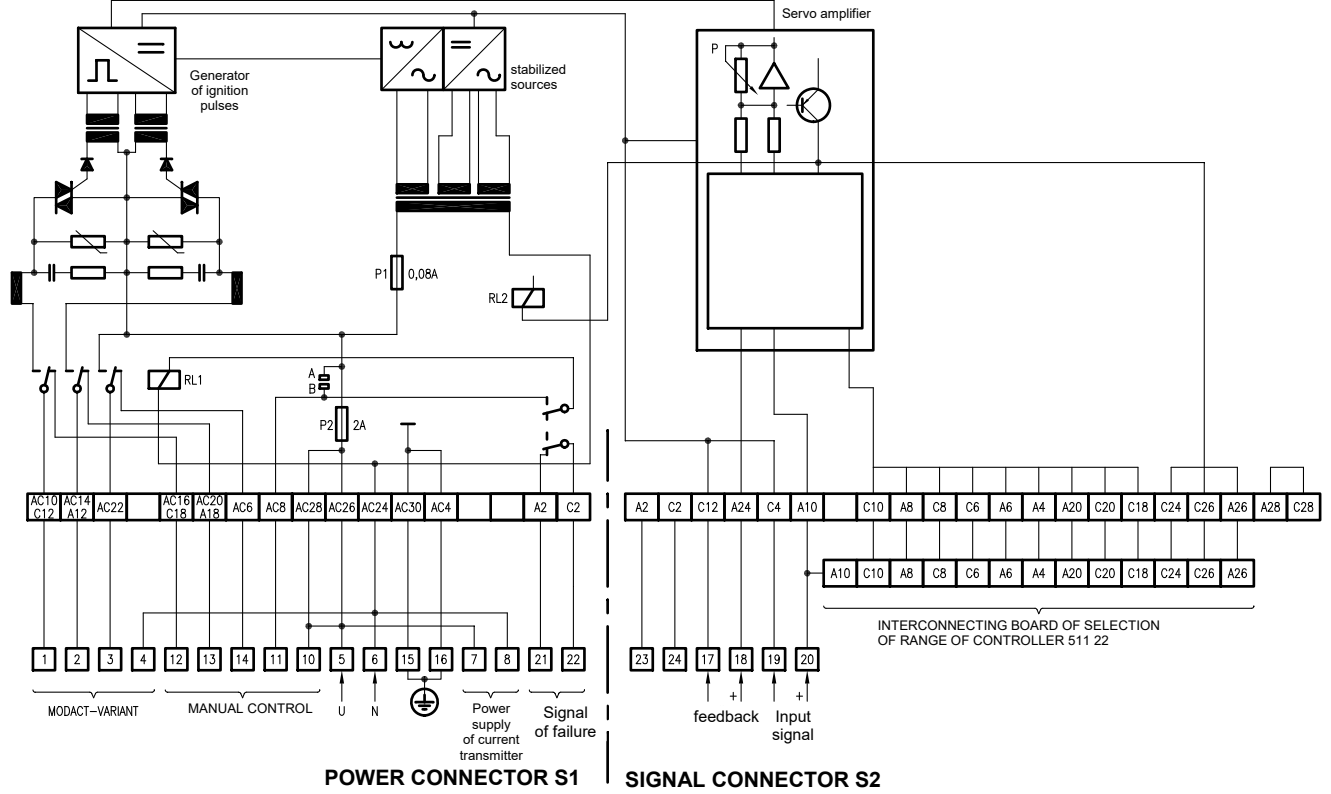
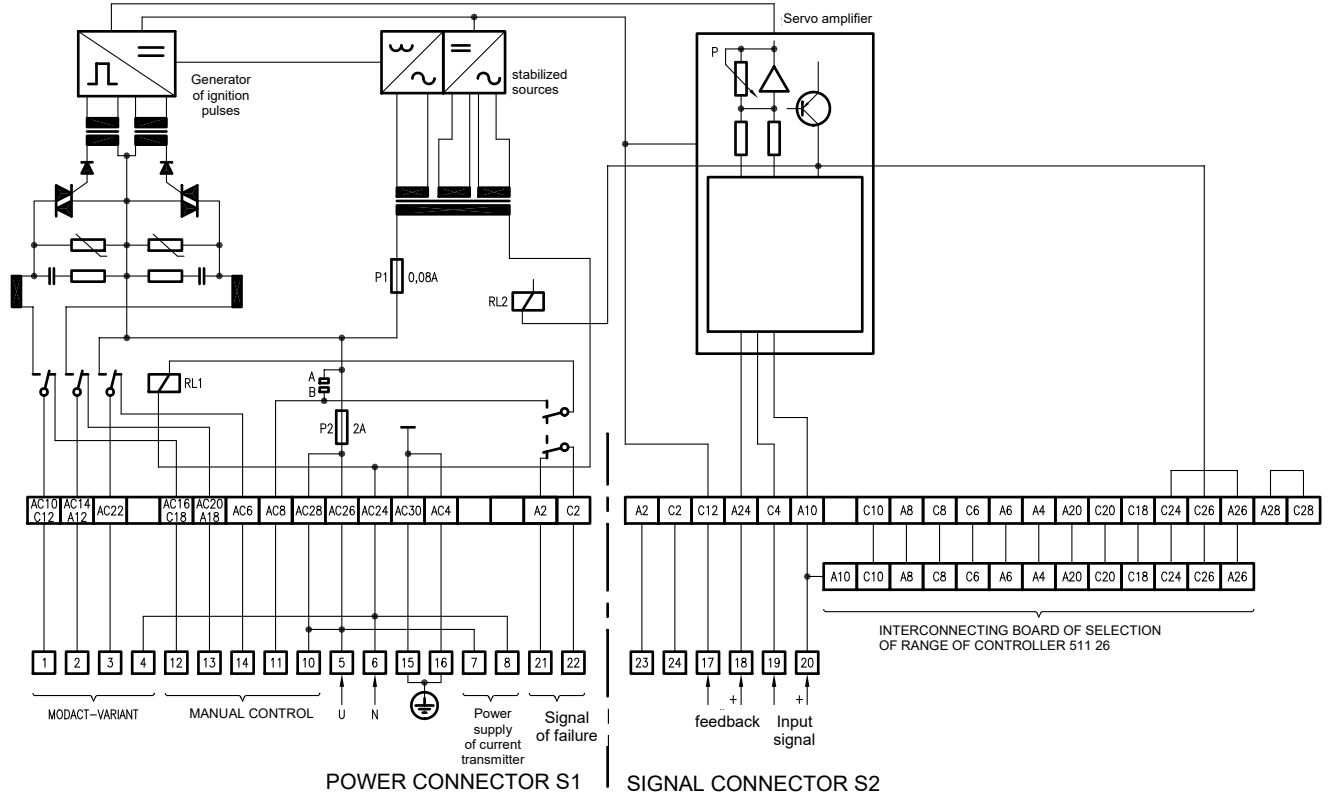

FIGURE 7 - BLOCK SCHEME OF THE CONTROLLERS 511 25 AND 511 26



June 2018

© ZPA Nová Paka, a.s.

