

Rosemount® 3144P Temperature Transmitter



For every responsibility you have, you are confronted with a number of challenges. You have aggressive production and quality targets, but inaccurate or unavailable temperature measurements create unscheduled downtime and off-spec products. Loops may be running in manual because you don't trust your temperature measurement, requiring the attention of your maintenance staff and costing money in lost production. Additionally, improving safety and complying with government and company regulations is made more difficult when you don't have the information or tools needed to prove your compliance.

That's why companies are coming to Emerson™ – because they know they need reliable measurements and visibility into their temperature measurements in order to address these challenges and achieve their business objectives. With the Rosemount 3144P Temperature Transmitter, you gain greater visibility into your temperature processes so you can improve safety, comply with regulations, make the most of your limited resources, and reach your production and quality targets. By leveraging the diagnostic capabilities and the unparalleled reliability and accuracy of the Rosemount 3144P, you can minimize off-spec product, reduce maintenance and downtime, improve the usage of your limited resources, and meet regulatory demands.

Rosemount 3144P Temperature Transmitter

Industry-leading temperature transmitter delivers unmatched field reliability and innovative process measurement solutions

- Superior accuracy and stability
- Dual and single sensor capability with universal sensor inputs (RTD, T/C, mV, ohms)
- Comprehensive sensor and process diagnostics offering
- SIL3 Capable: IEC 61508 certified by an accredited 3rd party agency for use in safety instrumented systems up to SIL 3 [Minimum requirement of single use (1oo1) for SIL 2 and redundant use (1oo2) for SIL 3]
- Dual-compartment housing
- Large LCD display
- 4-20 mA /HART® with Selectable Revisions (5 and 7)
- FOUNDATION™ fieldbus, compliant to ITK 6.0 and NE107 standards



Improve efficiency with best-in-class product specifications and capabilities

- Reduce maintenance and improve performance with industry leading accuracy and stability
- Improve measurement accuracy by 75% with Transmitter-Sensor Matching
- Ensure process health with system alerts and easy to use Device Dashboards
- Easily check device status and values on local LCD display with large percent range graph
- Achieve high reliability and installation ease with the industry's most rugged dual compartment design



Optimize measurement reliability with diagnostics designed for any protocol on any host system

- Thermocouple Degradation Diagnostic monitors the health of a thermocouple loop, enabling preventative maintenance
- Minimum and Maximum Temperature Tracking tracks and records temperature extremes of the process sensors and the ambient environment
- Sensor Drift Alert detects sensor drift and alerts the user
- The Hot Backup™ feature provides temperature measurement redundancy

Content

| | | | |
|---|---|----------------------------------|----|
| Rosemount 3144P Temperature Transmitter | 2 | Product Certifications | 16 |
| Transmitter Specifications | 8 | Dimensional drawings | 21 |

Explore the benefits of a complete point solution from Rosemount Temperature

- An “Assemble To Sensor” option enables Emerson to provide a complete point temperature solution, delivering an installation-ready transmitter and sensor assembly
- Emerson offers a selection of RTDs, thermocouples, and thermowells that bring superior durability and Rosemount reliability to temperature sensing, complementing the Rosemount Transmitter portfolio

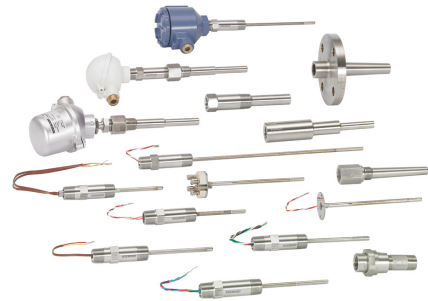

Experience global consistency and local support from numerous worldwide Rosemount Temperature manufacturing sites



- World-class manufacturing provides globally consistent product from every factory and the capacity to fulfill the needs of any project, large or small
- Experienced Instrumentation Consultants help select the right product for any temperature application and advise on best installation practices
- An extensive global network of Emerson service and support personnel can be on-site when and where they are needed

- Looking for a wireless temperature solution? For wireless applications that require superior performance and unmatched reliability, consider the **Rosemount 648 Wireless** Temperature Transmitter.
- A demanding high temperature application requires an innovative temperature solution. Pair the Rosemount 3144P Thermocouple Diagnostic with the **Rosemount 1075 High Temperature Thermocouple**.

Rosemount 3144P Temperature Transmitter



The industry-leading Rosemount 3144P Single Point Temperature Transmitter delivers unmatched field reliability and innovative process measurement solutions and diagnostics

Transmitter features include:

- Dual and Single Sensor Input Capabilities
- Transmitter-Sensor Matching (Option Code C2)
- Integral Transient Protector (Option Code T1)
- IEC 61508 Safety Certificate of Compliance (Option Code QT)
- Advanced Sensor and Process Diagnostics (Option Codes D01 and DA1)
- Large, Easy to Read LCD Display (Option Code M5)
- “Assemble to Sensor” option (Option Code XA)

Specification and selection of product materials, options, or components must be made by the purchaser of the equipment. See [page 8](#) for more information on Material Selection.

Table 1. Rosemount 3144P Temperature Transmitter Ordering Information

★ The Standard offering represents the most common options. The starred options (★) should be selected for best delivery. The Expanded offering is subject to additional delivery lead time.

| Model | Product description | | | |
|---------------------------|--|-----------------|--------------------|---|
| 3144P | Temperature Transmitter | | | |
| Housing style | | Material | Conduit entry size | |
| D1 | Field Mount Housing, Dual-Compartment Housing | Aluminum | 1/2-14 NPT | ★ |
| D2 | Field Mount Housing, Dual-Compartment Housing | Aluminum | M20 × 1.5 (CM20) | ★ |
| D3 | Field Mount Housing, Dual-Compartment Housing | Aluminum | PG 13.5 (PG11) | ★ |
| D4 | Field Mount Housing, Dual-Compartment Housing | Aluminum | JIS G 1/2 | ★ |
| D5 | Field Mount Housing, Dual-Compartment Housing | Stainless Steel | 1/2-14 NPT | ★ |
| D6 | Field Mount Housing, Dual-Compartment Housing | Stainless Steel | M20 × 1.5 (CM20) | ★ |
| D7 | Field Mount Housing, Dual-Compartment Housing | Stainless Steel | PG 13.5 (PG11) | ★ |
| D8 | Field Mount Housing, Dual-Compartment Housing | Stainless Steel | JIS G 1/2 | ★ |
| Transmitter output | | | | |
| A | 4-20 mA with digital signal based on HART protocol | | | ★ |
| F | FOUNDATION fieldbus digital signal (includes 3 AI function block and Backup Link Active Scheduler) | | | ★ |
| Measurement configuration | | | | |
| 1 | Single-Sensor Input | | | ★ |
| 2 | Dual-Sensor Input | | | ★ |

Table 1. Rosemount 3144P Temperature Transmitter Ordering Information

★ The Standard offering represents the most common options. The starred options (★) should be selected for best delivery. The Expanded offering is subject to additional delivery lead time.

| Product certifications | | |
|-------------------------------|---|---|
| NA | No Approval | ★ |
| E5 | FM Explosion-proof, Dust Ignition-Proof, and Non-incendive approval | ★ |
| I5 ⁽¹⁾ | FM Intrinsically Safe and Non-incendive (includes standard IS and FISCO for fieldbus units) | ★ |
| K5 ⁽¹⁾ | FM IS, Non-incendive & Explosion-proof combo (includes standard IS and FISCO for fieldbus units) | ★ |
| KB ⁽¹⁾ | FM and CSA IS, Explosion-proof, and Non-incendive combo (includes standard IS and FISCO for FF units) | ★ |
| I6 ⁽¹⁾ | CSA Intrinsically Safe/FISCO and Division 2 (includes standard IS and FISCO for fieldbus units) | ★ |
| K6 ⁽¹⁾ | CSA IS, FISCO Division 2 and Explosion-proof combo (includes standard IS, FISCO for fieldbus units) | ★ |
| E1 | ATEX Flameproof approval | ★ |
| N1 | ATEX type n approval | ★ |
| I1 ⁽¹⁾ | ATEX intrinsic safety approval (includes standard IS and FISCO for fieldbus units) | ★ |
| K1 ⁽¹⁾ | ATEX IS, Flameproof, Dust Ignition-Proof and type n combo (includes standard IS and FISCO for fieldbus units) | ★ |
| ND | ATEX Dust Ignition-Proof approval | ★ |
| KA ⁽¹⁾ | ATEX/CSA intrinsic safety, Explosion-proof combo (includes standard IS and FISCO for fieldbus units) | ★ |
| E7 | IECEx Flameproof approval | ★ |
| N7 | IECEx Type 'n' approval | ★ |
| I7 ⁽¹⁾⁽²⁾ | IECEx Intrinsic Safety | ★ |
| K7 ⁽¹⁾⁽²⁾ | IECEx Intrinsic Safety, Flameproof, Dust Ignition-Proof and Type n combination | ★ |
| E2 ⁽²⁾ | INMETRO Flameproof | ★ |
| I2 ⁽²⁾⁽⁶⁾ | INMETRO Intrinsic safety | ★ |
| E4 ⁽²⁾ | TIIS Flameproof approval | ★ |
| E3 ⁽²⁾ | NEPSI Flameproof approval | ★ |
| I3 ⁽¹⁾⁽²⁾ | NEPSI Intrinsic safety | ★ |
| KM | Technical Regulations Customs Union (EAC) Flameproof, Intrinsic Safety | ★ |
| IM | Technical Regulations Customs Union (EAC) Intrinsic Safety | ★ |
| EM | Technical Regulations Customs Union (EAC) Flameproof | ★ |

Options (include with selected model number)

| PlantWeb[®] control functionality | | |
|---|--|---|
| A01 | FOUNDATION fieldbus Advanced Control Function Block Suite | ★ |
| PlantWeb advanced diagnostic functionality | | |
| D01 | FOUNDATION fieldbus Sensor and Process Diagnostic Suite: Thermocouple Diagnostic, Min/Max Tracking | ★ |
| DA1 | HART Sensor and Process Diagnostic Suite: Thermocouple Diagnostic, Min/Max Tracking | ★ |
| Enhanced performance | | |
| P8 ⁽³⁾ | Enhanced Transmitter Accuracy | ★ |

Table 1. Rosemount 3144P Temperature Transmitter Ordering Information

★ The Standard offering represents the most common options. The starred options (★) should be selected for best delivery. The Expanded offering is subject to additional delivery lead time.

| Mounting bracket | | |
|---|---|---|
| B4 | “U” Mounting Bracket for 2-inch pipe mounting - All SST | ★ |
| B5 | “L” Mounting Bracket for 2-inch pipe or panel mounting - All SST | ★ |
| Display | | |
| M5 | LCD Display | ★ |
| External ground | | |
| G1 | External Ground Lug Assembly | ★ |
| Transient protector | | |
| T1 ⁽⁴⁾ | Integral Transient Protector | ★ |
| Software configuration | | |
| C1 ⁽⁵⁾ | Custom Configuration of Date, Descriptor and Message (requires CDS with order) | ★ |
| Line filter | | |
| F5 | 50 Hz Line Voltage Filter | ★ |
| Alarm level configuration | | |
| A1 ⁽⁴⁾ | NAMUR Alarm and Saturation Levels, High Alarm | ★ |
| CN | NAMUR Alarm and Saturation Levels, Low Alarm | ★ |
| Low alarm | | |
| C8 | Low Alarm (Standard Rosemount Alarm and Saturation Values) | ★ |
| Sensor trim | | |
| C2 | Transmitter-Sensor Matching – Trim to PT100 RTD Calibration Schedule (CVD constants) | ★ |
| C7 | Trim to Non-Standard Sensor (Special Sensor–Customer must provide sensor information) | |
| 5-point calibration | | |
| C4 | 5-Point Calibration (requires the Q4 option code to generate a Calibration Certificate) | ★ |
| Calibration certification | | |
| Q4 | Calibration Certificate (3-Point Calibration) | ★ |
| QG | Calibration Certificate and GOST Verification Certificate | ★ |
| QP | Calibration Certificate and Tamper Evident Seal | ★ |
| Dual-input custom configuration (only with measurement type option code 2) | | |
| U1 ⁽⁵⁾ | Hot Backup | ★ |
| U2 ⁽⁵⁾ | Average temperature with Hot Backup and Sensor Drift Alert – warning mode | ★ |
| U3 ⁽⁶⁾ | Average temperature with Hot Backup and Sensor Drift Alert – alarm mode | ★ |
| U5 | Differential temperature | ★ |
| U6 ⁽⁵⁾ | Average temperature | ★ |

Table 1. Rosemount 3144P Temperature Transmitter Ordering Information

★ The Standard offering represents the most common options. The starred options (★) should be selected for best delivery. The Expanded offering is subject to additional delivery lead time.

| Dual-input custom configuration (only with measurement type option code 2) | | |
|---|--|---|
| U7 ⁽⁵⁾ | First good temperature | ★ |
| U4 | Two independent sensors | |
| Customer transfer | | |
| D3 ⁽⁵⁾⁽⁶⁾ | Custody Transfer Approval (Canada) | |
| D4 ⁽⁶⁾ | MID Custody Transfer (Europe) | |
| Quality certification for safety | | |
| QS | Prior-use certificate of FMEDA data (HART only) | ★ |
| QT | Safety-certified to IEC 61508 with certificate of FMEDA data (HART only) | ★ |
| Shipboard certification | | |
| SBS | American Bureau of Shipping (ABS) Type Approval | ★ |
| SBV | Bureau Veritas (BV) Type Approval | ★ |
| SDN | Det Norske Veritas (DNV) Type Approval | ★ |
| SLL | Lloyd's Register (LR) Type Approval | ★ |
| Conduit electrical connector | | |
| GE ⁽⁶⁾ | M12, 4-pin, Male Connector (eurofast [®]) | ★ |
| GM ⁽⁶⁾ | A size Mini, 4-pin, Male Connector (minifast [®]) | ★ |
| HART revision configuration | | |
| HR7 | Configured for HART Revision 7 | ★ |
| Assemble to options | | |
| XA | Sensor Specified Separately and Assembled to Transmitter | ★ |
| Extended product warranty | | |
| WR3 | 3-year limited warranty | ★ |
| WR5 | 5-year limited warranty | ★ |
| Typical model number: 3144P D1 A 1 E5 B4 M5 | | |

(1) When IS approval is ordered on a FOUNDATION fieldbus, both standard IS and FISCO IS approvals apply. The device label is marked appropriately.

(2) Consult factory for availability when ordering with HART or FOUNDATION fieldbus models.

(3) Enhanced accuracy only applies to RTDs, however the option can be ordered with any sensor type.

(4) Ambient temperature effect specification valid over minimum temperature span of 28 °C (50 °F).

(5) Consult factory for availability when ordering with FOUNDATION fieldbus models.

(6) Available with Intrinsically Safe approvals only. For FM Intrinsically Safe or non-incendive approval (option code I5), install in accordance with Rosemount drawing 03151-1009 to maintain 4X rating.

Transmitter Specifications

HART and FOUNDATION fieldbus

Functional specifications

Inputs

User-selectable. See [Table 2 on page 9](#) for sensor options.

Output

2-wire device with either 4–20 mA/HART, linear with temperature or input, or completely digital output with FOUNDATION fieldbus communication (ITK 6.0.1 compliant).

Isolation

Input/output isolation specified to 500 Vdc (500 Vrms 707 V peak) at 50/60 Hz.

Humidity limits

0–99% relative humidity.

Update time

Approximately 0.5 seconds for a single sensor (1 second for dual sensors).

Physical specifications

Material selection

Emerson provides a variety of Rosemount product with various product options and configurations including materials of construction that can be expected to perform well in a wide range of applications. The Rosemount product information presented is intended as a guide for the purchaser to make an appropriate selection for the application. It is the purchaser's sole responsibility to make a careful analysis of all process parameters (such as all chemical components, temperature, pressure, flow rate, abrasives, contaminants, etc.), when specifying product, materials, options and components for the particular application. Emerson Process Management is not in a position to evaluate or guarantee the compatibility of the process fluid or other process parameters with the product, options, configuration or materials of construction selected.

Conformance to specification ($\pm 3\sigma$ [Sigma])

Technology leadership, advanced manufacturing techniques, and statistical process control ensure specification conformance to at least $\pm 3\sigma$.

Conduit connections

The standard field mount housing has $1/2$ –14 NPT conduit entries. Additional conduit entry types are available, including PG13.5 (PG11), M20 \times 1.5 (CM20), or JIS G $1/2$. When any of these additional entry types are ordered, adapters are placed in the standard field housing so these alternative conduit types fit correctly. See “[Dimensional drawings](#)” on [page 21](#) for dimensions.

Materials of construction

Electronics housing

Low-copper aluminum or CF-8M (cast version of 316 Stainless Steel)

Paint

Polyurethane

Cover O-rings

Buna-N

Mounting

Transmitters may be attached directly to the sensor. Optional mounting brackets (codes B4 and B5) allow for remote mounting. See “[Optional Transmitter Mounting Brackets](#)” on [page 23](#).

Weight

| Aluminum ⁽¹⁾ | Stainless steel ⁽¹⁾ |
|-------------------------|--------------------------------|
| 3.1 lb (1.4 kg) | 7.8 lb (3.5 kg) |

(1) Add 0.5 lb (0.2 kg) for local display or 1.0 lb (0.5 kg) for bracket options.

Enclosure ratings

Type 4X

IP66 and IP68

Stability

- RTDs: - $\pm 0.1\%$ of reading or 0.1 °C, whichever is greater, for 24 months.
- Thermocouples: - $\pm 0.1\%$ of reading or 0.1 °C, whichever is greater, for 12 months.

5 Year stability

- RTDs: - $\pm 0.25\%$ of reading or $0.25\text{ }^{\circ}\text{C}$, whichever is greater, for 5 years.
- Thermocouples: - $\pm 0.5\%$ of reading or $0.5\text{ }^{\circ}\text{C}$, whichever is greater, for 5 years.

Vibration effect

Tested to the following with no effect on performance per IEC 60770-1, 1999:

| Frequency | Acceleration |
|------------|---------------------------|
| 10–60 Hz | 0.21 mm peak displacement |
| 60–2000 Hz | 3 g |

Self calibration

The analog-to-digital measurement circuitry automatically self-calibrates for each temperature update by comparing the dynamic measurement to extremely stable and accurate internal reference elements.

RFI effect

Worst case RFI effect is equivalent to the transmitter's nominal accuracy specification, according to [Table 2 on page 9](#), when tested in accordance with IEC 61000-4-3, 30 V/m (HART)/20 V/m (HART T/C)/10 V/m (FOUNDATION fieldbus), 80 to 1000 MHz, with unshielded cable.

CE electromagnetic compatibility compliance testing

The Rosemount 3144P meets or exceeds all requirements listed under IEC 61326: 2006.

Table 2. Transmitter Accuracy

| Sensor options | Sensor reference | Input ranges | | Minimum span ⁽¹⁾ | | Digital accuracy ⁽²⁾ | | Enhanced accuracy ⁽³⁾ | D/A accuracy ⁽⁴⁾⁽⁵⁾ |
|--------------------------------|------------------------------|--------------------|--------------------|-----------------------------|--------------------|---------------------------------|--------------------|----------------------------------|--------------------------------|
| | | $^{\circ}\text{C}$ | $^{\circ}\text{F}$ | $^{\circ}\text{C}$ | $^{\circ}\text{F}$ | $^{\circ}\text{C}$ | $^{\circ}\text{F}$ | $^{\circ}\text{C}$ | |
| 2-, 3-, 4-wire RTDs | | | | | | | | | |
| Pt 100 ($\alpha = 0.00385$) | IEC 751 | -200 to 850 | -328 to 1562 | 10 | 18 | ± 0.10 | ± 0.18 | ± 0.08 | $\pm 0.02\%$ of span |
| Pt 200 ($\alpha = 0.00385$) | IEC 751 | -200 to 850 | -328 to 1562 | 10 | 18 | ± 0.22 | ± 0.40 | ± 0.176 | $\pm 0.02\%$ of span |
| Pt 500 ($\alpha = 0.00385$) | IEC 751 | -200 to 850 | -328 to 1562 | 10 | 18 | ± 0.14 | ± 0.25 | ± 0.112 | $\pm 0.02\%$ of span |
| Pt 1000 ($\alpha = 0.00385$) | IEC 751 | -200 to 300 | -328 to 572 | 10 | 18 | ± 0.10 | ± 0.18 | ± 0.08 | $\pm 0.02\%$ of span |
| Pt 100 ($\alpha = 0.003916$) | JIS 1604 | -200 to 645 | -328 to 1193 | 10 | 18 | ± 0.10 | ± 0.18 | ± 0.08 | $\pm 0.02\%$ of span |
| Pt 200 ($\alpha = 0.003916$) | JIS 1604 | -200 to 645 | -328 to 1193 | 10 | 18 | ± 0.22 | ± 0.40 | ± 0.176 | $\pm 0.02\%$ of span |
| Ni 120 | Edison Curve No. 7 | -70 to 300 | -94 to 572 | 10 | 18 | ± 0.08 | ± 0.14 | ± 0.064 | $\pm 0.02\%$ of span |
| Cu 10 | Edison Copper Winding No. 15 | -50 to 250 | -58 to 482 | 10 | 18 | ± 1.00 | ± 1.80 | ± 0.8 | $\pm 0.02\%$ of span |
| Pt 50 ($\alpha = 0.00391$) | GOST 6651-94 | -200 to 550 | -328 to 1022 | 10 | 18 | ± 0.20 | ± 0.36 | ± 0.16 | $\pm 0.02\%$ of span |
| Pt 100 ($\alpha = 0.00391$) | GOST 6651-94 | -200 to 550 | -328 to 1022 | 10 | 18 | ± 0.10 | ± 0.18 | ± 0.08 | $\pm 0.02\%$ of span |

External ground screw assembly

The external ground screw assembly can be ordered by specifying code G1. However, some approvals include the ground screw assembly in the transmitter shipment, hence it is not necessary to order code G1. The table below identifies which approval options include the external ground screw assembly.

| Approval type | External ground screw assembly included? ⁽¹⁾ |
|--|---|
| E5, I1, I2, I5, I6, I7, K5, K6, KB, NA | No—Order option code G1 |
| E1, E2, E3, E4, E7, K1, K7, KA, N1, N7, ND, NF | Yes |

(1) The parts contained with the G1 option are included with the Integral Protector option code T1. When ordering T1, the G1 option code does not need to be ordered separately.

Hardware tag

- No charge
- 2 lines of 28 characters (56 characters total)
- Tags are stainless steel
- Permanently attached to transmitter
- Character height is $1/16$ -in. (1.6mm)
- A wire-on tag is available upon request. 5 lines of 12 characters (60 characters total)

Software tag

- HART transmitter can store up to 8 characters in HART 5 mode and 32 characters in HART 7 mode. FOUNDATION fieldbus transmitters can store up to 32 characters.
- Can be ordered with different software and hardware tags.
- If no software tag characters are specified, the first 8 characters of the hardware tag are the default.

Table 2. Transmitter Accuracy

| Sensor options | Sensor reference | Input ranges | | Minimum span ⁽¹⁾ | | Digital accuracy ⁽²⁾ | | Enhanced accuracy ⁽³⁾ | D/A accuracy ⁽⁴⁾⁽⁵⁾ |
|------------------------------------|-----------------------------|----------------|--------------|-----------------------------|----|---------------------------------|------------|----------------------------------|--------------------------------|
| | | °C | °F | °C | °F | °C | °F | °C | |
| 2-, 3-, 4-wire RTDs | | | | | | | | | |
| Cu 50 ($\alpha=0.00426$) | GOST 6651-94 | -50 to 200 | -58 to 392 | 10 | 18 | ± 0.34 | ± 0.61 | ± 0.272 | $\pm 0.02\%$ of span |
| Cu 50 ($\alpha=0.00428$) | GOST 6651-94 | -185 to 200 | -301 to 392 | 10 | 18 | ± 0.34 | ± 0.61 | ± 0.272 | $\pm 0.02\%$ of span |
| Cu 100 ($\alpha=0.00426$) | GOST 6651-94 | -50 to 200 | -58 to 392 | 10 | 18 | ± 0.17 | ± 0.31 | ± 0.136 | $\pm 0.02\%$ of span |
| Cu 100 ($\alpha=0.00428$) | GOST 6651-94 | -185 to 200 | -301 to 392 | 10 | 18 | ± 0.17 | ± 0.31 | ± 0.136 | $\pm 0.02\%$ of span |
| Thermocouples⁽⁶⁾ | | | | | | | | | |
| Type B ⁽⁷⁾ | NIST Monograph 175, IEC 584 | 100 to 1820 | 212 to 3308 | 25 | 45 | ± 0.75 | ± 1.35 | N/A | $\pm 0.02\%$ of span |
| Type E | NIST Monograph 175, IEC 584 | -50 to 1000 | -58 to 1832 | 25 | 45 | ± 0.20 | ± 0.36 | N/A | $\pm 0.02\%$ of span |
| Type J | NIST Monograph 175, IEC 584 | -180 to 760 | -292 to 1400 | 25 | 45 | ± 0.25 | ± 0.45 | N/A | $\pm 0.02\%$ of span |
| Type K ⁽⁸⁾ | NIST Monograph 175, IEC 584 | -180 to 1372 | -292 to 2501 | 25 | 45 | ± 0.25 | ± 0.45 | N/A | $\pm 0.02\%$ of span |
| Type N | NIST Monograph 175, IEC 584 | -200 to 1300 | -328 to 2372 | 25 | 45 | ± 0.40 | ± 0.72 | N/A | $\pm 0.02\%$ of span |
| Type R | NIST Monograph 175, IEC 584 | 0 to 1768 | 32 to 3214 | 25 | 45 | ± 0.60 | ± 1.08 | N/A | $\pm 0.02\%$ of span |
| Type S | NIST Monograph 175, IEC 584 | 0 to 1768 | 32 to 3214 | 25 | 45 | ± 0.50 | ± 0.90 | N/A | $\pm 0.02\%$ of span |
| Type T | NIST Monograph 175, IEC 584 | -200 to 400 | -328 to 752 | 25 | 45 | ± 0.25 | ± 0.45 | N/A | $\pm 0.02\%$ of span |
| DIN Type L | DIN 43710 | -200 to 900 | -328 to 1652 | 25 | 45 | ± 0.35 | ± 0.63 | N/A | $\pm 0.02\%$ of span |
| DIN Type U | DIN 43710 | -200 to 600 | -328 to 1112 | 25 | 45 | ± 0.35 | ± 0.63 | N/A | $\pm 0.02\%$ of span |
| Type W5Re/W26Re | ASTM E 988-96 | 0 to 2000 | 32 to 3632 | 25 | 45 | ± 0.70 | ± 1.26 | N/A | $\pm 0.02\%$ of span |
| GOST Type L | GOST R 8.585-2001 | -200 to 800 | -392 to 1472 | 25 | 45 | ± 0.25 | ± 0.45 | N/A | $\pm 0.02\%$ of span |
| Other input types | | | | | | | | | |
| Millivolt Input | | -10 to 100 mV | | 3 mV | | ± 0.015 mV | | N/A | $\pm 0.02\%$ of span |
| 2-, 3-, 4-wire Ohm Input | | 0 to 2000 ohms | | 20 ohm | | ± 0.35 ohm | | N/A | $\pm 0.02\%$ of span |

(1) No minimum or maximum span restrictions within the input ranges. Recommended minimum span will hold noise within accuracy specification with damping at zero seconds.

(2) Digital accuracy: Digital output can be accessed by the Field Communicator.

(3) Enhanced accuracy can be ordered using the P8 Model Code.

(4) Total Analog accuracy is the sum of digital and D/A accuracies.

(5) Applies to HART/4-20 mA devices.

(6) Total digital accuracy for thermocouple measurement: sum of digital accuracy $+0.25$ °C (0.45 °F) (cold junction accuracy).

(7) Digital accuracy for NIST Type B is ± 3.0 °C (± 5.4 °F) from 100 to 300 °C (212 to 572 °F).

(8) Digital accuracy for NIST Type K is ± 0.50 °C (± 0.9 °F) from -180 to -90 °C (-292 to -130 °F).

Reference accuracy example (HART only)

When using a Pt 100 ($\alpha = 0.00385$) sensor input with a 0 to 100 °C span: Digital Accuracy would be ± 0.10 °C, D/A accuracy would be $\pm 0.02\%$ of 100 °C or ± 0.02 °C, Total = ± 0.12 °C.

Differential capability exists between any two sensor types (dual-sensor option)

For all differential configurations, the input range is X to Y where:

- X = Sensor 1 minimum – Sensor 2 maximum and
- Y = Sensor 1 maximum – Sensor 2 minimum

Digital accuracy for differential configurations (dual-sensor option, HART only)

- Sensor types are similar (e.g., both RTDs or both T/Cs): Digital Accuracy = 1.5 times worst case accuracy of either sensor type
- Sensor types are dissimilar (e.g., one RTD, one T/C): Digital Accuracy = Sensor 1 Accuracy + Sensor 2 Accuracy

Ambient temperature effect

Transmitters may be installed in locations where the ambient temperature is between -40 and 85 °C (-40 and 185 °F). To maintain excellent accuracy performance, each transmitter is individually characterized over this ambient temperature range at the factory.

Table 3. Ambient Temperature Effect on Digital Accuracy

| Sensor options | Sensor reference | Effect per 1.0 °C (1.8 °F) change in ambient ⁽¹⁾⁽²⁾ | Input temperature (T) | D/A effect ⁽³⁾ |
|--------------------------------|------------------------------|--|---|---------------------------|
| 2-, 3-, or 4-wire RTDs | | | | |
| Pt 100 ($\alpha = 0.00385$) | IEC 751 | 0.0015 °C (0.0027 °F) | Entire Sensor Input Range | 0.001% of span |
| Pt 200 ($\alpha = 0.00385$) | IEC 751 | 0.0023 °C (0.00414 °F) | Entire Sensor Input Range | 0.001% of span |
| Pt 500 ($\alpha = 0.00385$) | IEC 751 | 0.0015 °C (0.0027 °F) | Entire Sensor Input Range | 0.001% of span |
| Pt 1000 ($\alpha = 0.00385$) | IEC 751 | 0.0015 °C (0.0027 °F) | Entire Sensor Input Range | 0.001% of span |
| Pt 100 ($\alpha = 0.003916$) | JIS 1604 | 0.0015 °C (0.0027 °F) | Entire Sensor Input Range | 0.001% of span |
| Pt 200 ($\alpha = 0.003916$) | JIS 1604 | 0.0023 °C (0.00414 °F) | Entire Sensor Input Range | 0.001% of span |
| Ni 120 | Edison Curve No. 7 | 0.0010 °C (0.0018 °F) | Entire Sensor Input Range | 0.001% of span |
| Cu 10 | Edison Copper Winding No. 15 | 0.015 °C (0.027 °F) | Entire Sensor Input Range | 0.001% of span |
| Pt 50 ($\alpha = 0.00391$) | GOST 6651-94 | 0.003 °C (0.0054 °F) | Entire Sensor Input Range | 0.001% of span |
| Pt 100 ($\alpha = 0.00391$) | GOST 6651-94 | 0.0015 °C (0.0027 °F) | Entire Sensor Input Range | 0.001% of span |
| Cu 50 ($\alpha = 0.00426$) | GOST 6651-94 | 0.003 °C (0.0054 °F) | Entire Sensor Input Range | 0.001% of span |
| Cu 50 ($\alpha = 0.00428$) | GOST 6651-94 | 0.003 °C (0.0054 °F) | Entire Sensor Input Range | 0.001% of span |
| Cu 100 ($\alpha = 0.00426$) | GOST 6651-94 | 0.0015 °C (0.0027 °F) | Entire Sensor Input Range | 0.001% of span |
| Cu 100 ($\alpha = 0.00428$) | GOST 6651-94 | 0.0015 °C (0.0027 °F) | Entire Sensor Input Range | 0.001% of span |
| Thermocouples | | | | |
| Type B | NIST Monograph 175, IEC 584 | 0.014 °C 0.029 °C – 0.0021% of (T – 300) 0.046 °C – 0.0086% of (T – 100) | $T \geq 1000$ °C $300 \text{ °C} \leq T < 1000$ °C $100 \text{ °C} \leq T < 300$ °C | 0.001% of span |
| Type E | NIST Monograph 175, IEC 584 | 0.004 °C + 0.00043% of T | N/A | 0.001% of span |
| Type J | NIST Monograph 175, IEC 584 | 0.004 °C + 0.00029% of T 0.004 °C + 0.0020% of abs. val. T | $T \geq 0$ °C $T < 0$ °C | 0.001% of span |
| Type K | NIST Monograph 175, IEC 584 | 0.005 °C + 0.00054% of T 0.005 °C + 0.0020% of abs. val. T | $T \geq 0$ °C $T < 0$ °C | 0.001% of span |
| Type N | NIST Monograph 175, IEC 584 | 0.005 °C + 0.00036% of T | All | 0.001% of span |
| Types R | NIST Monograph 175, IEC 584 | 0.015 °C 0.021 °C – 0.0032% of T | $T \geq 200$ °C $T < 200$ °C | 0.001% of span |
| Types S | NIST Monograph 175, IEC 584 | 0.015 °C 0.021 °C – 0.0032% of T | $T \geq 200$ °C $T < 200$ °C | 0.001% of span |
| Type T | NIST Monograph 175, IEC 584 | 0.005 °C 0.005 °C + 0.0036% of abs. val. T | $T \geq 0$ °C $T < 0$ °C | 0.001% of span |
| DIN Type L | DIN 43710 | 0.0054 °C + 0.00029% of R 0.0054 °C + 0.0025% of abs. val. T | $T \geq 0$ °C $T < 0$ °C | 0.001% of span |
| DIN Type U | DIN 43710 | 0.0064 °C 0.0064 °C + 0.0043% of abs. val. T | $T \geq 0$ °C $T < 0$ °C | 0.001% of span |

Table 3. Ambient Temperature Effect on Digital Accuracy

| Thermocouples | | | | |
|--------------------------|-------------------|---------------------------------------|---------------------------|----------------|
| Type W5Re/W26Re | ASTM E 988-96 | 0.016 °C 0.023 °C + 0.0036% of T | T ≥ 200 °C T < 200 °C | 0.001% of span |
| GOST Type L | GOST R 8.585-2001 | 0.005 > 0 °C 0.005 - 0.003% < 0 °C | N/A | 0.001% of span |
| Other input types | | | | |
| Millivolt Input | | 0.00025 mV | Entire Sensor Input Range | 0.001% of span |
| 2-, 3-, 4-wire Ohm Input | | 0.007 Ω | Entire Sensor Input Range | 0.001% of span |

- (1) Change in ambient is in reference to the calibration temperature of the transmitter (20 °C [68 °F]).
- (2) Ambient temperature effect specification valid over minimum temperature span of 28°C (50°F)
- (3) Applies to HART / 4-20 mA devices.

Temperature effects example

When using a Pt 100 (α = 0.00385) sensor input with a 0 to 100 °C span at 30 °C ambient temperature, the following statements would be true:

Digital temp effects

- $0.0015 \frac{^{\circ}\text{C}}{^{\circ}\text{C}} \times (30^{\circ}\text{C} - 20^{\circ}\text{C}) = 0.015^{\circ}\text{C}$

D/A effects (HART / 4–20 mA only)%

- $[0.001\% / ^{\circ}\text{C of span}] \times |(\text{Ambient temp} - \text{Calibrated temp})|$
= D/A Effects
- $[0.001\% / ^{\circ}\text{C} \times 100] \times |(30 - 20)| = 0.01^{\circ}\text{C}$

Worst case error

- Digital + D/A + Digital Temp Effects + D/A Effects
= 0.10 °C + 0.02 °C + 0.015 °C + 0.01 °C = 0.145 °C

Total probable error

$$\sqrt{0.10^2 + 0.02^2 + 0.015^2 + 0.01^2} = 0.10^{\circ}\text{C}$$

HART/4–20 mA specifications

Power supply

External power supply required. Transmitters operate on 12.0 to 42.4 Vdc transmitter terminal voltage (with 250 ohm load, 18.1 Vdc power supply voltage is required). Transmitter power terminals rated to 42.4 Vdc.

Wiring diagram

See [Figure 5 on page 24](#).

Alarms

Custom factory configurations of alarm and saturation levels are available for valid values with option code C1. These values can also be configured in the field using a Field Communicator.

Transient protection (option code T1)

The transient protector helps to prevent damage to the transmitter from transients induced on the loop wiring by lightning, welding, heavy electrical equipment, or switch gears. The transient protection electronics are contained in an add-on assembly that attaches to the standard transmitter terminal block. The external ground lug assembly (code G1) is included with the Transient Protector. The transient protector has been tested per the following standard:

- IEEE C62.41-1991 (IEEE 587)/ Location Categories B3.
6kV/3kA peak (1.2 × 50 μS Wave 8 × 20 μS Combination Wave) 6kV/0.5kA peak (100 kHz Ring Wave)
EFT, 4kVpeak, 2.5kHz, 5*50nS
- Loop resistance added by protector: 22 ohms max.
- Nominal clamping voltages: 90 V (common mode), 77 V (normal mode)

Local display

Optional five-digit LCD display includes 0–100% bar graph. Digits are 0.4 inches (8 mm) high. Display options include engineering units (°F, °C, °R, K, ohms, and millivolts), percent, and milliamperes. The display can also be set to alternate between engineering units/milliamperes, Sensor 1/Sensor 2, Sensor 1/Sensor 2/Differential Temperature, and Sensor 1/Sensor 2/Average Temperature. All display options, including the decimal point, may be reconfigured in the field using a Field Communicator or AMS[®] Device Manager.

Turn-on time

Performance within specifications is achieved less than 6 seconds after power is applied to the transmitter when the damping value is set to 0 seconds.

Power supply effect

Less than ±0.005% of span per volt.

SIS safety transmitter failure values

IEC 61508 Safety Certified SIL 2 and SIL 3 Claim Limit

- Safety accuracy: Span ≥ 100 °C: ± 2% of process variable span
- Span < 100 °C: ± 2 °C
- Safety response time: 5 seconds
- Safety specifications and FMEDA Report available at www.rosemount.com/safety
- Software suitable for SIL3 Applications

Temperature limits

| Description | Operating limit | Storage limit |
|---------------------------------|-------------------------------|--------------------------------|
| Without LCD display | -40 to 185 °F -40 to 85 °C | -60 to 250 °F -50 to 120 °C |
| With LCD display ⁽¹⁾ | -40 to 185 °F -40 to 85 °C | -40 to 185 °F -40 to 85 °C |

(1) LCD display may not be readable and LCD display updates will be slower at temperatures below -4 °F (-20 °C).

Field Communicator connections

Field Communicator connections are permanently fixed to power/signal block.

Failure mode

The Rosemount 3144P features software and hardware failure mode detection. An independent circuit is designed to provide backup alarm output if the microprocessor hardware or software fails.

The alarm level is user-selectable using the failure mode switch. If failure occurs, the position of the hardware switch determines the direction in which the output is driven (HIGH or LOW). The switch feeds into the digital-to-analog (D/A) converter, which drives the proper alarm output even if the microprocessor fails. The values at which the transmitter drives its output in failure mode depends on whether it is configured to standard, or NAMUR-compliant (NAMUR recommendation NE 43) operation. The values for standard and NAMUR-compliant operation are as follows:

Table 4. Operation Parameters

| | Standard ⁽¹⁾ | NAMUR-compliant ⁽¹⁾ |
|---------------|--------------------------|--------------------------------|
| Linear Output | 3.9 ≤ I ≤ 20.5 | 3.8 ≤ I ≤ 20.5 |
| Fail HIGH | 21.75 ≤ I ≤ 23 (default) | 21.5 ≤ I ≤ 23 (default) |
| Fail Low | I ≤ 3.75 | I ≤ 3.6 |

(1) Measured in milliamperes.

Load limitations

Maximum load = 40.8 × (supply voltage - 12.0)⁽¹⁾

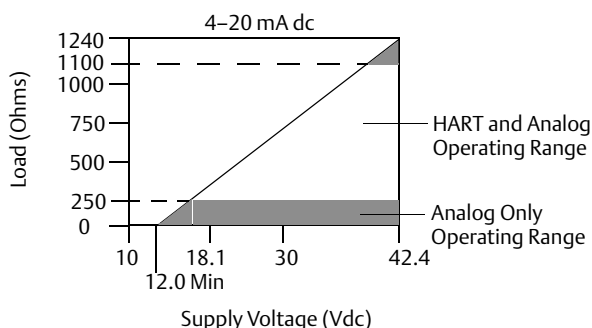

(1) Without transient protection (optional).

Note

HART communication requires a loop resistance between 250 and 1100 ohms. Do not communicate with the transmitter when power is below 12 Vdc at the transmitter terminals.

FOUNDATION fieldbus specifications

Fieldbus Foundation device registration

Device tested and registered to ITK 6.0.1

Power supply

Powered over FOUNDATION fieldbus with standard fieldbus power supplies. Transmitters operate on 9.0 to 32.0 Vdc, 12 mA maximum. Transmitter power terminals are rated to 42.4 Vdc.

Wiring diagram

See [Figure 6 on page 24](#).

Alarms

The AI function block allows the user to configure the alarms to HIGH-HIGH, HIGH, LOW, or LOW-LOW with a variety of priority levels and hysteresis settings.

Transient protection (option code T1)

The transient protector helps to prevent damage to the transmitter from transients induced on the loop wiring by lightning, welding, heavy electrical equipment, or switch gears. The transient protection electronics are contained in an add-on assembly that attaches to the standard transmitter terminal block. The transient terminal block is not polarity insensitive. The transient protector has been tested to the following standard:

- IEEE C62.41-1991 (IEEE 587)/ Location Categories B3.
6kV/3kA peak ($1.2 \times 50 \mu\text{S}$ Wave $8 \times 20 \mu\text{S}$ Combination Wave)
6kV/0.5kA peak (100 kHz Ring Wave)
EFT, 4kVpeak, 2.5kHz, $5 \times 50\text{nS}$
- Loop resistance added by protector: 22 ohms maximum
- Nominal clamping voltages: 90 V (common mode), 77 V (normal mode)

Diagnostics suite for FOUNDATION fieldbus (option code D01)

The 3144P Diagnostics Suite for FOUNDATION fieldbus provides advanced functionality in the form of Statistical Process Monitoring (SPM), a thermocouple Diagnostic, and Sensor Drift Alert. SPM technology calculates the mean and standard deviation of the process variable and makes them available to the user. This may be used to detect abnormal process situations.

The Thermocouple Diagnostic enables the 3144P to measure and monitor the resistance of thermocouple loops in order to detect drift or changing wiring connections.

Sensor Drift Alert allows the user to monitor the difference in measurement between two sensors installed in one process point. A change in this differential value may indicate drifting sensors.

Local display

Displays all DS_65 measurements in the Transducer and Function Blocks including Sensor 1, Sensor 2, differential, and terminal temperatures. The display alternates up to four selected items. The meter can display up to five digits in engineering units ($^{\circ}\text{F}$, $^{\circ}\text{C}$, $^{\circ}\text{R}$, K, Ω , and millivolts). Display settings are configured at the factory according to the transmitter configuration (standard or custom). These settings can be reconfigured in the field using a Field Communicator or DeltaV™. In addition, the LCD display provides the ability to display DS_65 parameters from other devices. In addition to the configuration of the meter, sensor diagnostic data is displayed. If the measurement status is Good, the measured value is shown. If the measurement status is Uncertain, the status indicating uncertain is shown in addition to the measured value. If the measurement status is Bad, the reason for the bad measurement is shown.

Note

When ordering a spare electronics module assembly, the LCD display transducer block will display the default parameter.

Turn-on time

Performance within specifications is achieved less than 20 seconds after power is applied to the transmitter when the damping value is set to 0 seconds.

Status

The device is compliant to NAMUR NE 107, ensuring consistent, reliable and standardized device diagnostic information.

The new standard is designed to improve the way device status and diagnostic information is communicated to operators and maintenance personnel in order to increase productivity and reduce costs.

If self-diagnostics detect a sensor burnout or a transmitter failure, the status of the measurement will be updated accordingly. The status may also send the PID output to a safe value.

FOUNDATION fieldbus parameters

| | |
|--|-----------|
| Schedule Entries | 25 (max.) |
| Links | 30 (max.) |
| Virtual Communications Relationships (VCR) | 20 (max.) |

Backup Link Active Scheduler (LAS)

The transmitter is classified as a device link master, which means it can function as a Link Active Scheduler (LAS) if the current link master device fails or is removed from the segment. The host or other configuration tool is used to download the schedule for the application to the link master device. In the absence of a primary link master, the transmitter will claim the LAS and provide permanent control for the H1 segment.

Function blocks

- All blocks will ship with unique block names, e.g. AI_1400_XXXX.
- All blocks shall be instantiated to avoid invalid defaults.
- All Rosemount 3144P FF have parameter COMPATIBILITY_REV for backward compatibility.
- Parameters will be initialized to common values for easier bench configuration.
- All default block tags are less than or equal to 16 characters in length to avoid inconvenience of apparently identical tags.
- Default block tags include underscores, “_”, instead of whitespaces for easier configuration.

Resource block

- Contains physical transmitter information including available memory, manufacture identification, device type, software tag, and unique identification.
- PlantWeb Alerts enable the full power of the PW digital architecture by diagnosing instrumentation issues, communicating the details, and recommending a solution.

Transducer block

- Contains the actual temperature measurement data, including sensor 1, sensor 2, and terminal temperature
- Includes information about sensor type and configuration, engineering units, linearization, range, damping, and diagnostics
- Device Revision 3 and above includes Hot Backup functionality in the transducer block

LCD display block (when an LCD display is used)

- Configures the local display.

Analog input (AI)

- Processes the measurement and makes it available on the fieldbus segment.
- Allows filtering, engineering unit, and alarm changes.
- All devices ship with the AI blocks scheduled, meaning no configuration is needed if the factory default channels are used

PID block (provides control functionality)

- Performs single loop, cascade, or feedforward control in the field.

| Block | Execution time |
|---------------------------|-----------------|
| Resource | N/A |
| Transducer | N/A |
| LCD display Block | N/A |
| Advanced Diagnostics | N/A |
| Analog Input 1, 2, 3, 4 | 60 milliseconds |
| PID 1 and 2 with Autotune | 90 milliseconds |
| Input Selector | 65 milliseconds |
| Signal Characterizer | 60 milliseconds |
| Arithmetic | 60 milliseconds |
| Output Splitter | 60 milliseconds |

Product Certifications

Rev 1.1

European Directive Information

A copy of the EC Declaration of Conformity can be found at the end of the Quick Start Guide. The most recent revision of the EC Declaration of Conformity can be found at www.rosemount.com.

Ordinary Location Certification

As standard, the transmitter has been examined and tested to determine that the design meets the basic electrical, mechanical, and fire protection requirements by a nationally recognized test laboratory (NRTL) as accredited by the Federal Occupational Safety and Health Administration (OSHA).

North America

E5 FM Explosionproof, Dust-Ignitionproof, and Nonincendive Certificate: 3012752

Standards: FM Class 3600: 1998, FM Class 3611: 2004, FM Class 3615: 1989, FM Class 3810: 2005, NEMA-250: 1991, ANSI/ISA 60079-0: 2009, ANSI/ISA 60079-11: 2009

Markings: XP CL I, DIV 1, GP A, B, C, D; T5(-50 °C ≤ T_a ≤ +85 °C); DIP CL II/III, DIV 1, GP E, F, G; T5(-50 °C ≤ T_a ≤ +75 °C); T6(-50 °C ≤ T_a ≤ +60 °C); when installed per Rosemount drawing 03144-0320; NI CL I, DIV 2, GP A, B, C, D; T5(-60 °C ≤ T_a ≤ +75 °C); T6(-60 °C ≤ T_a ≤ +50 °C); when installed per Rosemount drawing 03144-0321, 03144-5075;

I5 FM Intrinsic Safety and Nonincendive Certificate: 3012752

Standards: FM Class 3600: 1998, FM Class 3610: 2010, FM Class 3611: 2004, FM Class 3810: 2005, NEMA-250: 1991, ANSI/ISA 60079-0: 2009, ANSI/ISA 60079-11: 2009

Markings: IS CL I / II / III, DIV 1, GP A, B, C, D, E, F, G; T4(-60 °C ≤ T_a ≤ +60 °C); IS [Entity] CL I, Zone 0, AEx ia IIC T4(-60 °C ≤ T_a ≤ +60 °C); NI CL I, DIV 2, GP A, B, C, D; T5(-60 °C ≤ T_a ≤ +75 °C); T6(-60 °C ≤ T_a ≤ +50 °C); when installed per Rosemount drawing 03144-0321, 03144-5075;

I6 CSA Intrinsic Safety and Division 2

Certificate: 1242650

Standards: CAN/CSA C22.2 No. 0-M91 (R2001), CAN/CSA-C22.2 No. 94-M91, CSA Std C22.2 No. 142-M1987, CAN/CSA-C22.2 No. 157-92, CSA Std C22.2 No. 213-M1987;

Markings: Intrinsically Safe for Class I Groups A, B, C, D; Class II, Groups E, F, G; Class III; [HART only zone markings]: Intrinsically Safe for Class I Zone 0 Group IIC; T4(-50 °C ≤ T_a ≤ +60 °C); Type 4X; Suitable for Class I, Div. 2, Groups A, B, C, D; [HART only zone markings]: Suitable for Class I Zone 2 Group IIC; T6(-60 °C ≤ T_a ≤ +60 °C); T5(-60 °C ≤ T_a ≤ +85 °C); when installed per Rosemount drawing 03144-5076;

K6 CSA Explosionproof, Intrinsic Safety and Division 2

Certificate: 1242650

Standards: CAN/CSA C22.2 No. 0-M91 (R2001), CSA Std C22.2 No. 30-M1986; CAN/CSA-C22.2 No. 94-M91, CSA Std C22.2 No. 142-M1987, CAN/CSA-C22.2 No. 157-92, CSA Std C22.2 No. 213-M1987;

Markings: Explosionproof for Class I, Groups A, B, C, D; Class II, Groups E, F, G; Class III; [HART only zone markings]: Suitable for Class I Zone 1 Group IIC; Intrinsically Safe for Class I Groups A, B, C, D; Class II, Groups E, F, G; Class III; [HART only zone markings]: Suitable for Class I Zone 0 Group IIC; T4(-50 °C ≤ T_a ≤ +60 °C); Type 4X; Suitable for Class I, Div. 2, Groups A, B, C, D; [HART only zone markings]: Suitable for Class I Zone 2 Group IIC; T6(-60 °C ≤ T_a ≤ +60 °C); T5(-60 °C ≤ T_a ≤ +85 °C); when installed per Rosemount drawing 03144-5076;

Europe

E1 ATEX Flameproof

Certificate: FM12ATEX0065X

Standards: EN 60079-0: 2012, EN 60079-1: 2007, EN 60529:1991 +A1:2000

Markings:  II 2 G Ex d IIC T6...T1 Gb, T6(-50 °C ≤ T_a ≤ +40 °C), T5...T1(-50 °C ≤ T_a ≤ +60 °C);

See [Table 5](#) at the end of the Product Certifications section for Process Temperatures.

Special Conditions for Safe Use (X):

1. See certificate for ambient temperature range.
2. The non-metallic label may store an electrostatic charge and become a source of ignition in Group III environments.
3. Guard the LCD display cover against impact energies greater than 4 joules.
4. Consult the manufacturer if dimensional information on the flameproof joints is necessary.

I1 ATEX Intrinsic Safety

Certificate: BAS01ATEX1431X [HART];
 Baseefa03ATEX0708X [Fieldbus];
 Standards: EN 60079-0: 2012; EN 60079-11:2012;
 Markings: HART: Ⓢ II 1 G Ex ia IIC T5/T6 Ga;
 T6(-60 °C ≤ T_a ≤ +50 °C),
 T5(-60 °C ≤ T_a ≤ +75 °C);
 Fieldbus: Ⓢ II 1 G Ex ia IIC T4 Ga;
 T4(-60 °C ≤ T_a ≤ +60 °C),
 See [Table 6](#) at the end of the Product Certifications section for Entity Parameters

Special Conditions for Safe Use (X):

1. When fitted with the transient terminal options, the equipment is not capable of passing the 500 V insulation test. This must be taken into account during installation.
2. The enclosure may be made from aluminum alloy with a protective polyurethane paint finish; however, care should be taken to protect it from impact or abrasion when located in Zone 0.

N1 ATEX Type n

Certificate: BAS01ATEX3432X [HART];
 Baseefa03ATEX0709X [Fieldbus]
 Standards: EN 60079-0:2012, EN 60079-15:2010
 Markings: HART: Ⓢ II 3 G Ex nA IIC T5/T6 Gc;
 T6(-40 °C ≤ T_a ≤ +50 °C),
 T5(-40 °C ≤ T_a ≤ +75 °C);
 Fieldbus: Ⓢ II 3 G Ex nA IIC T5 Gc;
 T5(-40 °C ≤ T_a ≤ +75 °C);

Special Condition for Safe Use (X):

1. When fitted with the transient terminal options, the equipment is not capable of withstanding the 500 V electrical strength test as defined in clause 6.5.1 of EN 60079-15: 2010. This must be taken into account during installation.

ND ATEX Dust

Certificate: FM12ATEX0065X
 Standards: EN 60079-0: 2012, EN 60079-31: 2009,
 EN 60529:1991 +A1:2000
 Markings: Ⓢ II 2 D Ex tb IIIC T130 °C Db,
 (-40 °C ≤ T_a ≤ +70 °C); IP66
 See [Table 5](#) at the end of the Product Certifications section for Process Temperatures.

Special Conditions for Safe Use (X):

1. See certificate for ambient temperature range
2. The non-metallic label may store an electrostatic charge and become a source of ignition in Group III environments.
3. Guard the LCD display cover against impact energies greater than 4 joules.
4. Consult the manufacturer if dimensional information on the flameproof joints is necessary.

International**E7 IECEx Flameproof**

Certificate: IECEx FMG 12.0022X
 Standards: IEC 60079-0:2011, IEC 60079-1:2007-04,
 IEC 60079-31:2008
 Markings: Ex d IIC T6...T1 Gb, T6(-50 °C ≤ T_a ≤ +40 °C),
 T5...T1(-50 °C ≤ T_a ≤ +60 °C);
 Ex tb IIIC T130 °C Db, (-40 °C ≤ T_a ≤ +70 °C);
 IP66;

See [Table 5](#) at the end of the Product Certifications section for Process Temperatures.

Special Conditions for Safe Use (X):

1. See certificate for ambient temperature range
2. The non-metallic label may store an electrostatic charge and become a source of ignition in Group III environments
3. Guard the LCD display cover against impact energies greater than 4 joules
4. Consult the manufacturer if dimensional information on the flameproof joints is necessary

I7 IECEx Intrinsic Safety

Certificate: IECEx BAS 07.0002X [HART];
 IECEx BAS 07.0004X [Fieldbus]
 Standards: IEC 60079-0: 2011; IEC 60079-11: 2011;
 Markings: HART: Ex ia IIC T5/T6 Ga;
 T6(-60 °C ≤ T_a ≤ +50 °C),
 T5(-60 °C ≤ T_a ≤ +75 °C);
 Fieldbus: Ex ia IIC T4 Ga;
 T4(-60 °C ≤ T_a ≤ +60 °C),

See [Table 6](#) at the end of the Product Certifications section for Entity Parameters.

Special Conditions for Safe Use (X):

1. When fitted with the transient terminal options, the apparatus is not capable of withstanding the 500 V electrical strength test as defined in Clause 6.3.13 of IEC 60079-11: 2011. This must be taken into account during installation.
2. The enclosure may be made from aluminum alloy with a protective polyurethane paint finish; however, care should be taken to protect it from impact or abrasion when located in Zone 0.

- N7** IECEx Type n
 Certificate: IECEx BAS 070003X [HART];
 IECEx BAS 07.0005X [Fieldbus]
 Standards: IEC 60079-0:2011, IEC 60079-15:2010
 Markings: HART: Ex nA IIC T5/T6 Gc;
 T6(-40 °C ≤ T_a ≤ +50 °C),
 T5(-40 °C ≤ T_a ≤ +75 °C);
 Fieldbus: Ex nA IIC T5 Gc;
 T5(-40 °C ≤ T_a ≤ + 75 °C),

Brazil

- E2** INMETRO Flameproof
 Certificate: UL-BR 13.0535X
 Standards: ABNT NBR IEC 60079-0:2008 + corrigendum
 1:2011, ABNT NBR IEC 60079-1:2009 +
 corrigendum 1:2011
 Markings: Ex d IIC T6...T1* Gb; T6...T1*:
 -50 °C ≤ T_a ≤ +40 °C,
 T5...T1* : - 50 °C ≤ T_a ≤ +60 °C)

Special Conditions for Safe Use (X):

1. See product description for ambient temperature limits and process temperature limits.
 2. The non-metallic label may store an electrostatic charge and become a source of ignition in Group III environments.
 3. Guard the LCD cover against impact energies greater than 4 joules.
 4. Consult the manufacturer if dimensional information on the flameproof joints is necessary.
- I2** INMETRO Intrinsic Safety [HART]
 Certificate: UL-BR 15.0088X
 Standards: ABNT NBR IEC 60079-0:2008 + corrigendum
 1:2011, ABNT NBR IEC 60079-11:2009
 Markings: Ex ia IIC T6 Ga (-60 °C ≤ T_a ≤ +50 °C),
 Ex ia IIC T6 Ga (-60 °C ≤ T_a ≤ +75 °C)
 See [Table 6](#) at the end of the Product Certifications section for Entity Parameters.

Special Conditions for Safe Use (X):

1. When fitted with the transient terminal options, the equipment is not capable of withstanding the 500 V electrical strength test as defined in ABNT NBR IEC60079-11. This must be taken into account during installation.
2. The enclosure may be made from aluminum alloy with a protective polyurethane paint finish; however, care should be taken to protect it from impact and abrasion when located in areas that require EPL Ga (Zone 0).
 INMETRO Intrinsic Safety [Fieldbus/FISCO]
 Certificate: UL-BR 15.0030X
 Standards: ABNT NBR IEC 60079-0:2008 + corrigendum
 1:2011, ABNT NBR IEC 60079-11:2009
 Markings: Ex ia IIC T4 Ga (-60 °C ≤ T_a ≤ +60 °C),
 See [Table 6](#) at the end of the Product Certifications section for Entity Parameters.

Special Condition for Safe Use (X):

1. When mounted with the terminal options with transient protection, the equipment is not capable of withstanding the dielectric strength test with 500 V as defined in ISO IEC 60079-11. This feature should be taken into account during installation.

China

- E3** China Flameproof
 Certificate: GYJ11.1650X
 Standards: GB3836.1-2000, GB3836.2-2010
 Markings: Ex d IIC T5/T6 Gb

Special Conditions for Safe Use (X):

1. Symbol “X” is used to denote specific conditions of use: For information on the dimensions of the flameproof joints the manufacturer shall be contacted. This shall be mentioned in the manual.
2. Relation between T code and ambient temperature range is:

| T code | Ambient temperature |
|--------|----------------------------------|
| T6 | -40 °C ≤ T _a ≤ +70 °C |
| T5 | -40 °C ≤ T _a ≤ +80 °C |

3. The earth connection facility in the enclosure should be connected reliably.
4. During installation, there should be no mixture harmful to flameproof housing.
5. During installation in hazardous location. Cable glands, conduits and blanking plugs, certified by state-appointed inspection bodies with Ex d IIC Gb degree, should be used.
6. During installation, use and maintenance in explosive gas atmospheres, observe the warning “Do not open when energized”.
7. End users is not permitted to change any components insides, but to settle the problem in conjunction with manufacturer to avoid damage to the product.
8. When installation, use and maintenance of this product, observe following standards:
 GB3836.13-1997 “Electrical apparatus for explosive gas atmospheres Part 13: Repair and overhaul for apparatus used in explosive gas atmospheres”
 GB3836.15-2000 “Electrical apparatus for explosive gas atmospheres Part 15: Electrical installations in hazardous area (other than mines)”
 GB3836.16-2006 “Electrical apparatus for explosive gas atmospheres Part 16: Inspection and maintenance of electrical installation (other than mines)”
 GB50257-1996 “Code for construction and acceptance of electric device for explosion atmospheres and fire hazard electrical equipment installation engineering”

- I3** China Intrinsic Safety
 Certificate: GYJ11.1536X
 Standards: GB3836.1-2000, GB3836.4-2010
 Markings: Ex ia IIC T4/T5/T6

Special Conditions for Safe Use (X):

- Symbol "X" is used to denote specific conditions of use:
 - The enclosure may contain light metal, attention should be taken to avoid ignition hazard due to impact or friction when used in Zone 0.
 - When fitted with the "Transient Terminal Option", this apparatus is not capable of withstanding the 500 V r.m.s. insulation test required by Clause 6.3.12 of GB3836.4-2010
- Relation between T code and ambient temperature range is:

| Output | T code | Ambient temperature |
|----------|--------|---|
| HART | T6 | $-60^{\circ}\text{C} \leq T_a \leq +50^{\circ}\text{C}$ |
| | T5 | $-60^{\circ}\text{C} \leq T_a \leq +70^{\circ}\text{C}$ |
| Fieldbus | T4 | $-60^{\circ}\text{C} \leq T_a \leq +60^{\circ}\text{C}$ |

- Parameters:

Power/loop terminals (+ and -)

| Output | Maximum input voltage: | Maximum input current: | Maximum input power: | Maximum internal parameters | |
|----------|------------------------|------------------------|----------------------|-----------------------------|-------------------------|
| | U_i (V) | I_i (mA) | P_i (W) | C_i (nF) | L_i (μH) |
| HART | 30 | 300 | 1 | 5 | 0 |
| Fieldbus | 30 | 300 | 1.3 | 2.1 | 0 |

Sensor terminal (1 to 5)

| Output | Maximum input voltage: | Maximum input current: | Maximum input power: | Maximum internal parameters | |
|----------|------------------------|------------------------|----------------------|-----------------------------|-------------------------|
| | U_o (V) | I_o (mA) | P_o (W) | C_i (nF) | L_i (μH) |
| HART | 13.6 | 56 | 0.19 | 78 | 0 |
| Fieldbus | 13.9 | 23 | 0.079 | 7.7 | 0 |

Load connected to sensor terminals (1 to 5)

| Output | Group | Maximum external parameters | |
|----------|-------|-----------------------------|-------------------------|
| | | C_o (μF) | L_o (μH) |
| HART | IIC | 0.74 | 11.7 |
| | IIB | 5.12 | 44 |
| | IIA | 18.52 | 94 |
| Fieldbus | IIC | 0.73 | 30.2 |
| | IIB | 4.8 | 110.9 |
| | IIA | 17.69 | 231.2 |

Temperature transmitters comply to the requirements for FISCO field devices specified in GB3836.19-2010. FISCO parameters are as follows:

| Maximum input voltage: | Maximum input current: | Maximum input power: | Maximum internal parameters | |
|------------------------|------------------------|----------------------|-----------------------------|------------|
| | | | U_i (V) | I_i (mA) |
| 17.5 | 380 | 5.32 | 2.1 | 0 |

- The product should be used with Ex-certified associated apparatus to establish explosion protection system that can be used in explosive gas atmospheres. Wiring and terminals should comply with the instruction manual of the product and associated apparatus.
- The cables between this product and associated apparatus should be shielded cables (the cables must have insulated shield). The shielded has to be grounded reliably in non-hazardous area.
- End users are not permitted to change any components insides, but to settle the problem in conjunction with manufacturer to avoid damage to the product.
- When installation, use and maintenance of this product, observe following standards:
 GB3836.13-1997 "Electrical apparatus for explosive gas atmospheres Part 13: Repair and overhaul for apparatus used in explosive gas atmospheres"
 GB3836.15-2000 "Electrical apparatus for explosive gas atmospheres Part 15: Electrical installations in hazardous area (other than mines)"
 GB3836.6-2006 "Electrical apparatus for explosive gas atmospheres Part 16: Inspection and maintenance of electrical installation (other than mines)"
 GB50257-1996 "Code for construction and acceptance of electric device for explosion atmospheres and fire hazard electrical equipment installation engineering"

EAC - Belarus, Kazakhstan, Russia

- EM** Technical Regulation Customs Union (EAC) Flameproof
 Certificate: RU C-US.GB05.B.00289
 Markings: 1Ex d IIC T6...T1 Gb X

Special Condition for Safe Use (X):

- See certificate for special conditions.

- IM** Technical Regulation Customs Union (EAC) Intrinsic Safety
 Certificate: RU C-US.GB05.B.00289
 Markings: [HART]: 0Ex ia IIC T5, T6 Ga X;
 [Fieldbus/PROFIBUS[®]]: 0Ex ia IIC T4 Ga X

Special Condition for Safe Use (X):

- See certificate for special conditions.

Japan

E4 TIIS Flameproof

Certificate: TC16120, TC16121

Markings: Ex d IIB T6 (-20 °C ≤ T_a ≤ +55 °C)

Certificate: TC16127, TC16128, TC16129, TC16130

Markings: Ex d IIB T4 (-20 °C ≤ T_a ≤ +55 °C)

Combinations

K1 Combination of E1, I1, N1, and ND

K2 Combination of E2 and I2

K5 Combination of E5 and I5

K7 Combination of E7, I7, N7

KA Combination of K1 and K6

KB Combination of K5, I6, and K6

KM Combination of EM and IM

Tables

Table 5. Process Temperatures

| | T6 | T5 | T4 | T3 | T2 | T1 | T130 | |
|-------------------------|--|---------|---------|---------|---------|---------|---------|--------|
| Max ambient | + 40 °C | + 60 °C | + 60 °C | + 60 °C | + 60 °C | + 60 °C | + 70 °C | |
| Sensor extension | Transmitter with LCD display | | | | | | | |
| | 0-in. | 55 °C | 70 °C | 95 °C | 95 °C | 95 °C | 95 °C | 95 °C |
| | 3-in. | 55 °C | 70 °C | 100 °C | 100 °C | 100 °C | 100 °C | 100 °C |
| | 6-in. | 60 °C | 70 °C | 100 °C | 100 °C | 100 °C | 100 °C | 100 °C |
| | 9-in. | 65 °C | 75 °C | 110 °C | 110 °C | 110 °C | 110 °C | 110 °C |
| | Transmitter without LCD display | | | | | | | |
| | 0-in. | 55 °C | 70 °C | 100 °C | 170 °C | 280 °C | 440 °C | 100 °C |
| | 3-in. | 55 °C | 70 °C | 110 °C | 190 °C | 300 °C | 450 °C | 110 °C |
| | 6-in. | 60 °C | 70 °C | 120 °C | 200 °C | 300 °C | 450 °C | 110 °C |
| | 9-in. | 65 °C | 75 °C | 130 °C | 200 °C | 300 °C | 450 °C | 120 °C |

Table 6. Entity Parameters

| | HART | Fieldbus/PROFIBUS | FISCO |
|---------------------------------|------|-------------------|-------|
| Voltage U _i (V) | 30 | 30 | 17.5 |
| Current I _i (mA) | 300 | 300 | 380 |
| Power P _i (W) | 1 | 1.3 | 5.32 |
| Capacitance C _i (nF) | 5 | 2.1 | 2.1 |
| Inductance L _i (mH) | 0 | 0 | 0 |

Dimensional drawings

Figure 1. Rosemount 3144P Temperature Transmitter

Transmitter exploded view

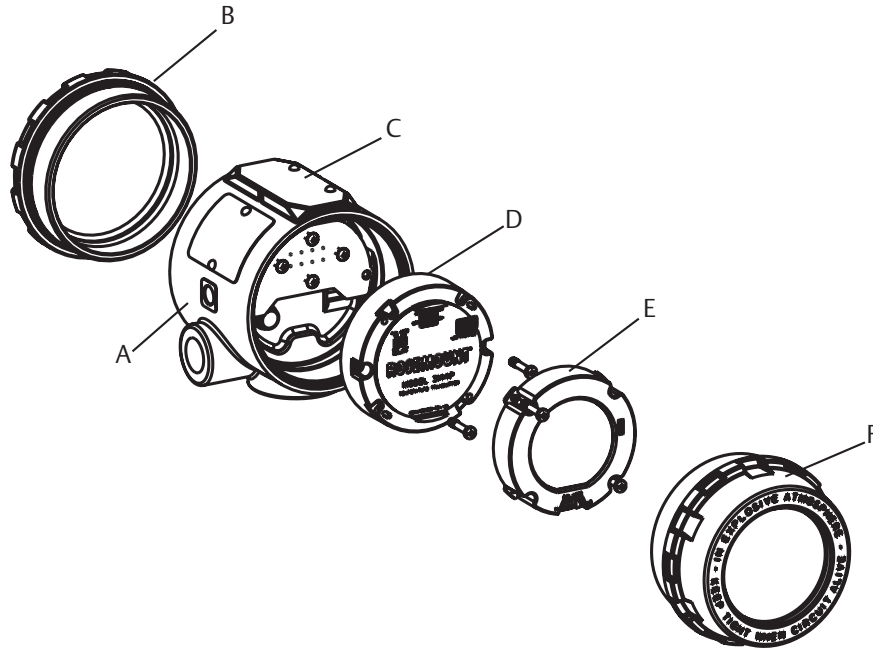

Switch location

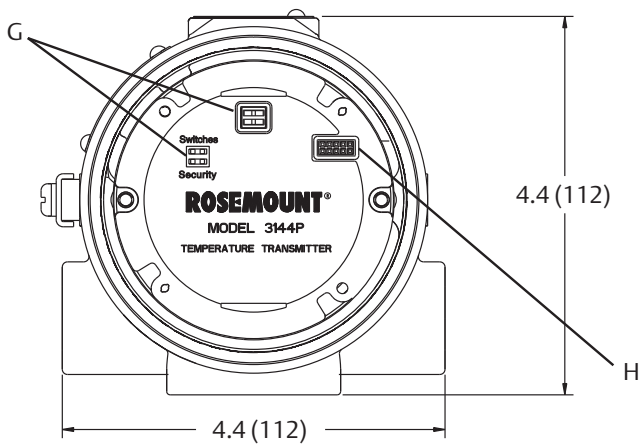

LCD display faceplate

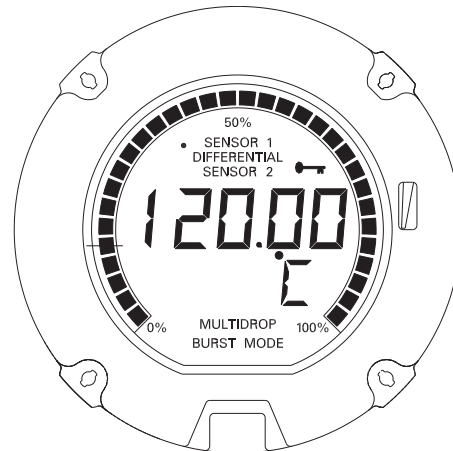

- A. Housing with permanent terminal block
- B. Cover with wiring diagram label
- C. Nameplate
- D. Electronics module

- E. LCD display
- F. Display cover
- G. Switches⁽¹⁾
- H. LCD connector

Dimensions are in inches (millimeters).

(1) Alarm and Write Protect (HART), Simulate and Write Protect (FOUNDATION fieldbus)

Figure 2. Transmitter Dimensional Drawing

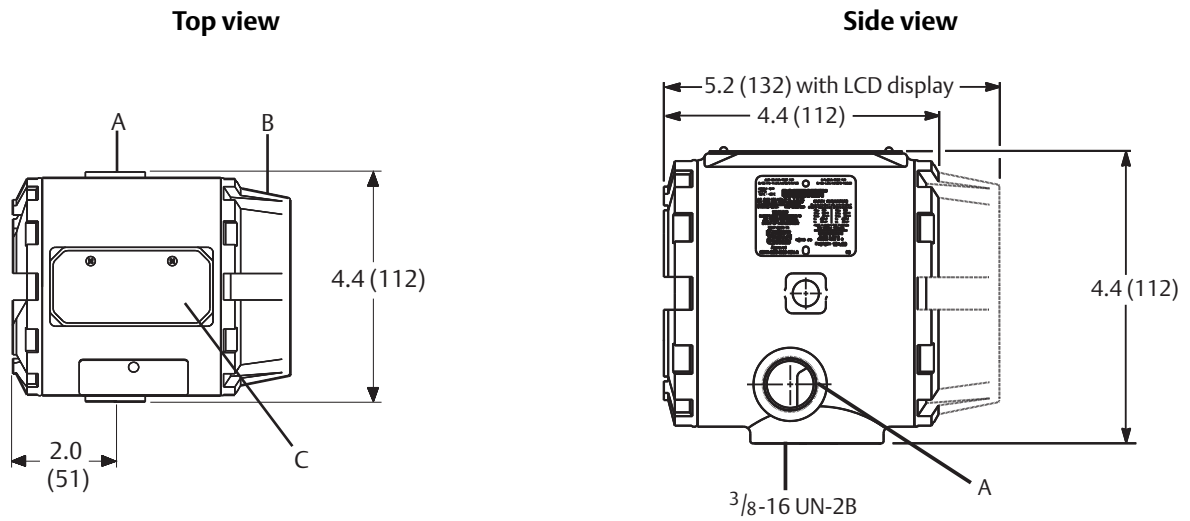

- A. Conduit entry
- B. Display cover
- C. Nameplate

Dimensions are in inches (millimeters).

Figure 3. Transmitter Dimensional Drawing for Conduits with M20 × 1.5, PG 13.5, and JIS G¹/₂ Entries

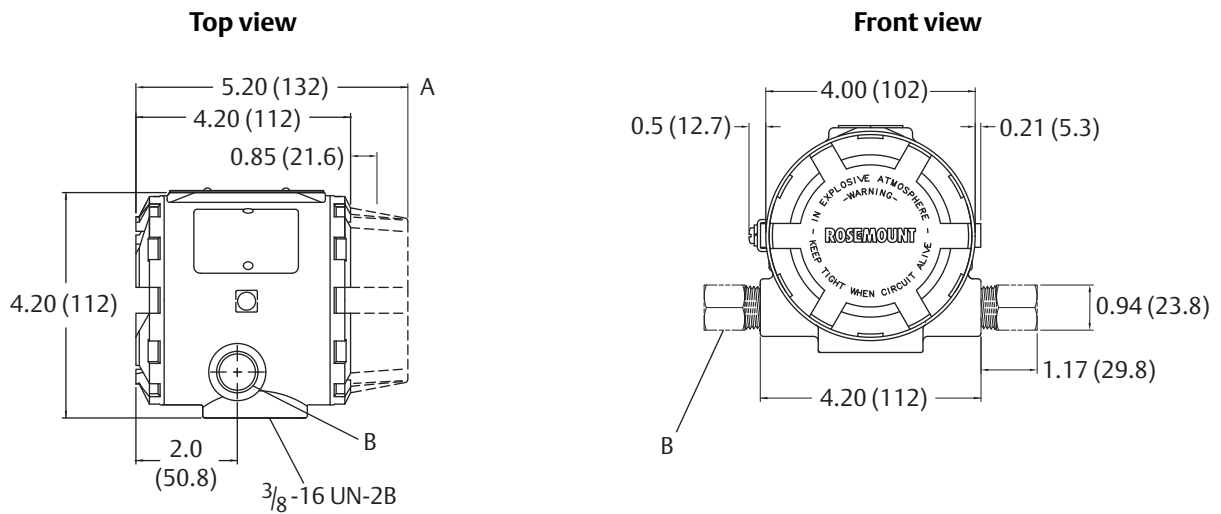

- A. Clearance required to remove cover
- B. Adapters for M20 × 1.5, PG 13.5, and JIS G¹/₂ entries

Dimensions are in inches (millimeters).

Figure 4. Optional Transmitter Mounting Brackets

Option code B4 bracket

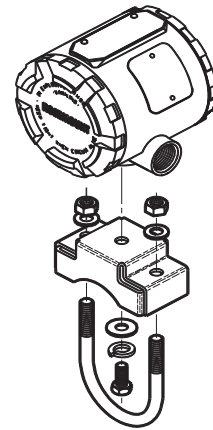
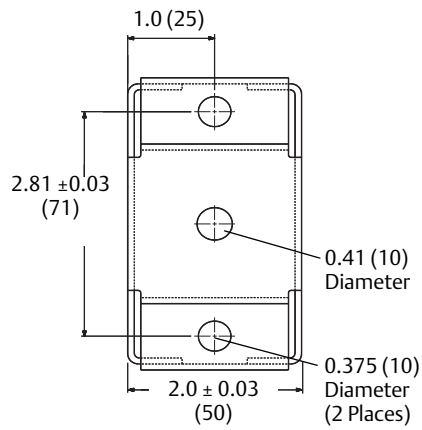
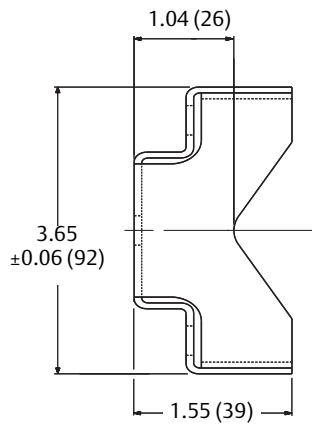

Option code B5 bracket

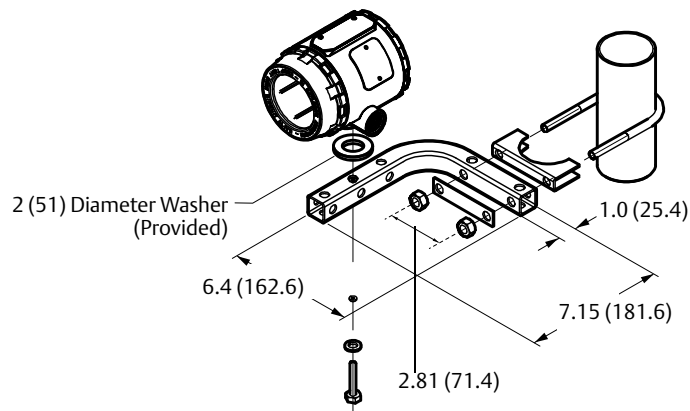

Dimensions are in inches (millimeters).

Figure 5. HART/4–20 mA

3144P single-sensor connections

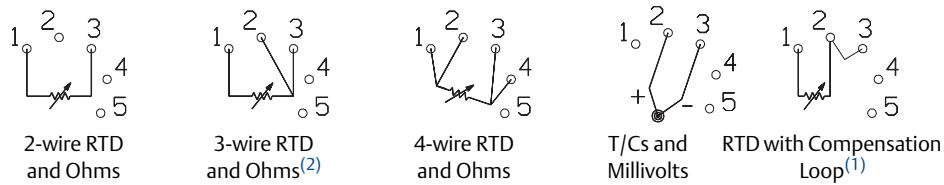

3144P dual-sensor connections

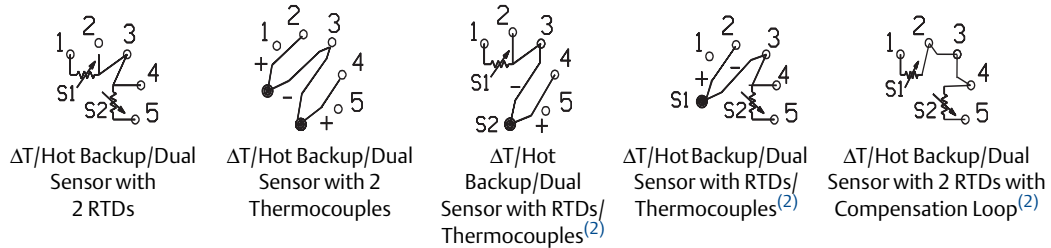

(1) Transmitter must be configured for a 3-wire RTD in order to recognize an RTD with a compensation loop.
 (2) Emerson Process Management provides 4-wire sensors for all single-element RTDs. Use these RTDs in 2-wire or 3-wire configurations by leaving the unneeded leads disconnected and insulated with electrical tape.

Figure 6. FOUNDATION fieldbus

3144P single-sensor connections

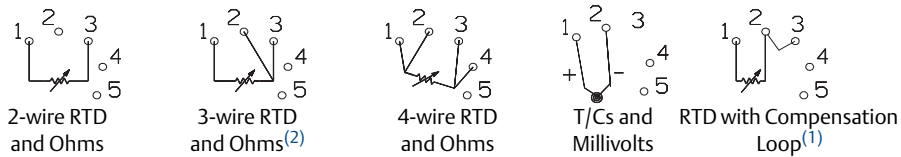

3144P dual-sensor connections

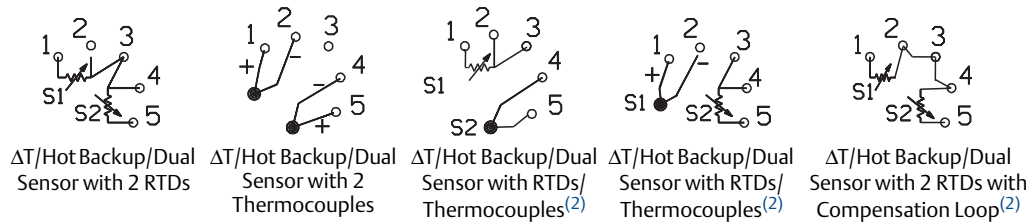

(1) Transmitter must be configured for a 3-wire RTD in order to recognize an RTD with a compensation loop.
 (2) Emerson Process Management provides 4-wire sensors for all single-element RTDs. Use these RTDs in 2-wire or 3-wire configurations by leaving the unneeded leads disconnected and insulated with electrical tape.

Standard configuration

Both standard and custom configuration settings may be changed. Unless specified, the transmitter will be shipped as follows:

| Standard configuration | |
|---|---|
| 4 mA value/Lower Range (HART/4–20 mA) Measurement Point LO (FOUNDATION fieldbus) | 0 °C |
| 20 mA value/Upper Range (HART/4–20 mA) Measurement Point HI (FOUNDATION fieldbus) | 100 °C |
| Damping | 5 seconds |
| Output | Linear with temperature |
| Failure Mode (HART/4–20 mA) | High |
| Line Voltage Filter | 60 Hz |
| Software Tag | See “Software tag” on page 9 |
| Optional Integral Display | Units and mA/Sensor 1 units |
| Single-sensor option | |
| Sensor Type | 4-wire, Pt 100 $\alpha = 0.00385$ RTD |
| Primary Variable (HART/4–20 mA) AI 1400 (FOUNDATION fieldbus) | Sensor 1 |
| Secondary Variable AI 1600 (FOUNDATION fieldbus) | Terminal Temperature |
| Tertiary Variable | Not Used |
| Quaternary Variable | Not Used |
| Dual-sensor option | |
| Sensor Type | Two 3-wire, Pt 100 $\alpha = 0.00385$ RTD |
| Primary Variable (HART/4–20 mA) AI 1400 (FOUNDATION fieldbus) | Sensor 1 |
| Secondary Variable AI 1500 (FOUNDATION fieldbus) | Sensor 2 |
| Tertiary Variable AI 1600 (FOUNDATION fieldbus) | Terminal Temperature |
| Quaternary Variable | Not Used |

Custom configuration

The Rosemount 3144P Transmitter can be ordered with custom configuration. The table below lists the requirements necessary to specify a custom configuration.

| Option code | Requirements/specification |
|------------------------------------|---|
| C1: Factory Data ⁽¹⁾ | Date: day/month/year Descriptor: 16 alphanumeric character Message: 32 alphanumeric character Custom Alarm Levels can be specified for configuration at the factory. |
| C2: Transmitter-Sensor Matching | The 3144P transmitter is designed to accept Callendar-van Dusen constants from a calibrated RTD schedule and generate a custom curve to match any specific sensor curve. Specify a Series 68, 65, or 78 RTD sensor on the order with a special characterization curve (V or X8Q4 option). These constants will be programmed into the 3144P when this option is selected. |
| C4: Five Point Calibration | Will include five-point calibration at 0, 25, 50, 75, and 100% analog and digital output points. Use with option code Q4 to obtain a Calibration Certificate. |
| C7: Special Sensor | Used for non-standard sensor, adding a special sensor or expanding input. Customer must supply the non-standard sensor information. Additional special curve will be added to sensor curve input choices. |

| Option code | Requirements/specification |
|---------------------------------|---|
| A1: NAMUR-Compliant, high alarm | Analog output levels compliant with NAMUR. Alarm is set to fail high. |
| CN: NAMUR-Compliant, low alarm | Analog output levels compliant with NAMUR. Alarm is set to fail low. |
| C8: Low Alarm | Analog output levels compliant with Rosemount standard. Alarm is set to fail low. |
| F5: 50 Hz Line Voltage Filter | Calibrated to 50 Hz line voltage filter. |

(1) CDS required.

To custom configure the 3144P with the dual-sensor option transmitter for one of the applications described below, indicate the appropriate option code in the model number. If a sensor type is not specified, the transmitter will be configured for two 3-wire Pt 100 ($\alpha = 0.00385$) RTDs if any of the following option codes are selected.

| Option Code U1: Hot Backup | |
|----------------------------|---|
| Primary Usage | Primary usage sets the transmitter to automatically use sensor 2 as the primary input if sensor 1 fails. Switching from sensor 1 to sensor 2 is accomplished without any effect on the analog signal. A digital alert will be sent in the event of a failed sensor. |
| Primary Variable | 1st good |
| Secondary Variable | Sensor 1 |
| Tertiary Variable | Sensor 2 |
| Quaternary Variable | Terminal Temperature |

| Option Code U2: Average Temperature with Hot Backup and Sensor Drift Alert – Warning Mode | |
|---|--|
| Primary Usage | Critical applications, such as safety interlocks and control loops. Outputs the average of two measurements and sends a digital alert if temperature difference exceeds the set maximum differential (Sensor Drift Alert – warning mode). If a sensor fails, an alert will be sent digitally and the primary variable will be reported as the remaining good sensor value. |
| Primary Variable | Sensor Average |
| Secondary Variable | Sensor 1 |
| Tertiary Variable | Sensor 2 |
| Quaternary Variable | Terminal Temperature |

| Option Code U3: Average Temperature with Hot Backup and Sensor Drift Alert – Alarm Mode | |
|---|--|
| Primary Usage | Critical applications, such as safety interlocks and control loops. Outputs the average of two measurements and sets the analog output into alarm if temperature difference exceeds the set maximum differential (Sensor Drift Alert – alarm mode). If a sensor fails, an alert will be sent digitally and the primary variable will be reported as the remaining good sensor value. |
| Primary Variable | Sensor Average |
| Secondary Variable | Sensor 1 |
| Tertiary Variable | Sensor 2 |
| Quaternary Variable | Terminal Temperature |

| Option Code U4: Two Independent Sensors | |
|--|--|
| Primary Usage | Used in non-critical applications where the digital output is used to measure two separate process temperatures. |
| Primary Variable | Sensor 1 |
| Secondary Variable | Sensor 2 |
| Tertiary Variable | Terminal Temperature |
| Quaternary Variable | Not Used |

| Option Code U5: Differential Temperature | |
|---|--|
| Primary Usage | The differential temperature of two process temperatures is configured as the primary variable. If the temperature difference exceeds the maximum differential, the analog output will go into alarm. Primary Variable will be reported as a bad sensor value. |
| Primary Variable | Differential Temperature |
| Secondary Variable | Sensor 1 |
| Tertiary Variable | Sensor 2 |
| Quaternary Variable | Terminal Temperature |

| Option Code U6: Average Temperature | |
|--|--|
| Primary Usage | When average measurement of two different process temperatures is required. If a sensor fails, the analog output will go into alarm and the primary variable will report the measurement of the remaining good sensor. |
| Primary Variable | Sensor Average |
| Secondary Variable | Sensor 1 |
| Tertiary Variable | Sensor 2 |
| Quaternary Variable | Terminal Temperature |



ZPA Nová Paka, a.s.

Pražská 470

509 39 Nová Paka

Czech republic

tel.: + 420 493 761 234

fax: + 420 493 721 194

e-mail: obchod@zpanp.cz

www.zpanp.cz