



# Resistance temperature sensor with thermowell ČSN without converter, with converter or Ex ia design type series 240 type 242

## PRODUCT MANUAL

FOR DESIGNS WITH CONVERTER A MANUAL IS ENCLOSED TO THE RELEVANT CONVERTER  
FOR DESIGN WITH CONVERTER AND DISPLAY A MANUAL IS ENCLOSED TO THE RELEVANT CONVERTER AND DISPLAY

### APPLICATION

- For exact remote measurement of temperature of steady and running liquids (gases and fluids), for which the properties of the thermowell of the sensor selected by the customer are suitable; measurement may be realized up to temperature determined by thermowell resistance (max. 600°C) and nominal pressure PN 160
- For explosive environment in premises Zone 2, Zone 1 and Zone 0 pursuant to EN 60079-10 when using the converter Ex ia or in case of connection to Ex ia circuit
- In a set with control or diagnostic systems for process monitoring
- In design with converter for transfer of resistance sensor signal to unified output signal 4 to 20 mA or digital signal (converter with HART protocol)
- In design with display to display the value of the measured value immediately
- For the environment, where mechanical resistance is required pursuant to EN 60068-2-6 (class AH2) and seismic capability of the electrical equipment of the safety system of the nuclear power stations pursuant to IEC 980 (MVZ level SL-2)
- special design for cryogenic environment with medium temperature up to -196 °C

The sensors with converter and in Ex ia design are rated products pursuant to the Directive 2014/34/EU, 2014/30/EU of the European Parliament and the Council and EU Declaration of Conformity **EC-232000** is issued for them.

For use temperature sensors as separate assemblies of the heat meter on placing on the market.

The sensors are rated products pursuant to the Directive 2014/32 EU of the European Parliament and the Council and EU Declaration of Conformity **EU-MID-232000-EN** is issued for them.

**Using sensors within the meaning of Directive 2014/32 EU of the European Parliament and the Council. (MID) as part of the customer's measurement kits, for which the conformity of the assemblies as a whole must be assessed when placed on the market with all the features required by this directive:**

- sensor without transmitter in 1xPt100 /.. / 4 connection can be used by the customer on the basis of an evaluation certificate in its measuring sets in the sense of Directive 2014/32 EU of the European Parliament and the Council

### DESCRIPTION

The sensor consists of a replaceable measuring insert with flange and ceramic terminal board or installed two-wire converter (insulated or non-insulated, even in design Ex i) and protective armature consisting of a head and a thermowell with an adapter and connecting screw union. The head is provided with a lid and a cable outlet for the connecting wiring. The terminal board (of the converter) of the sensor is accessible after tilting away the lid of the head, which is connected with one screw. The sensor with converter in the Ex ia design is provided with an external clamp and an internal clamp on the head for the connection of the grounding wire or wire for mutual interconnection.

The converter is installed either directly on the flange of the measuring insert or in the lid of the head.

The sensor with converter is supplied from an external source. The installed converter is pre-set to the required range at the sensor manufacturer.

To measure temperature, a defined change of sensor resistance in dependence on the change of temperature of the measured environment is used.

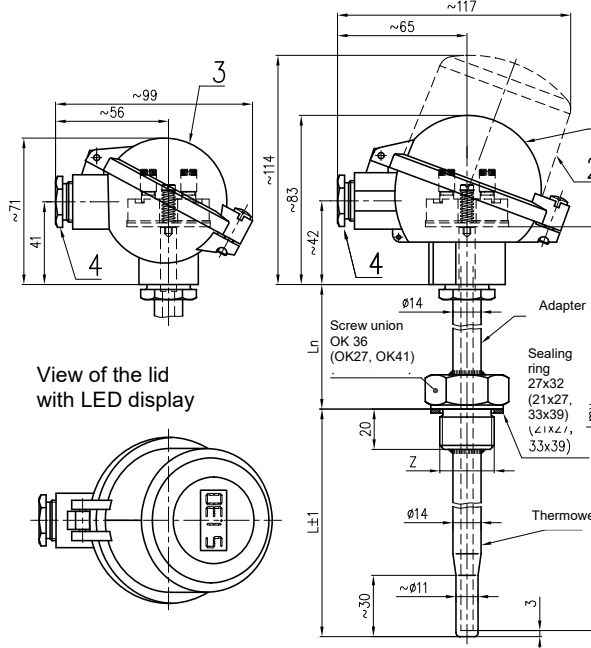

- 1 - Ball head (Al alloy)  
(for the converter Ex i with external and internal clamps)  
or plastic ball head  
(it cannot be used for the converter Ex i)
  - 2 - Ball head with increased lid (alloy Al)  
without display for the converter in the lid or with display  
(for the converter Ex i with external and internal clamps)
  - 3 - Small ball head (Al alloy)  
(only for the terminal board or the converter INPAL 420)
  - 4 - Cable outlet M20x1.5
- L Nominal length  
L<sub>n</sub> Length of adapter  
L<sub>mv</sub> Length of measuring insert  
Z Connecting thread of adapter of the sensor
- |                        |      |
|------------------------|------|
| G½, M20x1.5            | OK27 |
| G3/4, M27x2, 3/4-14NPT | OK36 |
| G1                     | OK41 |

### TECHNICAL DATA

The sensor dimensions are based on the original ČSN 25 8301. The sensor is designed pursuant to EN 61140 as an electric equipment of protection class III for the application in networks with category of overvoltage in installation II and pollution grade 2 pursuant to EN 61010-1; the follow-up (evaluation) device shall comply with Article 6.3 of the said standard.

#### Measuring range:

- The sensor with standard adapter
- L<sub>n</sub> = 150 mm    -70 to 600 °C \*) \*\*)   
 -196 to 100 °C \*\*) \*\*\*)
- The sensor with shortened adapter
- L<sub>n</sub> min = 80 mm    -70 to 250 °C \*) \*\*)   
 -196 to 100 °C \*\*) \*\*\*)

\*) The upper limit of the range of measurement is limited by resistance of the material of the applied thermowell.

\*\*) Class A is only guaranteed in the range from -70 to 300 °C

\*\*\*) Special design for cryogenic environments

Measuring range of the sensor with converter is established by the range of the selected converter

**Electric strength** pursuant to EN 61010-1, Article 6.8.3:  
500 V eff (only measuring insert without converter or design with insulated converter)

**Electric insulation resistance** pursuant to IEC 751,  
min. 100 MΩ, at 15 to 35°C, max. 80 % rel. humidity

**Intrinsically safe** pursuant to EN IEC 60079-0 and EN 60079-11:

- ⊕ II 1 G Ex ia IIC T5/T6 Ga  
(Meaning of designation - see figure 5)
- P<sub>i</sub> = 192 mW T6 (-60°C ≤ Ta ≤ 60°C)
- P<sub>i</sub> = 290 mW T6 (-60°C ≤ Ta ≤ 55°C)
- T5 (-60°C ≤ Ta ≤ 65°C)

**Intrinsically safe circuit parameters:**

only for Pt 100, with measuring insert Ø6

- Input
- U<sub>i</sub> = 60 V
- I<sub>i</sub> = 100 mA
- P<sub>i</sub> = 192 mW / 290 mW
- C<sub>i</sub> = 780 pF/m
- L<sub>i</sub> = 0,6 µH/m



**WARNING**

The device must be installed in a housing that meets the degree of protection against intrusion of at least IP 20. The casing of the measuring insert is not separated from the inner intrinsically safe circuit according to the standard EN 60079-11. This information must be taken into account during installation.



**Intrinsically safe version with converter:**

according to built-in converter

**Power supply of converter:**

DC 24 V from source SELV, e.g. INAP 16 and INAP 901

**Other data of converter:** refer to the enclosed manual

**Ingress protection** pursuant to EN 60529: IP65

**Nominal pressure of thermowell** pursuant to ČSN 13 0010: PN 160

**Operation position:**

discretionary; the outlet shall not be situated upwards

**Type of operation:** continuous

**Sensor weight:**

with ball head (Al alloy), adapter 150 mm and nominal length 250 mm approx. 0.68 kg

**Applied materials:**

Thermowell	steel 1.4541
	steel 1.4571
Stem tube of measuring insert	steel 1.4541
Adapter	steel 1.4541
HEAD	aluminium alloy painted with polyester paint
	plastic PPO (phenyl polyoxide)
Sealing of lid of the head	oil resistant rubber
Internal wiring	Cu
Head terminals of the terminal board	brass with Ni surface
Connecting elements of the sensor	stainless steel

**OPERATION CONDITIONS**

The environment is defined by the group of parameters and their severity grades IE 36 pursuant to EN 60721-3-3 and the following operation conditions.

**Ambient temperature for head and outlet of the sensor:**

- For design without converter -50 °C to 120 °C
- For design with converter pursuant to the type of the converter (refer to the enclosed converter manual)
- For design with converter and display -20 °C to 70 °C

**Intrinsically safe measuring inserts can be used in intrinsically safe circuits of group II electrical equipment.**

**Relative ambient humidity:**

- 10 to 100 % with condensation, with upper limit of water content 29 g H<sub>2</sub>O/kg of dry air
- For design with converter pursuant to type of converter (refer to enclosed converter manual)
- For design with converter and display pursuant to type of converter and display (refer to enclosed converter manual)

**Atmospheric pressure:** 70 to 106 kPa

**Maximum speed of flow of liquids:**

Maximum speed of flow [m/s]	Nominal length [mm]				
	100	160	250	400	630
Water steam and air	50	25	8	2.5	1
Water	5	3	3	1.5	0.2

**Vibrations:**

Nominal length [mm]	100	160	250	400	630
Frequency range [Hz]	10 to 500				
Drift amplitude [mm]	0.2	0.2	0.15	0.15	0.15
Acceleration amplitude [ms <sup>-2</sup> ]	29.4	29.4	19.6	19.6	19.6

**Resistance of material of the head PPO (phenyl polyoxide):**

Kerosene	partially resistant
Diesel oil	resistant
Benzene	partially resistant
Animal and vegetable oil	resistant
Weak hydrohides	
Strong hydroxides	
Weak acids	
Strong acids	
Sea water	
Trichloroethylene	partially resistant

**Resistance of lid sealing material (oil resistant rubber):**

Spirit	resistant
Ether	
Benzole	
Petrol	
Ester	
Animal and vegetable oil	
Mineral oil	
Diesel oil	
Weak alkali hydrohides	
Strong alkali hydroxides	
Weak acids	resistant
Strong acids	not resistant
Sea water	resistant
Trichloroethylene	partially resistant
Hot water	

**METROLOGICAL DATA**

**Sensing probe:** measuring resistor Pt 100 in connection pursuant to scheme and table of designs, α = 0.00385 [K<sup>-1</sup>], tolerance class A or B pursuant to IEC 751

**Internal wiring resistance** at 20 °C: 0.1 Ω/m

The calculated resistance value of internal wiring of the design without converter is specified on the label of the measuring insert.

**Maximum current load of measuring resistor:** 3 mA

**Recommended measuring current:** 1 mA

**Output signal of the converter** (linear with measured temperature): 4 to 20 mA (+ digital for HART protocol)

**Calibration depth of immersion of the measuring insert of the sensor**

for temperature points within range -70 to 250°C: 200 mm (min. 160 mm)

for temperature points above 250°C: 300 mm (min. 260 mm)

The distance of flange of the measuring insert from the level of medium in the calibration bath shall be at least 40 mm at temperatures to 250°C and min. 70 mm at temperatures above 250°C.

**Temperature response time** pursuant to IEC 751 in whirling

water (characteristic value): τ<sub>0.5</sub> 29 s  
τ<sub>0.9</sub> 95 s

**DESIGNATION :**

**Data on label of head**

- Trademark of the manufacturer
- Made in Czech Republic
- Type of resistance sensor, nominal value R<sub>0</sub> / tolerance class / configuration of wires of internal wiring \*)
- Measuring range or set-up converter range
- Product ordering number
- Ingress Protection
- Time code (Serial number for calibrated design, design with tolerance class A, design with converter, EX ia design)
- Output signal 4 to 20 mA (design with converter)
- Ambient temperature
- Mark of non-explosiveness:

⊕ II G Ex ia IIC T5/T6 Ga (Ex ia design)

and number of the EU-Type Examination Certificate

- Mark CE 1026

\*) Configuration of wires of internal wiring is not specified for the converter

#### Data on label of measuring insert

- Trade mark
- Sensor type, nominal value  $R_0$  / tolerance class / configuration of wires of internal wiring \*)
- Time code (Serial number for calibrated design, design with tolerance class A, design with converter, EX ia design)
- Resistance value of internal wiring (for design without converter)

\*) Configuration of wires of internal wiring is not specified for the converter

#### Data on label of converter

- Trademark
- Type of sensor
- Pre-set temperature range
- Designation of non-explosiveness and EU-Type Examination Certificate number (for design with converter Ex ia)
- CE mark with identification number of the notified person (for design with converter)

#### Data on display

- Trademark
- Designation of non-explosiveness and EU-Type Examination Certificate number (for design with converter Ex ia)
- CE mark with identification number of the notified person (for design with converter)

#### DELIVERY

Unless agreed otherwise with the customer, each delivery includes

- Delivery note
- Sensor pursuant to the purchase order
- Sealing ring
  - o 21x27 TPD 62-014-91 for thread  $G\frac{1}{2}$  and M20x1.5
  - o Cu 27 x 32 x1.5 (ČSN 02 9310.2) for thread M27 x 2 and  $G\frac{3}{4}$
  - o Cu 33 x 39 x 2 (ČSN 02 9310.2) for thread G1 (for thread 3/4-14NPT the sealing ring is not delivered)
- Suitable nipples ordered separately pursuant to the catalogue of accessories, type 991
- Optional accessories to the sensor with programmable converter
  - o Configuration (parameterization) programme pursuant to the required converter
  - o Communication modem (for serial port RS 232C) pursuant to the required converter
- Accompanying technical documentation in Czech
  - o Product manual
  - o Product quality and completeness certificate, which also serves as the warranty certificate
  - o EU Declaration of Conformity
    - for Ex ia design
    - for design with proof of metrological compliance (/M5)
  - o Calibration sheet (for uncertified calibrated design)

If it is established in the purchase contract or agreed otherwise, the following documentation can be also delivered with the product

- Copy of the Inspection Certificate 3.1 for material of stem tube and thermowell with the heat number
- Declaration of Conformity with purchase order 2.1 acc. to EN 10204
- Copy of EU-Type Examination Certificate pursuant to the Directive No 2014/34/EU (ATEX). for Ex ia design
- Copy of EU-Type Examination Certificate
- Copy of Evaluation certificate for design /M1, /M2, /M3 and /M4
- Test report about the seismic and the vibration qualification

#### CERTIFICATION

- Non-explosiveness Ex ia, EU-Type Examination Certificate pursuant to the Directive 2014/34/EU FTZÚ 21 ATEX 0007X
- Non-explosiveness Ex i, EU-Type Examination Certificate pursuant to the 2014/34/EU, (pursuant to the type of the converter and display)
- Declaration of metrological conformity (MID) in accordance with Module B of Directive No. 2014/32/EU, EU Type Examination Certificate No. TCM 321/12-4906
- Evaluation certificate. No. ZR 114/10-0068

#### RELIABILITY

Indicators of reliability in operation conditions and ambient conditions specified herein

- Medium time of operation between failures 96 000 hours (inf. value)

Expected service life 10 years

#### CALIBRATION

It is realized pursuant to TPM 3342-94 and in compliance with EN 60751, usually in three temperature points spread evenly within the operation range of the sensor or in the points according to the requirement of the customer. Calibration sheets with measured data are issued for calibrated sensors.

#### ASSESSMENT OF CONFORMITY PURSUANT TO THE DIRECTIVE 2014/32 EU

Couple sensors are verified pursuant to EN 1434-5.

The sensors are rated products pursuant to the Directive 2014/32 EU of the European Parliament and the Council and EU Declaration of Conformity is issued for them.

The manufacturer performs subsequent verification under EN 1434-5. Subsequent verification is ordered in the department AMS ZPA N. Paka a.s. (ams@zpanp.cz).

For subsequent verification, send the whole couple tied together.

#### METHOD OF PLACING THE MARK OF ASSEMBLY AND SERVICE ORGANIZATION AND REINSURANCE MARKS

Verified sensors have a self-adhesive label with reinsurance mark. The label is stuck on the terminal board and the sensor head.

After installation on place of use the sensors will be reassured with mounting seal eventually with label, preventing unauthorized manipulation.

After subsequent verification, the sensors will be provided with a self-adhesive label with an official mark. The label will be stuck on the terminal board and the sensor head instead of the original reinsurance mark.

#### PLACING THE MARK OF ASSEMBLY AND SERVICE ORGANIZATION AND REINSURANCE MARKS

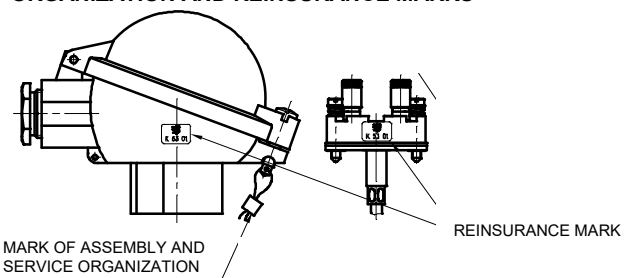

#### PACKING

Both sensors and accessories are delivered in a packing ensuring resistance to the impact of thermal effects and mechanical effects pursuant to controlled packing regulations.

#### STORAGE

The sensors may be stored on conditions corresponding to the set of combinations of classes IE 12 pursuant to EN IEC 60721-3-1, but with ambient temperature from -20 to 70 °C (i.e. in places where temperature and humidity are not regulated, with a threat of occurrence of condensation, dripping water and formation of ice, without a special threat of an attack with biological agents, with vibrations of small significance and not situated close to sources of dust and sand).

## TRANSPORT

The sensors may be transported on conditions corresponding to the set of combinations of classes IE 21 pursuant to EN IEC 60721-3-2 (i.e. by airplanes and trucks, in premises that are ventilated and protected against atmospheric effects).

## ORDERING TEMPERATURE SENSORS

The purchase order shall specify

- Name
- Product ordering number
- Ex ia design is ordered using codes J4X, D2X or D3X according to table 1
- Measuring range
- If calibration is required and in what temperature points
- If the delivery of nipple pursuant to the type 991 is required for the sensor as accessories
- If optional accessories to the sensor with programmable converter are required
- Other (special) requirements
- Number of pieces

Behind the ordering number specified pursuant to the table 1, the customer shall identify the required range of measured temperature (i.e. lower and upper temperature limits in °C) and, as the case may be, other non-standard required parameters for converter configuration (e.g. indication of sensor tripping, dampening, required designation - tagging etc.).

## PURCHASE ORDER EXAMPLE

### Standard design:

Resistance temperature sensor with thermowell ČSN  
Without converter  
242 412 331 1B/J4  
Range -70 to 600°C  
6 pcs

### Special request:

Resistance temperature sensor with thermowell ČSN  
With converter  
242 912 231 1B/18  
Nominal length L 380 mm, range 0 to 100°C  
6 pcs

## ORDERING ACCESSORIES

The purchase order shall specify:

- Name
- Ordering number
- Number of pieces

## EXAMPLE OF PURCHASE ORDER

### Standard design:

Nipple  
991 NVP4 M27 72  
6 pcs

### Special request:

Nipple  
991 NP4 M27 99  
material 1.5415  
6 pcs

TABLE 1 - DESIGN OF TEMPERATURE SENSORS WITH THERMOWELL ČSN TYPE 242

SPECIFICATIONS						ORDERING NUMBER																			
						242	x	x	x	x	x	1	x	x	/xxxxxx	/xxx									
Nominal length L [mm]	100	Length of adapter L <sub>n</sub> [mm]	150	Length of measuring insert L <sub>mv</sub> [mm]	280	1																			
	160				340	2																			
	250				430	3																			
	400				580	4	1																		
	630				810	5																			
	Other (min. 75 *)								9																
Nominal length L [mm]	100	Length of adapter L <sub>n</sub> [mm]	80	Length of measuring insert L <sub>mv</sub> [mm]	210	1																			
	160				270	2																			
	250				360	3																			
	400				510	4	2																		
	630				740	5																			
	Other (min. 75 *)								9																
Length of adapter	150 mm																								
	80 mm																								
	Other *)**)	max. -70 to 250°C																							
Thermowell material	1.4571 ***)	max. -70 to 400°C																							
	1.4541 ***)	max. -70 to 600°C																							
	Other *)																								
Connecting thread	G1/2																								
	G1																								
	M27x2																								
	G3/4																								
	3/4-14 NPT																								
	M20x1.5																								
Sensor head	Ball (Al alloy) (with converter Ex i with external and internal clamps)																								
	Plastic ball (it cannot be used with converter Ex i)																								
	Ball head with increased lid (Al alloy) without display with converter in the lid or with display (with converter Ex i with external and internal clamps)																								
	Small ball (Al alloy) (only for the terminal board and the converters INPAL 420, TH 100, MINIPAQ-HLP)																								
	other *)																								
Stem tube of measuring insert for sensor with thermowell																									
Measuring resistor (sensing probe)	Pt100																								
	Pt500 *)																								
Tolerance class	A	guaranteed only within range to 300°C																							
	B																								
Connection of the terminal board	Single - four-wire (1xPt100/ /4)																								
	Double- two-wire (2xPt100/B/2)																								
	Double- three-wire (2xPt100/ /3)																								
	Single – four-wire	only for Pt 100, with measuring insert ø 6, length of measuring																							
	Double – two-wire	insert L <sub>mv</sub> 100 – 3025 [mm]																							
	Double – three-wire																								
Single - with auxiliary loop (1xPt // 4C)																									

TABLE 1 - DESIGN OF TEMPERATURE SENSORS WITH THERMOWELL ČSN TYPE 242 (continuation)

SPECIFICATIONS					ORDERING NUMBER																
					242	x	x	x	x	x	1	x	x	/xxxxxx	/xxx						
Converter (connection for converter: single, double, three or four-wire, pursuant to the converter)	Converter type	Galvanic separation	Ex ia	NFC	Range [°C]																
	Analogue	INPAL 420				-50 to 50												/07			
						-30 to 70												/55			
						0 to 50													/15		
						0 to 100													/18		
						0 to 150													/19		
						0 to 200													/20		
						0 to 250													/21		
	Programmable	TH 100 TH 100-ex TH 200 TH 200-ex IPAQ-H IPAQ-HX MINIPAQ-HLP APAQ C130 IPAQ C202 IPAQ C202X IPAQ C330 IPAQ C330X				0 to 400	1											/23			
						Programmable range													/TH100		
																			/TH100X		
																				/TH200	
																				/TH200X	
																					/IPAQH
																					/IPAQHx
																					/MINIPAQ
																					/C130
																					/C202
																					/C202
																					/C330
																					/C330X
	HART protocol	IPAQ C520 IPAQ C520S IPAQ C520X IPAQ C520XS IPAQ C530 IPAQ C530X TH 300 TH 300-ex MESO-H MESO-HX 248 HA NA 248 HA I1 644 HA NA 644 HA I1					Programmable range													/C520	
																			/C520S		
																				/C520X	
																				/C520XS	
																				/C530	
																					/C530X
																					/TH300
																					/TH300X
																					/MESOH
																					/MESOHX
	Other *)					Programmable range													/C530X		
																			/248HANA		
																				/248HA1X	
																				/644HANA	
	Without converter (for installation of the converter by the customer)					Programmable range													/644HA1X		
																			/99		
	LED display to loop 4-20mA	LED display LPI-01 (only with converter, except of converter 644 HANA)				Programmable range													/00		
		LED display Ex ia *) (only with converter Ex ia , except of converter 644 HA11X)																	/LD		
Special design for negative temperatures -196°C *)																	/LDX				
																	/CT				

**Standard design**

- \*) Only as a special request after an agreement with the manufacturer
- \*\*) In case of adapter length below 150 mm (minimum 80 mm), the temperature range is decreased to -70 to 250 °C
- \*\*\*) Thermowells of these materials are suitable for contact with food
- \*\*\*\*) Functional safety SIL2

**TABLE 2 – ADDITIONAL REQUIREMENT FOR DESIGN OF TEMPERATURE SENSORS WITH THERMOWELL ČSN TYPE 242**

SPECIFICATIONS				CODE	
PROOF OF METROLOGICAL COMPLIANCE	DESIGN OF TEMPERATURE SENSORS	MEASURING RANGE [°C]		USE	
Proof of metrological compliance pursuant to Directive No. 2014/32/EU (MID), Annex MI-004 *)	couple sensors without converter in connection 1xPt100/..1/4 min. length of measuring insert Ø 6 mm = 210 mm min. immersion = 160 mm	0 to 180		application for residential and business premises and for the light industry	/M5
CALIBRATION (for sensors as described below)	DESIGN OF TEMPERATURE SENSORS	MEASURING RANGE [°C]		USE	
Calibration by TPM 3342-94, in three calibration points evenly distributed in the sensor measuring range for use as part of the customer's measurement assemblies pursuant to Directive No. 2014/32/EU (MID), Annex MI-002 and MI-005 *)	sensors without converter in connection 1xPt100/..1/4 min. length of measuring insert for temperature to 250°C Ø 6 mm = 210 mm for temperature over 250°C Ø 6 mm = 275 mm	-50 to 50		application for residential and business premises and for the light industry	/M1
		-50 to 100			/M2
		0 to 200			/M3
		0 to 250	for sensors with extension lengths shorter than 140 mm (min. 80 mm)		/M4
		0 to 300	for sensor with measuring resistance in tolerance class A		
0 to 400	for sensors with extension lengths 140 mm and longer, with measuring resistance in tolerance class B				
CALIBRATION	NUMBER OF CALIBRATION POINTS	CALIBRATION RANGE			
Calibration by TPM 3342-94, define calibration points	3	0 to 420 °C		/Q1	
	3	0 to 600 °C		/Q2	
	3	-196 to 100 °C		/Q3	
	3	-50 to 600 °C		/Q22	
	Other	-50 to 600 °C		/Q9	
REQUIREMENT FOR OTHER DOCUMENTATION			USE		
Copy of EU-Type Examination Certificate (pursuant to Directive No. 2014/32/EU)			M5		
Copy of Evaluation certificate No. ZR 141/10-0068			M1, M2, M3, and M4		
EU Declaration of Conformity			for design with converter		
Copy of EU-Type Examination Certificate acc to the 2014/34/EU (ATEX)			for Ex ia design		
Copy of the Inspection Certificate 3.1 acc to EN 10204 for material of tube with the heat number					
Declaration of Conformity with purchase order 2.1 pursuant to EN 10204					

Specify the code behind ordering number. Define calibration points for codes Q1, Q2, Q3, Q22 and Q9.

\*) only as a special request after an agreement with the manufacturer

**TABLE 3 – ACCESSORIES - OVERVIEW OF DESIGNS RECOMMENDED NIPPLES –TYPE 991 (order separately)**

SPECIFICATION						ORDERING NUMBER				
						991	xxx	x	xxx	xx
Shape	direct						NVP			
	oblique (chamfer 45°)						NVS			
Internal thread	M20×1,5	with recess for sealing ring	PN	40				1	M20	
	G 1/2							G12		
	M20×1,5	without recess for sealing ring						2	M20	
	G 1/2							G12		
	M27×2			160				4	M27	
	G 3/4						G34			
	3/4 – 14 NPT						N34			
	G1						G01			
other *)									999	
Material	1.0308 or 1.0122	surface treatment	conservation by fat - by oil	maximum operation temperature [°C]	300 (only PN 40)				M20	13
							G12			
							M27			
							G34			
							N34			
			400					G01	15	
			550					M27	51	
							G34			
							N34			
			-		550				72	
			pursuant to material		pursuant to material				99	

\*) only as a special requirement after an agreement with the manufacturer



**TABLE 4 - OVERVIEW OF SEALING RINGS, TYPE 991, SUPPLIED FOR TEMPERATURE SENSORS**

CONNECTING THREAD OF TEMPERATURE SENSORS	SEALING RING			
	DIMENSION [mm] Ød × ØD × t	MATERIAL	NUMBER	ORDERING NUMBER
M20×1.5	21×27×1.5	copper 11 thermal insulating insert	1 pcs	991 TK 21
G1/2				
M27×2	27×32×1.5	copper		991 TK 27
G3/4				
G1	33×39×2	-	-	991 TK 33
3/4-14 NPT	-	-	-	-

The sealing ring is supplied to each sensor by default. The sealing ring can also be ordered separately using ordering number.

**INSTALLATION AND CONNECTION**

**SENSOR INSTALLATION**

Install the sensors by screwing into the nipple on the piping (technological equipment). Before the installation, put on the enclosed sealing ring in advance (for thread 3/4-14NPT, the sealing ring is not used). During the installation, torque of 150 Nm is recommended; 70 Nm for thread 3/4-14NPT.

A proposal of securing the thermowell of the temperature sensors Ex d for nominal lengths exceeding 630 m is in figure 1; examples of installation of direct and angular nipples are in figure 4.

With respect to maintaining metrological properties and the longest possible service life, it is not recommended to install the sensors in places with high turbulence of the medium, which is caused e.g. by a rapid transition from a small diameter of the piping to a larger one (when failing to comply with the required shape and dimensions of diffuser behind the flow meter), etc. Recommended distance of the temperature sensor from the installation flange of the flow meter is min. 1 m.

**ELECTRICAL CONNECTION**

The electrical connection may be only realized by qualified workers.

The terminal board of the sensor (converter) is accessible after tilting the lid of the head, which is connected with one screw. Connect the evaluation devices to the sensor with a non-armoured cable with double insulation with outer diameter from 5 to 8 mm (internal wires with Cu core with the cross section from 0.5 to 1.5 mm<sup>2</sup>. Seal the cable outlet adequately

**! WARNING**

**Do not use independent wires without jacket for electrical connection. To ensure the ingress protection grade in the outlet, the connecting cable shall have circular cross-section. Temperature resistance of the cable shall comply with the ambient temperature!**

The cable insulation shall have chemical and mechanical resistance in compliance with the conditions, in which the cable will be installed. It is recommended supporting the cable along its length between the sensor and the follow-up device. In the environment with interfering signals, use shielded cable in the power supply circuit. Shielding may be only grounded (earthed) in one point. The cable should not be placed together with power cables.

In case of the sensor with HART protocol converter, the maximum length of wiring is defined by the arrangement of wires of the connecting cable. The total length of wiring may be up to 1500 m. It requires a twisted two-wire with shared shielding with the cross section of the core min. 0.5 mm<sup>2</sup>. HART communicator is connected to the supply loop of the sensor with converter pursuant to Figure 3. To achieve reliable communication, total load resistor of min. 250 Ω shall be in the circuit of the output loop.

**INSTALLATION OF THE SENSOR WITH CONVERTER Ex i IN CONDITIONS WITH EXPLOSIVE GASEOUS ATMOSPHERE**

The sensor installation in conditions with explosive gaseous atmosphere shall comply with the requirements of EN 60079-14.

**The sensor without converter** (with ball head from alloy Al with external and internal terminals – only on ZP (special requirement) after an agreement with the manufacturer) can be used as a simple device pursuant to EN 60079-11 Article 5.7 in an intrinsically safe circuit Ex ia pursuant to EN 60079-25. For a simple device, the maximum temperature can be determined from the value of the P0 of the connecting device and the temperature class is determined.

**The sensor with converter Ex ia** may be used in case of compliance with the parameters Ex ia of the converter according to the enclosed converter manual.

Only insulated cables must be used in intrinsically safe circuits which is able to withstand the electrical strength test with a voltage equal to twice the voltage in the intrinsically safe circuit, or 500 V eff (DC 750 V), taking greater of the values. In case of installation of intrinsically safe circuits, including cables, the maximum permitted inductance, capacity or ratio L/R and surface temperature may not be exceeded. Permitted values can be found out in the documentation of the follow-up equipment or label with the designation. Locate the follow-up equipment outside of the dangerous area. An intrinsically safe source must be always used that is approved for power supply of intrinsically safe equipment in the sense of EN 60079-11. If a LED display is required, it must be in the design Ex ia.

**! WARNING** Ex  
**Programmable converter may not be connected to a computer or a HART communicator if the converter is located in explosive environment.**

For installations in dangerous areas, mutual interconnection is required (bringing to the same potential). To achieve it, clamps on the sensor head can be used.

The sensor need not be connected to the system of mutual connection independently if it is installed firmly and has metal interconnection with the structural parts or the piping, which is connected to the system of mutual connection.

**HEAD OF THE SENSOR WITH CLAMPS**

for the sensor with converter Ex i

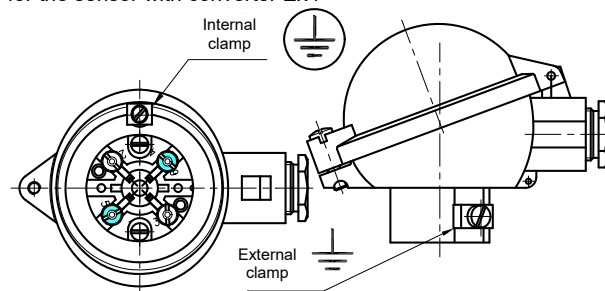

**Maximum cross-section of wire for connection to external and internal clamps:**

Internal clamp: stranded wire 1.5 mm<sup>2</sup>, full wire 2.5 mm<sup>2</sup>

External clamp: stranded wire 4.0 mm<sup>2</sup>, full wire 6.0 mm<sup>2</sup>

If stranded wires are used for the interconnection, they shall be protected against fraying with pressing hollow.

**COMMISSIONING**

After the sensor installation, including closing the fixed closure, and connection of the follow-up (evaluation) device to the supply voltage (and the settlement period of the converter), the equipment is prepared for operation.

**OPERATION AND MAINTENANCE**

The sensor does not require any operation and maintenance. For the sensor in the environment with explosive gaseous atmosphere maintenance and following regular periodic revisions or continuous supervision of professional personnel are carried out compliance with EN 60079-17.

**SENSOR UNINSTALLATION**

Disconnect the sensor from the supply source. The terminal board of the sensor (converter) is accessible after tilting of the lid of the head that is connected with one screw.



Measuring insert of the sensor can be replaced and is removed from the head after disconnecting the cable by releasing two screws.

If the sensor is connected to the system of interconnection, it is necessary to release the wire for mutual interconnection from the terminal on the head of the sensor before the total uninstallation of the sensor.

Screw the sensor from the thermowell; torque is approx. 70 Nm. While releasing the screw union of the sensor, the thermowell may never be released.

**SPARE PARTS**

Spare parts shall be delivered by the manufacturer. Relevant measuring inserts can be ordered pursuant to the following table:

SPECIFICATIONS	ORDERING NUMBER					
	MV240	/xxx/	1	x	x	/xxxx
Length of measuring insert [mm]		purs. to table 1	1			
Sensing probe	Pt100			1		
	Pt500			2		
Tolerance class	A				A	
	B				B	
Connection of the terminal board or converter	Pt100/ /4					/J4
	2xPt/B/2				B	/D2
	2xPt/ /3					/D3
	Pt/ /4 *)		1	1		/J4X
	2xPt/B/2 *)		1	1	B	/D2X
	2xPt/ /3 *)		1	1		/D3X
	1xPt/ /4C converter pursuant to table 1					

\*) Ex ia design

**PURCHASE ORDER EXAMPLE OF MEASURING INSERT**

Resistance measuring insert without converter  
 MV240 /430/ 11B/J4  
 6 pcs

To order the certified measuring inserts, specify the code according to Table 2 – Additional requirements – behind the ordering number.

The measuring inserts are marked according to Article DESIGNATION. Designation is completed with the ordering number.

Each delivery includes

- Delivery note
- Measuring insert pursuant to the purchase order
- Optional accessories to the measuring insert with a programmable converter
  - o Configuration program according to the required converter
  - o Communication modem (for serial port RS 232C) according to the required converter
- Accompanying technical documentation in Czech
  - o Product manual
  - o Product quality and completeness certificate, which also serves as the warranty certificate
  - o EU Declaration of Conformity (for Ex ia design)
  - o Calibration sheet (for calibrated design)

If it is established in the purchase contract or agreed otherwise, the following documentation can be also delivered with the product

- Declaration of Conformity of the supplier according to EN ISO/IEC 17050-1
- EU Declaration of Conformity (for design with converter)
- Copy of EU-Type Examination Certificate pursuant to the Directive No 2014/34/EU (ATEX). for Ex ia design

**FIGURE 1 - PROPOSAL OF SECURING THERMOWELLOF TEMPERATURE SENSORS** (for nominal lengths exceeding 630 mm)

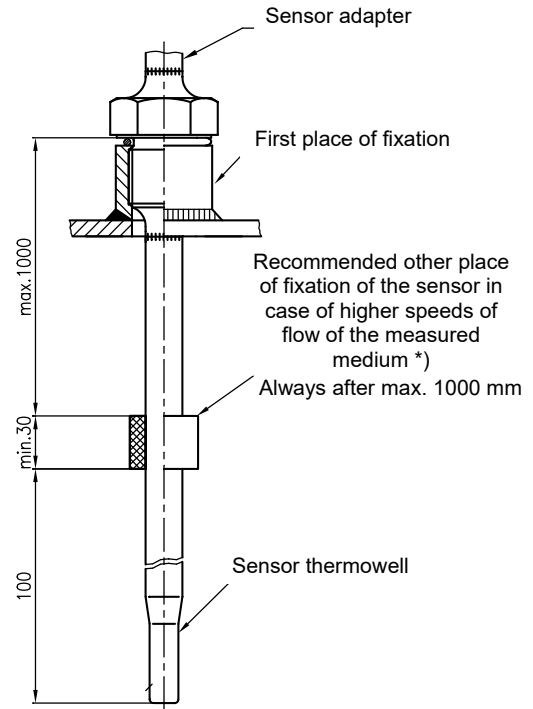

\*) In case of flow of the measured medium, the thermowells are stressed with dynamic effects of the flowing medium and this stress depends on the speed of flow, physical properties of the measured medium and immersion length of the thermowell.

If the occurrence of such dynamic effects can be expected, it is recommended to realize further fixation of the sense or of the thermowell pursuant to the above mentioned proposal.

**WARRANTY**

The warranty period is 24 months from the receiving of the product by the customer, unless established otherwise in the contract. Rejection of defects shall be enforced in writing at the manufacturer within the warranty period. The rejecting side shall identify the product name, ordering and manufacturing numbers, date of issue and number of the delivery note, clear description of the occurring defect and the subject of the claim. If the rejecting side is invited to send the device for repair, it shall do so in the original package of the manufacturer and/or in another package ensuring safe transport.

The warranty shall not apply to defects caused by unauthorized intervention into the device, its forced mechanical damage or failure to comply with operation conditions of the product and the product manual.

**REPAIRS**

The sensors shall be repaired by the manufacturer. They shall be sent for repair in the original or equal package without accessories.

**DISABLING AND LIQUIDATION**

The product and its package do not include any parts that could impact the environment.

The products that are withdrawn from operation, including their packages (with the exception of products marked as electrical equipment for the purposes of return withdrawal and separate salvage of electrical waste), may be disposed of to sorted or unsorted waste pursuant to the type of waste.

The manufacturer realizes free return withdrawal of marked electrical equipment (from 13.8.2005) from the consumer and points out the danger connected with their illegal disposal.

The package of the sensor can be recycled completely. Metal parts of the products are recycled, non-recyclable plastic materials and electrical waste shall be disposed of in accordance with applicable legislation.

**FIGURE 2 – SCHEME OF CONNECTION OF TEMPERATURE SENSORS**  
without converter      with converter      with converter with HART protocol

**J4** - With single measuring resistor in four-wire connection (Pt 100/ /4)

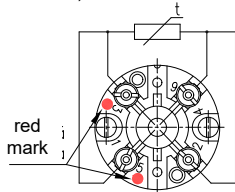

**D2** - With double measuring resistor in two-wire connection (2 × Pt 100/B/2)

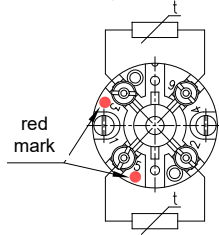

**D3** - With double measuring resistor in three-wire connection (2 × Pt 100/ /3)

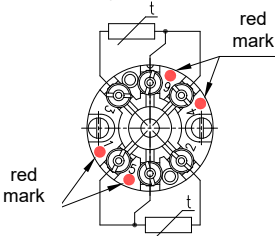

**J2S** - With single measuring resistor in wiring with an auxiliary loop (Pt/ /4C)

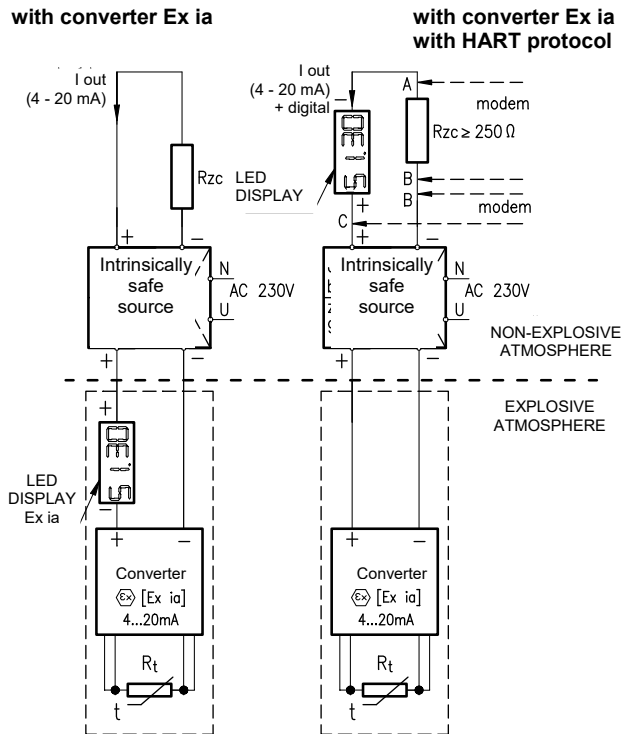
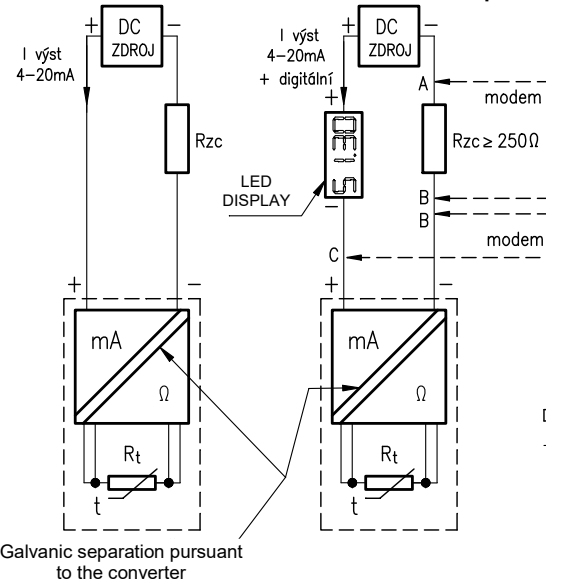
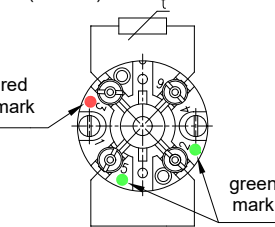

A-B and B-C options of connection of the kontrol unit (HART modem, HART communicator)

Rzc = Total load resistance

**FIGURE 3 - EXAMPLE OF OPERATION CONNECTION OF TEMPERATURE SENSOR WITH CONVERTER IN LOOP 4 - 20 MA**

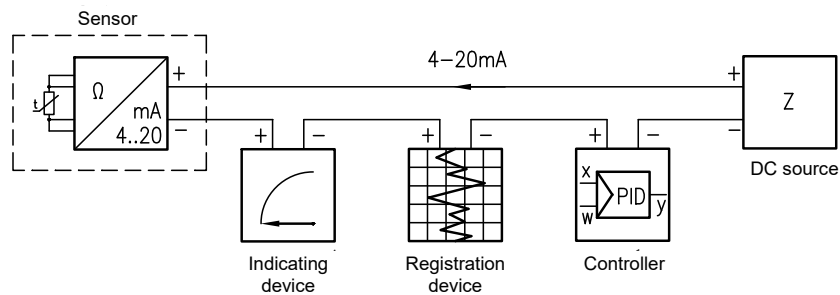
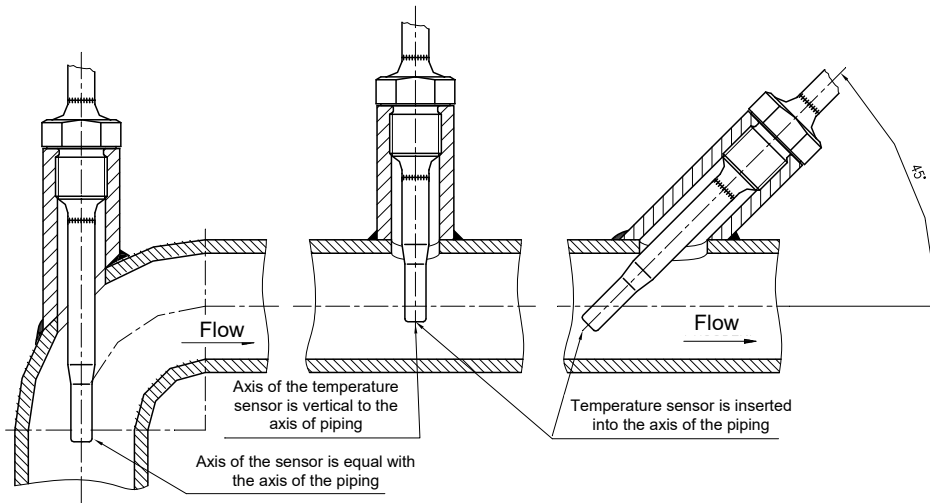

FIGURE 4 - EXAMPLES OF INSTALLATION OF DIRECT AND ANGULAR NIPPLES PURSUANT TO ČSN EN 1434-2



**WARNING**

- When using the sensor with an angular nipple, locate the sensor with thermowell at an angle against the direction of flow
- The sensor may not touch the opposite side of the piping
- It is also advantageous to use the temperature sensors in the piping elbow. In such a case, locate the sensor with the thermowell against the direction of flow so that the measured medium flows around evenly

FIGURE 5 - INTRINSICALLY SAFE MARKING

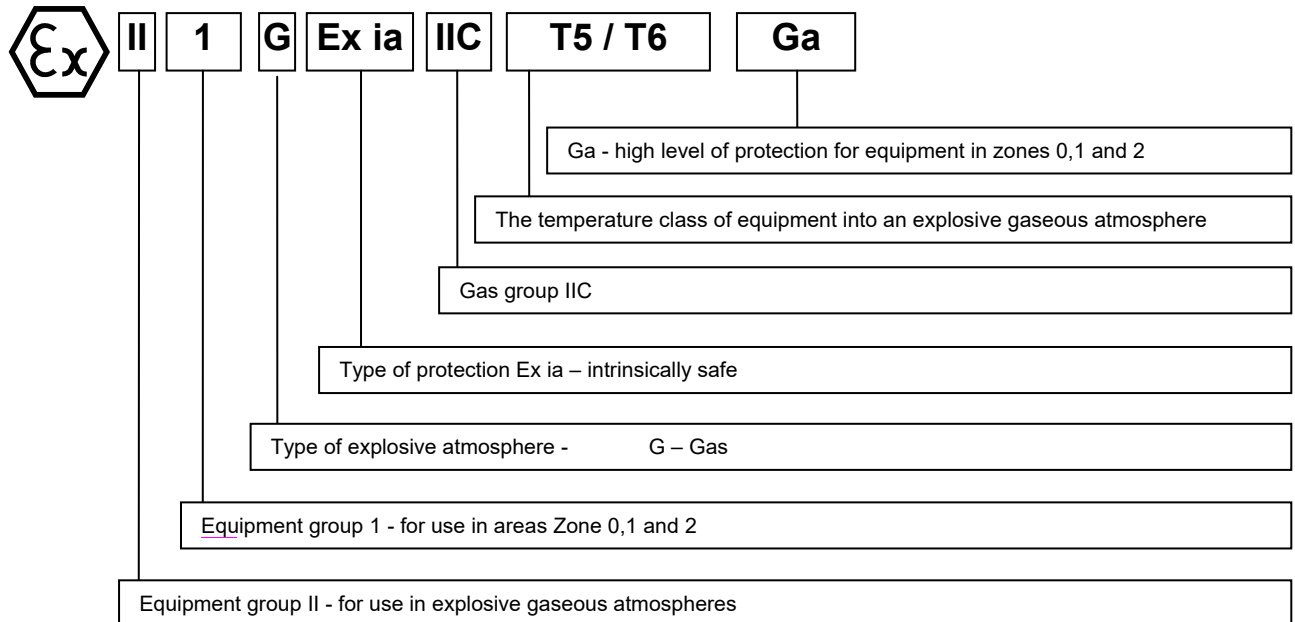

April 2021

© ZPA Nová Paka, a.s.

