

Nominal pressure of thermowell

pursuant to ČSN 13 0010: PN 160

Operation position:

discretionary; the outlet shall not be situated upwards

Type of operation:

continuous

Sensor weight:

with ball head (Al alloy), adapter 150 mm and nominal length 250 mm approx. 0.68 kg

Applied materials:

Thermowell	steel 1.4541 steel 1.4571
Stem tube of measuring insert	steel 1.4541
Adapter	steel 1.4541
HEAD	aluminium alloy painted with polyester paint plastic PPO (phenyl polyoxide)
Sealing of lid of the head	oil resistant rubber
Internal wiring	Cu
Head terminals of the terminal board	brass with Ni surface
Connecting elements of the sensor	stainless steel

OPERATION CONDITIONS

The environment is defined by the group of parameters and their severity grades IE 36 pursuant to EN 60721-3-3 and the following operation conditions.

Ambient temperature for head and outlet of the sensor:

- For design without converter -50 °C to 120 °C
- For design with converter pursuant to the type of the converter (refer to the enclosed converter manual)
- For design with converter and display -20 °C to 70 °C

Vibrations:

Nominal length [mm]	100	160	250	400	630
Frequency range [Hz]	10 to 500				
Drift amplitude [mm]	0.2	0.2	0.15	0.1	0.1
Acceleration amplitude [ms ⁻²]	29.4	29.4	19.6	19.6	19.6

Relative ambient humidity:

10 to 100 % with condensation, with upper limit of water content 29 g H₂O/kg of dry air

Atmospheric pressure: 70 to 106 kPa

Resistance of material of the head PPO (phenyl polyoxide):

Kerosene	partially resistant
Diesel oil	resistant
Benzene	partially resistant
Animal and vegetable oil	resistant
Weak hydroxides	
Strong hydroxides	
Weak acids	
Strong acids	
Sea water	
Trichloroethylene	partially resistant

Resistance of lid sealing material (oil resistant rubber):

Spirit	resistant
Ether	
Benzole	
Petrol	
Ester	
Animal and vegetable oil	
Mineral oil	
Diesel oil	
Weak alkali hydroxides	
Strong alkali hydroxides	
Weak acids	resistant
Strong acids	not resistant
Sea water	resistant
Trichloroethylene	partially resistant
Hot water	

Maximum speed of flow of liquids:

Maximum speed of flow [m/s]	Nominal length [mm]				
	100	160	250	400	630
Water steam and air	50	25	8	2.5	1
Water	5	3	3	1.5	0.2

METROLOGICAL DATA

Sensing probe: measuring resistor Pt 100 in connection pursuant to scheme and table of designs, $\alpha = 0.00385 [K^{-1}]$, tolerance class A or B pursuant to IEC 751

Internal wiring resistance at 20 °C: 0.1 Ω/m

The calculated resistance value of internal wiring of the design without converter is specified on the label of the measuring insert.

Maximum current load of measuring resistor: 3 mA

Recommended measuring current: 1 mA

Output signal of the converter (linear with measured temperature): 4 to 20 mA (+ digital for HART protocol)

Calibration depth of immersion of the measuring insert of the sensor

for temperature points within range -70 to 250°C:
200 mm (min. 160 mm)
for temperature points above 250°C:
300 mm (min. 260 mm)

The distance of flange of the measuring insert from the level of medium in the calibration bath shall be at least 40 mm at temperatures to 250°C and min. 70 mm at temperatures above 250°C.

Temperature response time pursuant to IEC 751 in whirling water (characteristic value):

$\tau_{0.5}$ 29 s
 $\tau_{0.9}$ 95 s

DESIGNATION :

Data on label of head

- Trademark of the manufacturer
- Made in Czech Republic
- Type of resistance sensor, nominal value R_0 / tolerance class / configuration of wires of internal wiring *)
- Measuring range or set-up converter range
- Product ordering number
- Ingress Protection
- Serial number
- Output signal 4 to 20 mA (design with converter)
- Ambient temperature
- Mark of non-explosiveness and number of the EC Type Examination Certificate (for design with converter Ex i)
- CE mark 1015
- CE mark with identification number of the notified person (for design with converter Ex i)

*) Configuration of wires of internal wiring is not specified for the converter

Data on label of measuring insert

- Trade mark
- Sensor type, nominal value R_0 / tolerance class / configuration of wires of internal wiring *)
- Serial number
- Resistance value of internal wiring (for design without converter)

*) Configuration of wires of internal wiring is not specified for the converter

Data on label of converter

- Trademark
- Type of sensor
- Pre-set temperature range
- Designation of non-explosiveness and EU-Type Examination Certificate number (for design with converter Ex i)
- CE mark with identification number of the notified person (for design with converter)

Data on display

- Trademark
- Designation of non-explosiveness and EU-Type Examination Certificate number (for design with converter Ex i)
- CE mark with identification number of the notified person (for design with converter)

CERTIFICATION

- Non-explosiveness Ex i, EU-Type Examination Certificate pursuant to the 2014/34/EU, (pursuant to the type of the converter and display)
- Declaration of metrological conformity (MID) in accordance with Module B of Directive No. 2014/32/EU, EU Type Examination Certificate No. TCM 321/12-4906
- Evaluation certificate. No. ZR 114/10-0068

DELIVERY

Unless agreed otherwise with the customer, each delivery includes

- Delivery note
- Sensor pursuant to the purchase order
- Sealing ring
 - o 21x27 TPD 62-014-91 for thread G½ and M20x1.5
 - o Cu 27 x 32 x1.5 (ČSN 02 9310.2) for thread M27 x 2 and G¾
 - o Cu 33 x 39 x 2 (ČSN 02 9310.2) for thread G1 (for thread 3/4-14NPT the sealing ring is not delivered)
- Suitable nipples ordered separately pursuant to the catalogue of accessories, type 991
- Optional accessories to the sensor with programmable converter
 - o Configuration (parameterization) programme pursuant to the required converter
 - o Communication modem (for serial port RS 232C) pursuant to the required converter
- Accompanying technical documentation in Czech
 - o Product manual
 - o Product quality and completeness certificate, which also serves as the warranty certificate
 - o EU Declaration of Conformity
 - for design with converter Ex i
 - for design with proof of metrological compliance (/M5)
 - o Calibration sheet (for uncertified calibrated design)

If it is established in the purchase contract or agreed otherwise, the following documentation can be also delivered with the product

- Copy of the Inspection Certificate 3.1 for material of stem tube and thermowell with the heat number
- Declaration of Conformity with purchase order 2.1 acc. to EN 10204
- Declaration of Conformity of the supplier pursuant to EN ISO/IEC 17050-1
- Copy of EU-Type Examination Certificate pursuant to the Directive No 2014/34/EU (ATEX). for design with converter Ex ia
- Copy of EU-Type Examination Certificate
- Copy of Evaluation certificate for design /M1, /M2, /M3 and /M4
- Test report about the seismic and the vibration qualification

RELIABILITY

Indicators of reliability in operation conditions and ambient conditions specified herein

- Medium time of operation between failures 96 000 hours (inf. value)

Expected service life 10 years

CALIBRATION

It is realized pursuant to TPM 3342-94 and in compliance with EN 60751, usually in three temperature points spread evenly within the operation range of the sensor or in the points according to the requirement of the customer. Calibration sheets with measured data are issued for calibrated sensors.

PACKING

Both sensors and accessories are delivered in a packing ensuring resistance to the impact of thermal effects and mechanical effects pursuant to controlled packing regulations.

TRANSPORT

The sensors may be transported on conditions corresponding to the set of combinations of classes IE 21 pursuant to EN 60721-3-2 (i.e. by airplanes and trucks, in premises that are ventilated and protected against atmospheric effects).

STORAGE

The sensors may be stored on conditions corresponding to the set of combinations of classes IE 12 pursuant to EN 60721-3-1, but with ambient temperature from -20 to 70 °C (i.e. in places where temperature and humidity are not regulated, with a threat of occurrence of condensation, dripping water and formation of ice, without a special threat of an attack with biological agents, with vibrations of small significance and not situated close to sources of dust and sand).

ASSESSMENT OF CONFORMITY PURSUANT TO THE DIRECTIVE 2014/32 EU

Couple sensors are verified pursuant to EN 1434-5.

The sensors are rated products pursuant to the Directive 2014/32 EU of the European Parliament and the Council and EU Declaration of Conformity is issued for them.

The manufacturer performs subsequent verification under EN 1434-5. Subsequent verification is ordered in the department AMS ZPA N. Paka a.s. (ams@zpanp.cz).

For subsequent verification, send the whole couple tied together.

METHOD OF PLACING THE MARK OF ASSEMBLY AND SERVICE ORGANIZATION AND REINSURANCE MARKS

Verified sensors have a self-adhesive label with reinsurance mark. The label is stuck on the terminal board and the sensor head.

After installation on place of use the sensors will be reassured with mounting seal eventually with label, preventing unauthorized manipulation.

After subsequent verification, the sensors will be provided with a self-adhesive label with an official mark. The label will be stuck on the terminal board and the sensor head instead of the original reinsurance mark.

PLACING THE MARK OF ASSEMBLY AND SERVICE ORGANIZATION AND REINSURANCE MARKS

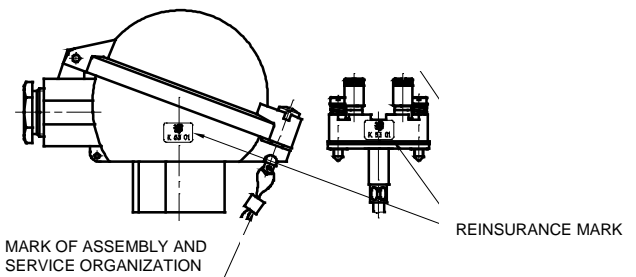

ORDERING TEMPERATURE SENSORS

The purchase order shall specify

- Name
- Product ordering number
- Measuring range
- If calibration is required and in what temperature points
- If the delivery of nipple pursuant to the type 991 is required for the sensor as accessories
- If optional accessories to the sensor with programmable converter are required
- Other (special) requirements
- Number of pieces

Behind the ordering number specified pursuant to the table 1, the customer shall identify the required range of measured temperature (i.e. lower and upper temperature limits in °C) and, as the case may be, other non-standard required parameters for converter configuration (e.g. indication of sensor tripping, dampening, required designation - tagging etc.).

PURCHASE ORDER EXAMPLE

Standard design:

Resistance temperature sensor with thermowell ČSN
Without converter
242 412 331 1B/J4
Range -70 to 600°C
6 pcs

Special request:

Resistance temperature sensor with thermowell ČSN
With converter
242 912 231 1B/18
Nominal length L 380 mm, range 0 to 100°C
6 pcs

ORDERING ACCESSORIES

The purchase order shall specify:

- Name
- Ordering number
- Number of pieces

EXAMPLE OF PURCHASE ORDER**Standard design:**

Nipple
991 NVP4 M27 72
6 pcs

Special request:

Nipple
991 NP4 M27 99
material 1.5415
6 pcs

TABLE 1 - DESIGN OF TEMPERATURE SENSORS WITH THERMOWELL ČSN TYPE 242

SPECIFICATIONS					ORDERING NUMBER																				
					242	x	x	x	x	x	1	x	x	/xxxxxx	/xxx										
Nominal length L [mm]	100	Length of adapter L _n [mm]	150	Length of measuring insert L _{mv} [mm]	280	1	1																		
	160				2																				
	250				3																				
	400				4																				
	630				5																				
	Other (min. 75) *)				9																				
Nominal length L [mm]	100	Length of adapter L _n [mm]	80	Length of measuring insert L _{mv} [mm]	210	1	2																		
	160				2																				
	250				3																				
	400				4																				
	630				5																				
	Other (min. 75) *)				9																				
Length of adapter	150 mm				1																				
	80 mm	max. -70 to 250°C			2																				
	Other **)	(min. 80 mm)			9																				
Thermowell material	1.4571	max. -70 to 400°C								1															
	1.4541	max. -70 to 600°C								2															
	Other *)									9															
Connecting thread	G1/2										1														
	G1										2														
	M27x2										3														
	G3/4										4														
	3/4-14 NPT										5														
	M20x1.5										6														
	Other *)										9														
Sensor head	Ball (Al alloy) (with converter Ex i with external and internal clamps)																								
	Plastic ball (it cannot be used with converter Ex i)																								
	Ball head with increased lid (Al alloy) without display with converter in the lid or with display (with converter Ex i with external and internal clamps)																								
	Small ball (Al alloy) (only for the terminal board and the converters INPAL 420, APAQ-HRF, TH 100, MINIPAQ-HLP) other *)																								
Stem tube of measuring insert for sensor with thermowell																									
Measuring resistor (sensing probe)	Pt100																								
	Pt500 *)																								
Tolerance class	A	guaranteed only within range to 300°C																			A				
	B																				B				
Connection of the terminal board	Single - four-wire (1xPt100/ /4)																				/J4				
	Double- two-wire (2xPt100/B/2)																				B				
	Double- three-wire (2xPt100/ /3)																								
	Single - with auxiliary loop (1xPt/ / 4C)																								
Converter (connection for converter: single, double, three or four-wire, pursuant to the converter)	Converter type		Galvanic separation	Ex	Range [°C]																				
	Analogue	INPAL 420			-50 to 50																	/07			
					-30 to 70																	/55			
					0 to 50																		/15		
					0 to 100																			/18	
					0 to 150																			/19	
					0 to 200																			/20	
					0 to 250																			/21	
			0 to 400				1															/23			
		APAQ-HRF				Adjustable range																/HRF			
		APAQ-HRFX		•																		/HRFX			
	Programmable	TH 100			•																		/TH100		
		TH 100-ex			•																		/TH100X		
		TH 200		•																			/TH200		
		TH 200-ex		•																			/TH200X		
		IPAQ-H		•																			/IPAQH		
		IPAQ-HX		•																			/IPAQHx		
		IPAQ C330		•																			/C300		
	IPAQ C330X		•																			/C300X			
	MINIPAQ-HLP		•																			/MINIPAQ			
	HART protocol	TH 300		•																			/TH300		
		TH 300-ex		•																			/TH300X		
		MESO-H		•																			/MESOH		
MESO-HX			•																			/MESOHx			
248 HA NA			•																			/248HANA			
248 HA I1			•																			/248HA1X			
644 HA NA		•																			/644HANA				
644 HA I1		•																			/644HA1X				
Other *)																					/99				
Without converter (for installation of the converter by the customer)																						/00			
LED display to loop 4-20mA	LED display LPI-01 (only with converter, except of converter 644 HANA)																					/LD			
	LED display Ex ia *) (only with converter Ex ia , except of converter 644 HA1X)																						/LDX		

Standard design

*) Only as a special request after an agreement with the manufacturer

**) In case of adapter length below 150 mm (minimum 80 mm), the temperature range is decreased to -70 to 250 °C

TABLE 2 – ADDITIONAL REQUIREMENT FOR DESIGN OF TEMPERATURE SENSORS WITH THERMOWELL ČSN TYPE 242

SPECIFICATIONS				CODE	
PROOF OF METROLOGICAL COMPLIANCE	DESIGN OF TEMPERATURE SENSORS	MEASURING RANGE [°C]	USE		
Proof of metrological compliance pursuant to Directive No. 2014/32/EU (MID), Annex MI-004 *)	couple sensors without converter in connection 1xPt100/..1/4 min. length of measuring insert Ø 6 mm = 210 mm min. immersion = 160 mm	0 to 180	application for residential and business premises and for the light industry	/M5	
CALIBRATION (for sensors as described below)	DESIGN OF TEMPERATURE SENSORS	MEASURING RANGE [°C]	USE		
Calibration by TPM 3342-94, in three calibration points evenly distributed in the sensor measuring range for use as part of the customer's measurement assemblies pursuant to Directive No. 2014/32/EU (MID), Annex MI-002 and MI-005 *)	sensors without converter in connection 1xPt100/..1/4 min. length of measuring insert for temperature to 250°C Ø 6 mm = 210 mm for temperature over 250°C Ø 6 mm = 275 mm	-50 to 50	application for residential and business premises and for the light industry	/M1	
		-50 to 100		/M2	
		0 to 200		/M3	
		0 to 250 for sensors with extension lengths shorter than 140 mm (min. 80 mm)		/M4	
		0 to 300 for sensor with measuring resistance in tolerance class A			
0 to 400 for sensors with extension lengths 140 mm and longer, with measuring resistance in tolerance class B					
CALIBRATION	NUMBER OF CALIBRATION POINTS	CALIBRATION RANGE			
Calibration by TPM 3342-94, define calibration points	3	0 to 420 °C	/Q1		
	3	0 to 600 °C	/Q2		
	3	-50 to 600 °C	/Q22		
	Other	-50 to 600 °C	/Q9		
REQUIREMENT FOR OTHER DOCUMENTATION			USE		
Copy of EU-Type Examination Certificate (pursuant to Directive No. 2014/32/EU)			M5	/MID	
Copy of Evaluation certificate No. ZR 141/10-0068			M1, M2, M3, and M4	/EC	
EU Declaration of Conformity			for design with converter	/EU	
Copy of EU-Type Examination Certificate acc to the 2014/34/EU (ATEX)			for converter and display Ex ia	/Exi	
Copy of the Inspection Certificate 3.1 acc to EN 10204 for material of tube with the heat number				/3.1	
Declaration of Conformity with purchase order 2.1 pursuant to EN 10204				/2.1	

Specify the code behind ordering number. Define calibration points for codes Q4, Q42 a Q9.

*) only as a special request after an agreement with the manufacturer

TABLE 3 – ACCESSORIES - OVERVIEW OF DESIGNS RECOMMENDED NIPPLES –TYPE 991 (order separately)

SPECIFICATION					ORDERING NUMBER							
					991	xxx	x	xxx	xx			
Shape	direct											
	oblique (chamfer 45°)											
Internal thread	M20x1,5	with recess for sealing ring	PN	40								
	G 1/2						1	M20				
	M20x1,5	without recess for sealing ring										
	G 1/2						2	M20				
	M27x2											
	G 3/4											
	3/4 – 14 NPT											
	G1											
other *)												
Material	1.0308 or 1.0122	surface treatment	conservation by fat - by oil	maximum operation temperature [°C]	300 (only PN 40)							
	1.0577											
	15 128.5											
	1.4541											
	other *)											

*) only as a special requirement after an agreement with the manufacturer

TABLE 4 - OVERVIEW OF SEALING RINGS, TYPE 991, SUPPLIED FOR TEMPERATURE SENSORS

CONNECTING THREAD OF TEMPERATURE SENSORS	SEALING RING			
	DIMENSION [mm] Ød × ØD × t	MATERIAL	NUMBER	ORDERING NUMBER
M20x1.5	21×27×1.5	copper 11 thermal insulating insert	1 pcs	991 TK 21
G1/2				
M27x2	27×32×1.5	copper		991 TK 27
G3/4				
G1	33×39×2	-	-	991 TK 33
3/4-14 NPT	-	-	-	-

The sealing ring is supplied to each sensor by default. The sealing ring can also be ordered separately using ordering number.

INSTALLATION AND CONNECTION

SENSOR INSTALLATION

Install the sensors by screwing into the nipple on the piping (technological equipment). Before the installation, put on the enclosed sealing ring in advance (for thread 3/4-14NPT, the sealing ring is not used). During the installation, torque of 150 Nm is recommended; 70 Nm for thread 3/4-14NPT.

A proposal of securing the thermowell of the temperature sensors Ex d for nominal lengths exceeding 630 m is in figure 1; examples of installation of direct and angular nipples are in figure 2.

With respect to maintaining metrological properties and the longest possible service life, it is not recommended to install the sensors in places with high turbulence of the medium, which is caused e.g. by a rapid transition from a small diameter of the piping to a larger one (when failing to comply with the required shape and dimensions of diffuser behind the flow meter), etc. Recommended distance of the temperature sensor from the installation flange of the flow meter is min. 1 m.

ELECTRICAL CONNECTION

The electrical connection may be only realized by qualified workers.

The terminal board of the sensor (converter) is accessible after tilting the lid of the head, which is connected with one screw.

Connect the evaluation devices to the sensor with a non-armoured cable with double insulation with outer diameter from 5 to 8 mm (internal wires with Cu core with the cross section from 0.5 to 1.5 mm²). Seal the cable outlet adequately



WARNING

Do not use independent wires without jacket for electrical connection. To ensure the ingress protection grade in the outlet, the connecting cable shall have circular cross-section. Temperature resistance of the cable shall comply with the ambient temperature!

The cable insulation shall have chemical and mechanical resistance in compliance with the conditions, in which the cable will be installed. It is recommended supporting the cable along its length between the sensor and the follow-up device. In the environment with interfering signals, use shielded cable in the power supply circuit. Shielding may be only grounded (earthed) in one point. The cable should not be placed together with power cables.

In case of the sensor with HART protocol converter, the maximum length of wiring is defined by the arrangement of wires of the connecting cable. The total length of wiring may be up to 1500 m. It requires a twisted two-wire with shared shielding with the cross section of the core min. 0.5 mm². HART communicator is connected to the supply loop of the sensor with converter pursuant to Figure 4. To achieve reliable communication, total load resistor of min. 250 Ω shall be in the circuit of the output loop.

INSTALLATION OF THE SENSOR WITH CONVERTER Ex i IN CONDITIONS WITH EXPLOSIVE GASEOUS ATMOSPHERE

The sensor installation in conditions with explosive gaseous atmosphere shall comply with the requirements of EN 60079-14.

The sensor without converter (with ball head from alloy Al with external and internal terminals – only on ZP (special requirement) after an agreement with the manufacturer) can be used as a simple device pursuant to EN 60079-11 Article 5.7 in an intrinsically safe circuit Ex ia pursuant to EN 60079-25. For a simple device, the maximum temperature can be determined from the value of the P0 of the connecting device and the temperature class is determined.

The sensor with converter Ex ia may be used in case of compliance with the parameters Ex ia of the converter according to the enclosed converter manual.

Only insulated cables must be used in intrinsically safe circuits which is able to withstand the electrical strength test with a voltage equal to twice the voltage in the intrinsically safe circuit, or 500 V eff (DC 750 V), taking greater of the values.

In case of installation of intrinsically safe circuits, including cables, the maximum permitted inductance, capacity or ratio L/R and surface temperature may not be exceeded. Permitted values can be found out in the documentation of the follow-up equipment or label with the designation. Locate the follow-up equipment outside of the dangerous area. An intrinsically safe source must be always used that is approved for power supply of intrinsically safe equipment in the sense of EN 60079-11. If a LED display is required, it must be in the design Ex ia.



WARNING

Programmable converter may not be connected to a computer or a HART communicator if the converter is located in explosive environment.



For installations in dangerous areas, mutual interconnection is required (bringing to the same potential). To achieve it, clamps on the sensor head can be used.

The sensor need not be connected to the system of mutual interconnection independently if it is installed firmly and has metal interconnection with the structural parts or the piping, which is connected to the system of mutual connection.

HEAD OF THE SENSOR WITH CLAMPS

for the sensor with converter Ex i

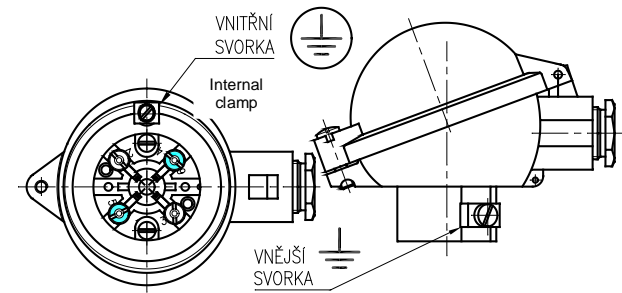

Maximum cross-section for connection to external and internal clamps:

Internal clamp: stranded wire 1.5 mm², full wire 2.5 mm²

External clamp: stranded wire 4.0 mm², full wire 6.0 mm²

If stranded wires are used for the interconnection, they shall be protected against fraying with pressing hollow.

COMMISSIONING

After the sensor installation, including closing the fixed closure, and connection of the follow-up (evaluation) device to the supply voltage (and the settlement period of the converter), the equipment is prepared for operation.

OPERATION AND MAINTENANCE

The sensor does not require any operation and maintenance. For the sensor in the environment with explosive gaseous atmosphere maintenance and following regular periodic revisions or continuous supervision of professional personnel are carried out compliance with EN 60079-17.

SENSOR UNINSTALLATION

Disconnect the sensor from the supply source.

The terminal board of the sensor (converter) is accessible after tilting of the lid of the head that is connected with one screw. Measuring insert of the sensor can be replaced and is removed from the head after disconnecting the cable by releasing two screws.

If the sensor is connected to the system of interconnection, it is necessary to release the wire for mutual interconnection from the terminal on the head of the sensor before the total uninstallation of the sensor.

Screw the sensor from the thermowell; torque is approx. 70 Nm. While releasing the screw union of the sensor, the thermowell may never be released.

SPARE PARTS

Spare parts shall be delivered by the manufacturer. Relevant measuring inserts can be ordered pursuant to the following table:

SPECIFICATIONS	ORDERING NUMBER					
	MV240	/xxx/	1	x	x	/xxxx
Length of measuring insert [mm]		purs. to table 1	1			
Sensing probe	Pt100			1		
	Pt500			2		
Tolerance class	A				A	
	B				B	
Connection of the terminal board or converter	Pt100/ /4					/J4
	2xPt/B/2					/D2
	2xPt/ /3					/D3
	1xPt/ /4C					/J2S
	converter pursuant to tab. 1					/converter

EXAMPLE OF PURCHASE ORDER OF MEASURING INSERT

Resistance measuring insert without converter
 MV240 /430/ 11B/J4
 6 pcs

To order the certified measuring inserts, specify the code according to Table 2 – Additional requirements – behind the ordering number.

The measuring inserts are marked according to Article DESIGNATION. Designation is completed with the ordering number.

Each delivery includes

- Delivery note
- Measuring insert pursuant to the purchase order
- Optional accessories to the measuring insert with a programmable converter
 - o Configuration program according to the required converter
 - o Communication modem (for serial port RS 232C) according to the required converter
- Accompanying technical documentation in Czech
 - o Product manual
 - o Product quality and completeness certificate, which also serves as the warranty certificate
 - o EU Declaration of Conformity (for design with converter Ex ia)
 - o Calibration sheet (for calibrated design)

If it is established in the purchase contract or agreed otherwise, the following documentation can be also delivered with the product

- Declaration of Conformity of the supplier according to EN ISO/IEC 17050-1
- EU Declaration of Conformity (for design with converter)
- Copy of EU-Type Examination Certificate pursuant to the Directive No 2014/34/EU (ATEX). for design with converter Ex ia

FIGURE 1 - PROPOSAL OF SECURING THERMOWELLOF TEMPERATURE SENSORS (for nominal lengths exceeding 630 mm)

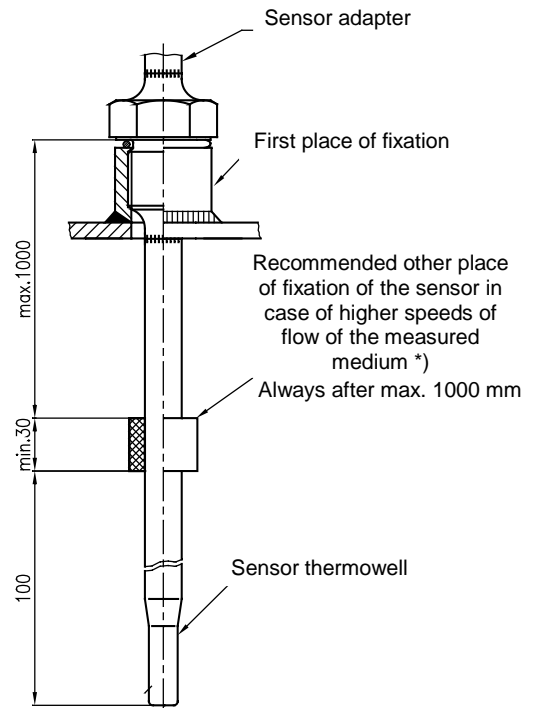

*) In case of flow of the measured medium, the thermowells are stressed with dynamic effects of the flowing medium and this stress depends on the speed of flow, physical properties of the measured medium and immersion length of the thermowell.

If the occurrence of such dynamic effects can be expected, it is recommended to realize further fixation of the sense or of the thermowell pursuant to the above mentioned proposal.

WARRANTY

The warranty period is 24 months from the receiving of the product by the customer, unless established otherwise in the contract. Rejection of defects shall be enforced in writing at the manufacturer within the warranty period. The rejecting side shall identify the product name, ordering and manufacturing numbers, date of issue and number of the delivery note, clear description of the occurring defect and the subject of the claim. If the rejecting side is invited to send the device for repair, it shall do so in the original package of the manufacturer and/or in another package ensuring safe transport.

The warranty shall not apply to defects caused by unauthorized intervention into the device, its forced mechanical damage or failure to comply with operation conditions of the product and the product manual.

REPAIRS

The sensors shall be repaired by the manufacturer. They shall be sent for repair in the original or equal package without accessories.

DISABLING AND LIQUIDATION

The product and its package do not include any parts that could impact the environment.

The products that are withdrawn from operation, including their packages (with the exception of products marked as electrical equipment for the purposes of return withdrawal and separate salvage of electrical waste), may be disposed of to sorted or unsorted waste pursuant to the type of waste.

The manufacturer realizes free return withdrawal of marked electrical equipment (from 13.8.2005) from the consumer and points out the danger connected with their illegal disposal.

The package of the sensor can be recycled completely. Metal parts of the products are recycled, non-recyclable plastic materials and electrical waste shall be disposed of in accordance with applicable legislation.

FIGURE 2 - EXAMPLES OF INSTALLATION OF DIRECT AND ANGULAR NIPPLES PURSUANT TO ČSN EN 1434-2

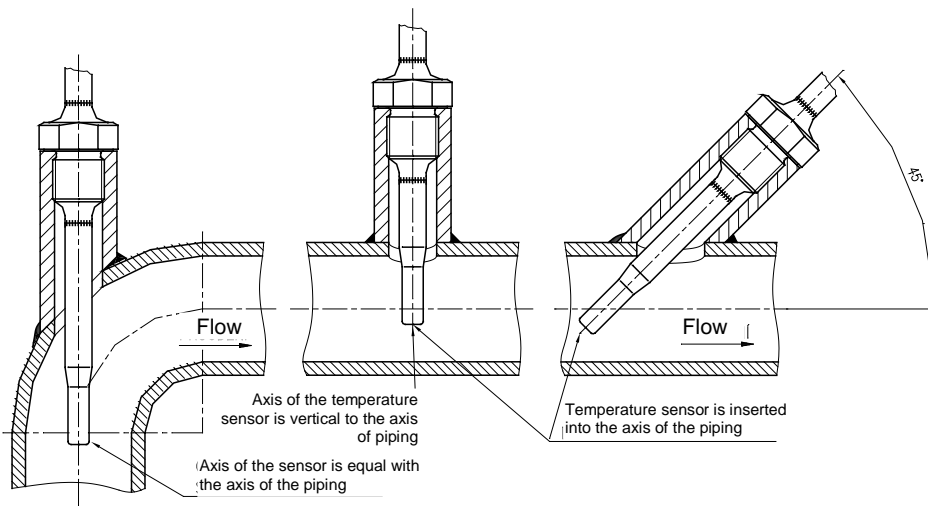

- WARNING**
- When using the sensor with an angular nipple, locate the sensor with thermowell at an angle against the direction of flow
 - The sensor may not touch the opposite side of the piping
 - It is also advantageous to use the temperature sensors in the piping elbow. In such a case, locate the sensor with the thermowell against the direction of flow so that the measured medium flows around evenly

FIGURE 3 – SCHEME OF CONNECTION OF TEMPERATURE SENSORS without converter with converter with converter with HART protocol

J4 - With single measuring resistor in four-wire connection (Pt 100/ /4)

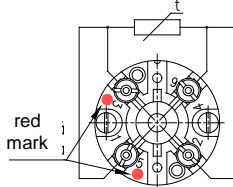

D2 - With double measuring resistor in two-wire connection (2 x Pt 100/B/2)

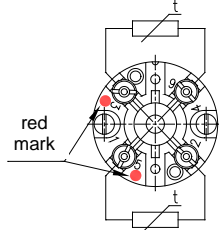

D3 - With double measuring resistor in three-wire connection (2 x Pt 100/ /3)

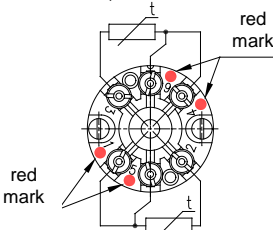

J2S - With single measuring resistor in wiring with an auxiliary loop (Pt/ /4C)

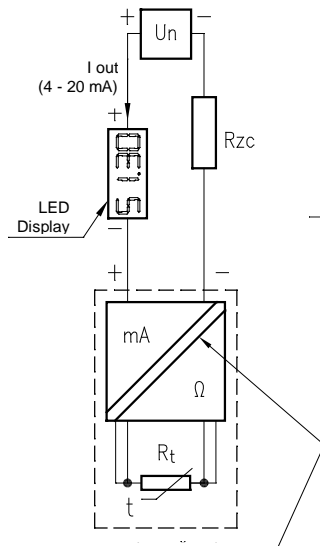
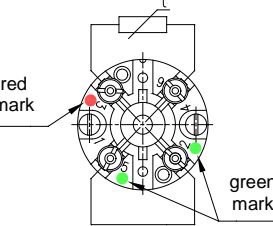

with converter Ex ia

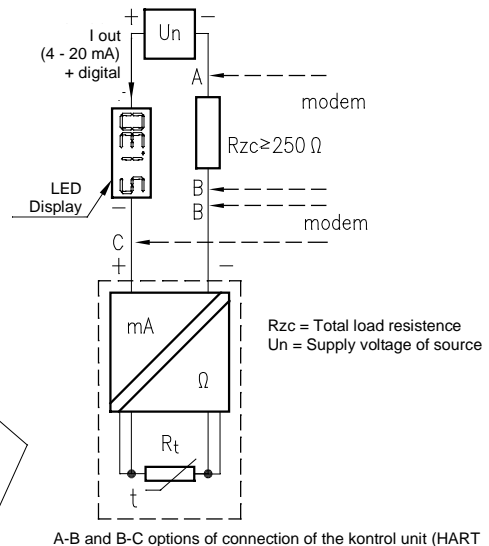

A-B and B-C options of connection of the control unit (HART)

Rzc = Total load resistance
Un = Supply voltage of source

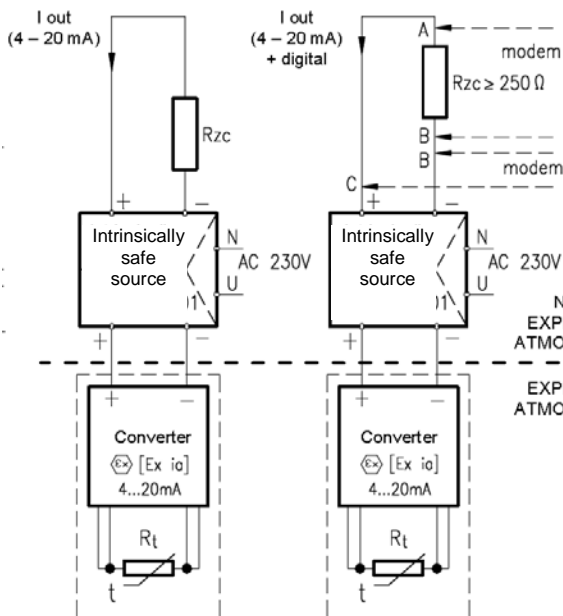

Rzc = total load resistor

FIGURE 4 - EXAMPLE OF OPERATION CONNECTION OF TEMPERATURE SENSOR WITH CONVERTER IN LOOP 4 - 20 MA

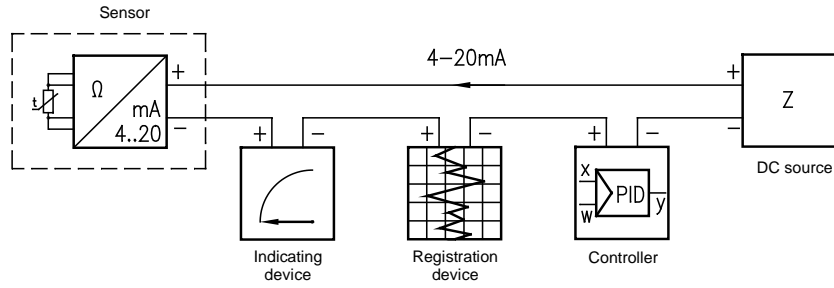

Jun 2018

© ZPA Nová Paka, a.s.



Notified Person No
by Type of Converter



M18 1383