



Resistance temperature sensor for food industry

PRODUCT MANUAL

type 222

APPLICATION

- For measurement of temperature in the core (inside) foods in order to monitor heating or cooling the product, especially for smoke houses, digester houses, baking ovens, cool chambers and choppers even in the places where the sensor is subjected to high mechanical load;
- Also for mobile means that distribute foods;
- For general monitoring of space temperatures and temperatures of liquid and loose media also outside food applications.

DESCRIPTION

With respect to the above mentioned application, the sensor has completely stainless structure. It consists of a reduced stem, which is terminated either with a stabbing tip or a ball terminal and Teflon handle for simple handling. The sensor has an outlet in the form of thermally resistant flexible cable. Due to high Ingress protection grade, the whole surface of the sensor can be washed with running water easily. To measure temperature, a defined change of sensor resistance in dependence on the change of temperature of the measured environment is used.

TECHNICAL DATA

The design of the sensor corresponds to EN 1434-2. The sensor is designed pursuant to EN 61140 as an electrical equipment of protection class III for application in networks with the category of overvoltage in the installation II and pollution grade 2 pursuant to EN 61010-1; the follow-up (evaluation) device shall comply with Article 6.3 thereof.

Measuring range: -50 to 200 °C
Electric strength pursuant to EN 61010-1, Article 6.8.3:
 500 V eff

Electric insulation resistance pursuant to EN 60751:
 min. 100 MΩ, at 15 to 35°C, max. 80 % relative humidity,
 min 100 V DC

Ingress protection pursuant to EN 60529: IP 68
Operation position: discretionary
Type of operation: continuous

Applied materials:

Sensor body and thermowell steel 1.4541 polished
 Inner wiring Cu
 Cable outlet Cu cores with isolation from fluoroplastic material, external isolation fluoroplastic material, shielding with Cu wire
 Handle Teflon

OPERATION CONDITIONS

The environment is defined by the group of parameters and their severity grades IE 36 pursuant to EN 60721-3-3 and the following operation conditions.

Temperature at cable outlet from sensor:
 continually -50 to 180 °C

Relative ambient humidity:
 10 to 100 % with condensation, with upper limit of water content 29 g H₂O/kg of dry air

Atmospheric pressure: 70 to 106 kPa

Minimum immersion in core of foods (in measured medium): 50 mm

Vibrations: Frequency range 10 to 500 Hz
 Drift amplitude 0.2 mm
 Acceleration amplitude 29.0 ms⁻²

METROLOGICAL DATA

Sensing probe: single or double measuring resistor in connection pursuant to the scheme of connection and table of designs
 Pt 100, Pt 500 or Pt 1000, $\alpha = 0.00385 [K^{-1}]$, tolerance class B (or A only for 4-wire) pursuant to EN 60751

Internal wiring resistance at 20 °C
 2 x 0.22 mm²: 2x0.0873 Ω/m

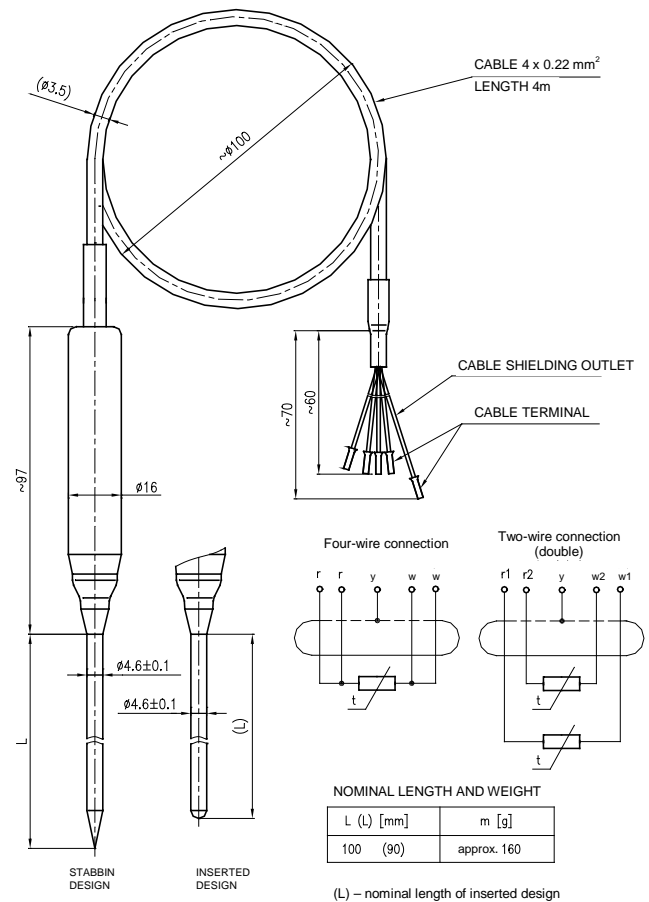

Maximum current load of measuring resistor:

Pt 100 3 mA
 Pt 500 2 mA
 Pt 1000 1 mA

Recommended measuring current:

Pt 100 1.0 mA
 Pt 500 0.5 mA
 Pt 1000 0.1 mA

Self-heating effect:

max. 0.10 °C/mW (i.e. min. 10 mW/°C)

Calibration depth of immersion: 100 mm

Temperature response time pursuant to EN 60751:

Environment	τ _{0.5}	τ _{0.9}
in whirling water	3.0 s	7.5 s
in stable air	1.5 s	6.5 s

RELIABILITY

Indicators of reliability in operation conditions and ambient conditions specified herein

- Medium time of operation between failures 96 000 hours (inf. value)

Expected service life 10 years

DESIGNATION

Data on the sensor

- Trademark of the manufacturer
- Made in Czech Republic
- Type of resistance sensor, nominal value R₀ / tolerance class / configuration of wires of internal wiring
- Measuring range
- Ingress protection
- Production time code

DELIVERY

Unless agreed otherwise with the customer, each delivery includes:

- Delivery note
- Sensor pursuant to the purchase order
- Accompanying technical documentation in Czech:
 - o Product manual
 - o Product quality and completeness certificate, which also serves as the warranty certificate
 - o Calibration sheet (for calibrated design)

If it is established in the purchase contract or agreed otherwise, the following documentation can be also delivered with the product:

- o Copy of the Inspection Certificate 3.1 for the thermowell with the heat number

ORDERING

The purchase order shall specify:

- Name
- Product ordering number
- If calibration is required and in what temperature points
- Other (special) requirements
- Number of pieces

PURCHASE ORDER EXAMPLE

Standard design

1. Stabbing resistance temperature sensor for food industry
222 117 1
15 pcs
2. Inserted resistance temperature sensor for food industry
222 127 9/2500
15 pcs
We require calibration of the sensor in points 0, 50 and 100 °C, including the calibration sheet.

Special requirement:

Stabbing resistance temperature sensor for food industry
222 914 1
15 pcs
Nominal length of stem 175 mm
Measuring resistor 2x Pt1000/B2

CALIBRATION

It is realized pursuant to TPM 3342-94 and in compliance with EN 60751, usually in three temperature points evenly distributed within the operation range of the sensor or in the points according to the requirement of the customer. Calibration sheets with measured data are issued for calibrated sensors.

DESIGN OF TEMPERATURE SENSORS

SPECIFICATION				ORDERING NUMBER							
				222	x	x	x	x	/xxxx		
Nominal length of stem [mm] stabbing design	100	Nominal length of stem [mm] inserted design	90		1						
	150		140		2						
	200		190		3						
	Other *				9						
Design	Stabbing					1					
	Inserted					2					
Measuring resistor	Pursuant to EN 60751 tolerance class B or A*) **)	Pt 1000/ /4					3				
		2 x Pt 1000/B/2					4				
		Pt 500/ /4						5			
		2 x Pt 500/B/2						6			
		Pt 100/ /4							7		
		2 x Pt 100/B/2							8		
	Other *)							9			
Cable length [mm]	Standard cable length 4000 mm (slash and length behind slash are not specified)								1		
	Optional cable length pursuant to data behind slash								9	/xxxx	

*) Only as a special request after an agreement with the manufacturer

**) Measuring resistor in tolerance class A only in four-wire connection

PACKING

Both sensors and accessories are delivered in a packing ensuring resistance to the impact of thermal effects and mechanical effects pursuant to controlled packing regulations.

TRANSPORT

The sensors may be transported on conditions corresponding to the set of combinations of classes IE 21 pursuant to EN 60721-3-2 (i.e. by airplanes and trucks, in premises that are ventilated and protected against atmospheric conditions).

STORAGE

The sensors may be stored on conditions corresponding to the set of combinations of classes IE 11 pursuant to EN 60721-3-1 (i.e. in places with continuous temperature regulation from 5 to 40 °C and humidity from 5 to 85%, without a special threat of an attack with biological agents, with vibrations of small significance and not situated close to sources of dust and sand)

INSTALLATION AND CONNECTION

The sensors are installed by stabbing into the core of foods or by immersing into the measured medium. The minimum immersion is approx. 50 mm. The operation position is discretionary. The basic position is considered the vertical one with the cable outlet facing upwards. Support the outlet cable of the sensor. The sensor, including the handle, is not designed for immersion into boiling boilers.

The electrical connection may be only realized by qualified workers.

COMMISSIONING

After the installation of the sensor and connection of the follow-up (evaluation) device to the supply voltage, the equipment is prepared for operation

OPERATION AND MAINTENANCE

The sensor does not require any special maintenance. After removing it from the measured medium, it is suitable to wash the sensor with water with common degreasing (cleaning) preparation. After the end of application of the stabbing sensor, cover the tip with the safety rubber cover; pay attention to avoid an injury caused by the sharp tip of the stabbing sensor.

SPARE PARTS

The sensor design does not require any delivery of spare parts.

WARRANTY

The warranty period is 24 months from the receiving of the product by the customer, unless established otherwise in the contract. Rejection of defects shall be enforced in writing at the manufacturer within the warranty period. The rejecting side shall identify the product name, ordering and manufacturing numbers, date of issue and number of the delivery note, clear description of the occurring defect and the subject of the claim. If the rejecting side is invited to send the device for repair, it shall do so in the original package of the manufacturer and/or in another package ensuring safe transport.

The warranty shall not apply to defects caused by unauthorized intervention into the device, its forced mechanical damage or failure to comply with operation conditions of the product and the product manual.

REPAIRS

The sensors shall be repaired by the manufacturer. The sensors shall be sent for repair in the original or equal package without accessories.

DISABLING AND LIQUIDATION

The product and its package do not include any parts that could impact the environment.

Products that are withdrawn from operation, including their packages (with the exception of products marked as electrical equipment for the purposes of return withdrawal and separate salvage of electrical waste), may be disposed of to sorted or unsorted waste pursuant to the type of waste.

The manufacturer realizes free return withdrawal of marked electrical equipment (from 13.8.2005) from the consumer and points out the danger connected with their illegal disposal.

The package of the sensor can be recycled completely.

Metal parts of the products are recycled, non-recyclable plastic materials and electrical waste shall be disposed of in accordance with applicable legislation.

March 2019

© ZPA Nová Paka, a.s.

