



# Resistance temperature sensor Ex d to thermowell DIN without converter or with converter type series 230 type 233

## PRODUCT MANUAL

FOR DESIGNS WITH CONVERTER A MANUAL IS ENCLOSED TO THE RELEVANT CONVERTER  
FOR DESIGNS WITH CONVERTER AND DISPLAY A MANUAL IS ENCLOSED TO THE RELEVANT CONVERTER AND DISPLAY

### APPLICATION

- For exact remote measurement of temperature of steady and running liquids (gases and fluids), for which the properties of the thermowell of the sensor selected by the customer are suitable; measurement may be realized up to temperature (max. 450°C) and pressure determined by thermowell resistance
- for environment with explosive gaseous atmosphere according to EN 60079-10-1 and explosive atmospheres with combustible dust according to EN 60079-10-2
  - o Sensor may be installed into the thermowell located in zone 0 (20), zone 1 (21) or zone 2 (22), the thermowell for zone 0 shall comply with the requirements of EN 60079-26 ed. 2 (refer to figure 2)
  - o Other parts of the sensor (screw joint, adapter, connecting head) may be located in zone 1 (21) or zone 2 (22)
  - o Sensor without converter or converter with Ex ia version, when connected to Ex ia circuit according to EN 60079-25 in zone 0, 1, 2, 20, 21 and 22
- In a set with control or diagnostic systems for process monitoring
- In design with converter for transfer of resistance sensor signal to unified output signal 4 to 20 mA or digital signal (converter with HART protocol)
- In design with display to display the value of the measured value
- For the environment, where mechanical resistance is required pursuant to EN 60068-2-6 (class AH2) and seismic capability of the electrical equipment of the safety system of the nuclear power stations pursuant to IEC 980 (MVZ level SL-2)

The sensors with converter are rated products pursuant to the Directive 2014/34/EU, 2014/30/EU of the European Parliament and the Council and EU Declaration of Conformity **EU -233000** is issued for them.

For use temperature sensors as separate assemblies of the heat meter on placing on the market.

The sensors are rated products pursuant to the Directive 2014/32 EU of the European Parliament and the Council and EU Declaration of Conformity **EU-MID-233000-EN** is issued for them.

**Using sensors within the meaning of Directive 2014/32 EU of the European Parliament and the Council. (MID) as part of the customer's measurement kits, for which the conformity of the assemblies as a whole must be assessed when placed on the market with all the features required by this directive:**

- sensor without transmitter in 1xPt100 /.. / 4 connection can be used by the customer on the basis of an evaluation certificate in its measuring sets in the sense of Directive 2014/32 EU of the European Parliament and the Council

### DESCRIPTION

The sensor consists of a replaceable measuring insert with a flange and ceramic terminal board or installed two-wire converter (insulated or non-insulated, even in design Ex ia) and protective armature, consisting of a head and an adapter with a screw joint for the connection of the sensor into the thermowell selected by the customer. The head with measuring insert and gland form a fixed closure Ex d. It is provided with a lid, which can be screwed, and a gland for the connecting wiring. The gland (pursuant to the required diameter of the cable) forms optional accessories to the sensor. The terminal board (of the converter) of the sensor is accessible after unscrewing the lid of the head, which is fixed, after being tightened, with a pin against spontaneous releasing. The sensor is provided with an external terminal and an internal terminal on the head for the connection of the grounding wire or the wire for mutual interconnection.

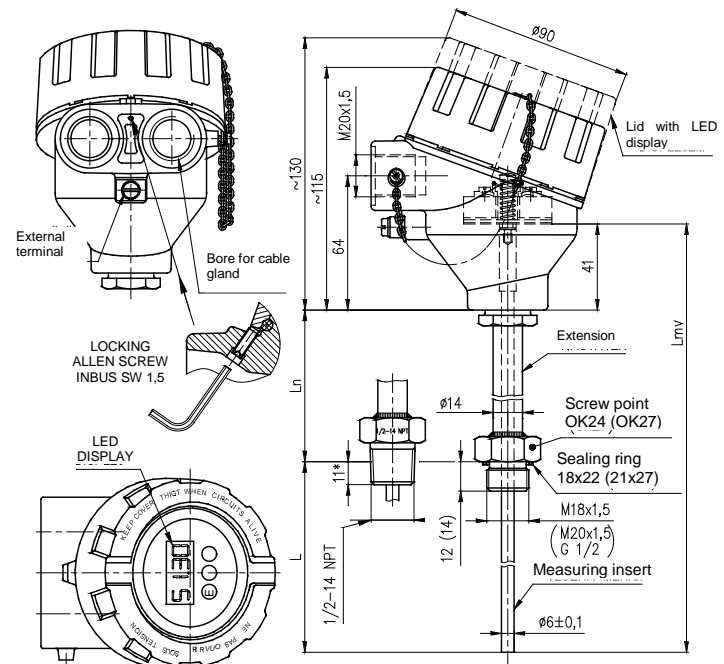

$L$	Nominal length
$L_n$	Length of adapter
$L_{mv}$	Length of measuring insert
11*	Standard length of screwing in

The sensor with converter is supplied from an external source. The installed converter is pre-set to the required range at the sensor manufacturer.

To measure temperature, a defined change of sensor resistance in dependence on the change of temperature of the measured environment is used.

### TECHNICAL DATA

The sensor design is based on DIN 43772. The sensor is designed pursuant to EN 61140 ed.2 as an electric equipment of protection class III for the application in networks with category of overvoltage in installation II and pollution grade 2 pursuant to EN 61010-1; the follow-up (evaluation) device shall comply with Article 6.3 of the said standard.

#### Measuring range:

Sensor with standard adapter	$L_n = 135 (125) \text{ mm}$	-70 to 450 °C
Sensor with shortened adapter	$L_n \text{ min} = 65 \text{ mm}$	-70 to 250 °C

The upper limit of the range of measurement is limited by resistance of the material of the applied thermowell.

If it is ensured with a suitable way of installation that the surface temperature of the part of the sensor located in dangerous area does not exceed the temperature of the required temperature class (T1...T6), the upper limit of the range of measurement may be even higher (max. 600°C). For an example of installation, refer to figure 3.

Measuring range of the sensor with converter is established by the range of the selected converter.

#### Design for explosive atmospheres:

**Fixed closure** pursuant to EN 60079-0 and EN 60079-1,

⊕ II 2 G Ex db IIC T1...T6 Gb  
(Meaning of designation - refer to figure 1)

**Dust-tight closure** pursuant to EN 60079-0 ed. 4 and EN 60079-31:

⊕ II 2 D Ex tb IIIC T=T media Db  
(Meaning of designation - refer to figure 1)

#### Intrinsically safe version with converter:

according to built-in converter

**Electric strength** pursuant to EN 61010-1 Article 6.8.3:

500 V eff for measuring insert Ø 6 mm  
 100 V eff for measuring insert Ø 3 mm  
 (only measuring insert without converter or design with insulated converter)

**Electric insulation resistance** pursuant to IEC 751:

min. 100 MΩ, at 15 to 35°C, max. 80 % relative humidity,  
 min 100 V DC

**Power supply of converter:**

DC 24 V from source SELV, e.g. INAP 16 and INAP 901

**Other data of converter:** refer to the enclosed manual**Display:** LED display to loop 4-20mA

other date refer to enclosed manual

**Ingress Protection** pursuant to EN 60529:

IP 68, 1 m, 30 min

**Operation position:**

discretionary; the gland shall not be situated upwards

**Type of operation:** continuous**Sensor weight:**

with adapter 135 mm 0.93 kg

**Applied materials:**

Stem tube of measuring insert	steel 1.4541
Adapter	steel 1.4541
Head	aluminium alloy painted with blue epoxy colour
	steel 1.4401
Internal wiring	Cu
Head terminals of the terminal board	brass with Ni surface
Connecting elements of the sensor	stainless steel

**OPERATION CONDITIONS**

The environment is defined by the group of parameters and their severity grades IE 36 pursuant to EN 60721-3-3 and the following operation conditions.

**Ambient temperature for head and gland of the sensor:**

- for design without converter  $-50\text{ °C} \leq T_a \leq 85\text{ °C}$
- for design with converter pursuant to the type of converter (refer to the enclosed converter manual) max.  $-50\text{ °C} \leq T_a \leq 75\text{ °C}$
- for design with converter and display pursuant to the type of converter and display (refer to the enclosed converter and display manual) max  $-50\text{ °C} \leq T_a \leq 75\text{ °C}$

**Maximum surface temperature of the sensor:**

it corresponds to with maximum temperature of the measured medium

**Maximum surface temperatures** for equipment operating in the environment with a threat of explosion of gases, steam and mist pursuant to EN 60079-0 ed. 2 and temperature class of the sensor are determined in dependency on the temperature of measured medium pursuant to the following table:

Temperature class	Maximum surface temperature	Maximum temperature of measured medium
T6	85°C	80°C
T5	100°C	95°C
T4	135°C	130°C
T3	200°C	195°C
T2	300°C	290°C
T1	450°C	440°C

**Maximum permitted surface temperature** for the equipment operating in the environment with a threat of explosion of dust pursuant to EN 60079-0:

- Temperature limitation due to occurrence of stirred dust:  
 $T_{\max} = 2/3 T_{cl}$   
 where  $T_{cl}$  is the temperature of ignition of stirred dust
- Temperature limitation due to occurrence of layers of dust to 5 mm thickness:  $T_{\max} = T_{5\text{ mm}} - 75\text{ °C}$   
 where  $T_{5\text{ mm}}$  is the temperature of ignition of dust layer 5 mm thick
- Dust layers over 5 mm – refer to EN 60079-14

**Maximum permitted surface temperature is defined by the lower value of the values specified above.**

**WARNING**

The user shall guarantee that the maximum surface temperature of any part of the sensor does not exceed the temperatures of ignition of any gas, steam or dust, which can occur, due to external thermal effects

**Relative ambient humidity:**

- 10 to 100 % with condensation, with upper limit of water content 29 g H<sub>2</sub>O/kg of dry air
- for converter version according to converter type (see enclosed converter instructions)
- for converter and display version according to converter and display type (see enclosed converter and display instructions)

**Atmospheric pressure:**

70 to 106 kPa

**Vibrations:**

Sensor	with converter		without converter	
	110, 140, 170	200, 260	110, 140, 170	200, 260
Nominal length L [mm]				
Frequency range [Hz]	10 to 500			
Drift amplitude [mm]	0.2	0.15	0.5	0.2
Acceleration amplitude [ms <sup>-2</sup> ]	29.4	19.6	68.7	39.2

**Maximum speed of flow of liquids:**

pursuant to parameters of thermowell used by the customer

**METROLOGICAL DATA**

**Sensing probe:** measuring resistor Pt 100 in connection pursuant to the scheme and table of designs,  $\alpha = 0.00385$  [K<sup>-1</sup>], tolerance class A or B pursuant to IEC 751

**Range of pair temperature differences** pursuant to EN 1434:  
 3 to 180 K

**Internal wiring resistance** at 20 °C: 0.1 Ω/m

Calculated resistance value of internal wiring of the design without converter is specified on the label of the measuring insert.

**Maximum current load of measuring resistor:**

Pt 100 3 mA  
 Pt 500 1 mA

**Recommended measuring current:**

Pt 100 1 mA  
 Pt 500 0,5 mA

**Output signal of the converter** (linear with measured temperature):

4 to 20 mA (+ digital for HART protocol)

**Calibration depth of immersion of the measuring insert of the sensor**

for temperature points within the range from -70 to 250°C:  
 200 mm (min. 160 mm)

for temperature points above 250°C:  
 300 mm (min. 260 mm)

The distance of flange of the measuring insert from the level of medium in the calibration bath shall be at least 40 mm at temperatures to 250°C and min. 70 mm at temperatures above 250°C.

**Temperature response time** pursuant to IEC 751 in whirling water for measuring insert Ø 6 mm (characteristic value):

Without thermowell (separate measuring insert)

$\tau_{0.5}$  6 s

With thermowells pursuant to DIN 43772, shape 4

(L = 100, 140))  $\tau_{0.5}$  85 s

$\tau_{0.9}$  250 s

With thermowells pursuant to DIN 43772, shape 4

(L = 200, 260))  $\tau_{0.5}$  53 s

$\tau_{0.9}$  115 s

**Temperature response time** pursuant to IEC 751 in whirling water for measuring insert Ø 3 mm (characteristic value):

Without thermowell (separate measuring insert)

$\tau_{0.5}$  1.6 s

$\tau_{0.9}$  3.7 s

**RELIABILITY**

Indicators of reliability in operation conditions and conditions of the environment specified herein

- Mean time of operation between failures 96 000 hours (inf. value)
- Expected service life 10 years

**CALIBRATION**

It is realized pursuant to TPM 3342-94 and in compliance with IEC 751, usually in three temperature points evenly distributed within the operation range of the sensor or in the points according to the requirement of the customer. Calibration sheets with measured data are issued for calibrated sensors.

**DESIGNATION:****Data on head label**

- Trademark of the manufacturer
- Made in Czech Republic
- Type of resistance sensor, nominal value  $R_0$  / tolerance class / configuration of wires of internal wiring \*)
- Measuring range or set-up converter range
- Product ordering number
- Ingress Protection
- Serial number
- Output signal 4 to 20 mA (design with converter)
- Ambient temperature
- Mark of non-explosiveness:
  - ⊕ II 2 G Ex db IIC T1...T6 Gb
  - ⊕ II 2 D Ex tb IIIC T=T media Db
- and number of the EU-Type Examination Certificate
- Designation of non-explosiveness and number of the EU-Type Examination Certificate (for design with converter Ex ia)
- Mark CE 1026
- Other data for design with proof of metrological compliance (/M5)
  - o the conformity marking (CE + supplementary metrology marking) and the number of the notified person
  - o EU type examination certificate number TCM 321/12 - 4906
  - o range of temperature difference
  - o serial number /1 a /2 for unambiguous resolution of sensors for inlet and return pipes
- other data for design /M1, /M2, /M3 a /M4
- Evaluation certificate. No ZR 141/10-
- \*) Configuration of wires of internal wiring is not specified for the converter

**Data on label of measuring insert**

- Trade mark
- Sensor type, nominal value  $R_0$  / tolerance class / Configuration of wires of internal wiring \*)
- Serial number
- Resistance value of internal wiring (for design without converter)

\*) Configuration of wires of internal wiring is not specified for the converter

**Data on converter label**

- Trade mark
- Sensor type
- Pre-set temperature range
- Designation of non-explosiveness and number of the EU-Type Examination Certificate
- the conformity marking CE (for converter Ex ia with the number of the notified person)

**Data on display**

- Trade mark
- the conformity marking CE

**DELIVERY**

Unless agreed otherwise with the customer, each delivery includes

- Delivery note
- Sensor pursuant to the purchase order
- Sealing ring
  - o Cu 18 x 22 x1.5 (ČSN 02 9310.2) for connecting thread M18 x 1.5
  - o 21x27 TPD 62-014-91 for connecting thread M20 x 1.5, G 1/2
  - o 14x20x2 TPD 62-014-91 for connecting thread M20 x 1.5, G 1/2
- (Sealing ring is not delivered for the thread 1/2-14NPT)
- Allen key 1,5 mm
- Suitable thermowells and nipples ordered separately pursuant to the catalogue of accessories, type 991
- Suitable cable gland; it shall be ordered separately pursuant to the catalogue of accessories, type 991. An instruction sheet is delivered with each cable gland
- Optional accessories to the sensor with programmable converter
  - o Configuration (parameterization) programme pursuant to the required converter
  - o Communication modem (for serial port RS 232C) pursuant to the required converter

- Accompanying technical documentation in Czech
  - o Product manual
  - o Product quality and completeness certificate, which also serves as the warranty certificate
  - o EU Declaration of Conformity
  - o EU Declaration of Conformity for Conformity with Metrological Compliance (/ M5)

If it is established in the purchase contract or agreed otherwise, the following documentation can be also delivered with the product

- Declaration of Conformity with purchase order 2.1 acc. to EN 10204
- Declaration of Conformity of the supplier pursuant to EN ISO/IEC 17050-1
- Calibration sheet (for uncertified calibrated design)
- Copy of EU-Type Examination Certificate pursuant to the Directive No 2014/34/EU for fixed and dust-tight closure
- Copy of EU-Type Examination Certificate pursuant to the Directive No 2014/34/EU (ATEX) for converter Ex ia
- Copy of Evaluation certificate for design /M1, /M2, /M3 and /M4
- Test report about the seismic and the vibration qualification

**CERTIFICATION**

- Non-explosiveness Ex ia, EU-Type Examination Certificate pursuant to the Directive 2014/34/EU FTZÚ 08 ATEX 0199X with supplementary No. 1 and 2
- Non-explosiveness Ex ia, EU-Type Examination Certificate pursuant to the 2014/34/EU (pursuant to the type of the converter and display)
- Declaration of metrological conformity (MID) in accordance with Module D of Directive No. 2014/32/EU, EU Type Examination Certificate No. TCM 321/12-4906
- Evaluation certificate. No. ZR 114/10-0068

**ASSESSMENT OF CONFORMITY PURSUANT TO THE DIRECTIVE 2014/32 EU**

Couple sensors are verified pursuant to EN 1434-5.

The sensors are rated products pursuant to the Directive 2014/32 EU of the European Parliament and the Council and EU Declaration of Conformity is issued for them.

The manufacturer performs subsequent verification under EN 1434-5. Subsequent verification is ordered in the department AMS ZPA N. Paka a.s. (ams@zpanp.cz).

For subsequent verification, send the whole couple tied together.

**METHOD OF PLACING THE MARK OF ASSEMBLY AND SERVICE ORGANIZATION AND REINSURANCE MARKS**

Verified sensors have a self-adhesive label with reinsurance mark. The label is stuck on the terminal board and the sensor head.

After installation on place of use the sensors will be reassured with mounting seal eventually with label, preventing unauthorized manipulation.

After subsequent verification, the sensors will be provided with a self-adhesive label with an official mark. The label will be stuck on the terminal board and the sensor head instead of the original reinsurance mark.

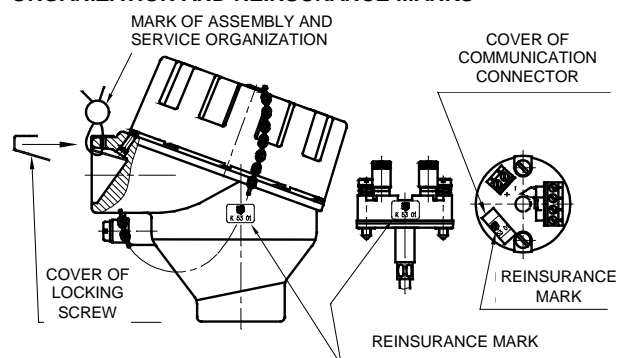
**PLACING THE MARK OF ASSEMBLY AND SERVICE ORGANIZATION AND REINSURANCE MARKS****PACKING**

Both sensors and accessories are delivered in a packing ensuring resistance to the impact of thermal effects and mechanical effects pursuant to controlled packing regulations.

**TRANSPORT**

The sensors may be transported on conditions corresponding to the set of combinations of classes IE 21 pursuant to EN 60721-3-2 (i.e. by airplanes and trucks, in premises that are ventilated and protected against atmospheric conditions).

**STORAGE**

The products may be stored on conditions corresponding to the set of combinations of classes IE 12 pursuant to EN 60721-3-1 (but with ambient temperature from -20 to 70 °C (i.e. in places without regulation of temperature and humidity, with a threat of occurrence of condensation, dripping water and formation of ice, without a special threat of an attack with biological agents, with vibrations of small significance and not situated close to sources of dust and sand).

**ORDERING TEMPERATURE SENSORS**

The purchase order shall specify

- Name
- Product ordering number
- Additional requirements for sensor design pursuant to Table 2
- Request for other documentation pursuant to Table 2
- Measuring range
- If calibration is required and in what temperature points
- If the delivery of thermowell and nipple pursuant to the type 991 is required for the sensor as accessories
- If the delivery of gland for output cable pursuant to the type 991 is required for the sensor as accessories
- If optional accessories to the sensor with programmable converter is required
- Other (special) requirements
- Number of pieces

Behind the ordering number specified pursuant to the above mentioned table, the customer shall identify the required range of measured temperature (i.e. lower and upper temperature limits in °C) and, as the case may be, other non-standard required parameters for converter configuration (e.g. indication of sensor tripping, dampening, required designation - tagging etc.).

**PURCHASE ORDER EXAMPLE****Standard design:**

Resistance sensor temperature Ex d (Ex t) to thermowell  
DIN without converter  
233 410 111 1B/J4/Q1  
Calibration points of 100, 250 and 400 ° C  
Range -70 to 450°C  
6 pcs

**Special request:**

Resistance sensor temperature Ex d (Ex t) to thermowell  
DIN with converter  
233 910 211 1B/18/2.1  
Nominal length L 380 mm  
Range 0 to 100°C  
6 pcs

**ORDERING ACCESSORIES**

The purchase order shall specify:

- Name
- Product ordering number
- Number of pieces

**PURCHASE ORDER EXAMPLE****Standard design:**

1. Welding thermowell pursuant to DIN, shape 4  
991 DIN 407244  
20 pcs
2. Direct nipple for welding thermowell shape 4  
991 NVD4 D24  
20 pcs
3. Cable gland  
991 VM 612  
5 pcs

**Special request:**

Nipple  
991 NVD4 D24 99  
material 1.5415  
6 pcs

TABLE 1 - DESIGN OF TEMPERATURE SENSORS Ex d (Ex t) TO THERMOWELL TYPE 233

SPECIFICATION						ORDERING NUMBER																					
						233	x	x	0	x	x	1	x	x	/xxxxxx	/xxx											
Nominal length L [mm]	110	Length of adapter L <sub>n</sub> [mm]	125	Length of measuring insert L <sub>mv</sub> [mm]	275	1																					
	140		135		315	2																					
	170		125		335	3																					
	200		135		375	4																					
	260				435	5																					
	410				585	6																					
	Other (min. 75) *)						9																				
Nominal length L [mm]	110	Length of adapter L <sub>n</sub> [mm]	65	Length of measuring insert L <sub>mv</sub> [mm]	215	1																					
	140				245	2																					
	170				275	3																					
	200				305	4																					
	260				365	5																					
	410				515	6																					
	Other (min. 75) *)								9																		
Length of adapter [mm]	135 (125)					1																					
	65 max. measuring range [°C] -70 to 250					2																					
Other *) **) (min. 65)					9																						
Thermowell material				without thermowell					0																		
Connecting thread	M18 x 1.5	ø tube of measuring insert	6 ± 0,1				1																				
	M20 x 1.5							2		1																	
	G1/2							3																			
	M14 x 1,5				3 ± 0,1			4		3																	
	1/2-14NPT				6 ± 0,1			5		1																	
	Other *)							9																			
Head of the sensor with thread for gland Ex d (Ex t) - overview of glands see Tab.8,9	Aluminium alloy painted with blue epoxy colour			M20x1.5							1																
				1/2-14NPT							2																
	Corrosion resistant steel 1.4401			M20x1.5							3																
				1/2-14NPT							4																
Tube of measuring insert [mm]	Ø6 ± 0,1																										
	Ø3 ± 0,1 (only with connecting thread M14 x 1,5)										4			3													
Measuring resistor (sensing probe)	Pt100																					1					
	Pt 500																					2					
	Other *)																					9					
Tolerance class	A guaranteed only within range to 300°C																					A					
	B																					B					
Connection of terminal board	Single - four-wire (1xPt/ /4)																					/J4					
	Double - two-wire (2xPt/B/2)		with measuring insert ø 3 *)																			B /D2					
	Double - three-wire (2xPt/ 3)																					/D3					
Converter (connection for converter: single, double, three or four-wire, pursuant to the converter)	Converter type		Galvanic separation	Ex ia	Range [°C]																						
	Analogue	INPAL 420			-50 to 50																		/07				
					-30 to 70																			/55			
					0 to 50																				/15		
					0 to 100																					/18	
					0 to 150																					/19	
					0 to 200																					/20	
					0 to 250																					/21	
	0 to 400				1																	/23					
	Programmable	TH 100				Adjustable range																		/HRF			
						APAQ-HRF																			/HRFX		
						TH 100-ex																				/TH100	
						TH 200																					/TH200
						TH 200-ex																					/TH200X
						IPAQ-H																					/IPAQH
						IPAQ-HX																					/IPAQHx
	HART protocol	MINIPAQ-HLP				Programmable range																		/MINIPAQ			
						IPAQ C330																			/C300		
						IPAQ C330X																				/C300X	
						TH 300																					/TH300
						TH 300-ex																					/TH300X
						MESO-H																					/MESOH
						MESO-HX																					/MESOHx
Other *)																							/99				
					Without converter (for installation of the converter by the customer)																					/00	
					LED display to loop 4-20 mA (not possible with head from corrosion resistant steel) (only with converter INPAL 420, APAQ-HRF, TH 100, MINIPAQ-HLP)																						/LD
					LPI-02																						

**Standard design**

\*) Only as a special requirement after an agreement with the manufacturer

\*\*) In case of adapter length below 125 mm (minimum 65 mm), the temperature range is decreased to -70 to 250 °C.

**TABLE 2 – ADDITIONAL REQUIREMENT FOR DESIGN OF TEMPERATURE SENSORS ex d (Ex t) TO THERMOWELL, TYPE 233**

SPECIFICATIONS				CODE	
PROOF OF METROLOGICAL COMPLIANCE	DESIGN OF TEMPERATURE SENSORS	MEASURING RANGE [°C]	USE		
Proof of metrological compliance pursuant to Directive No. 2014/32/EU (MID), Annex MI-004 *)	couple sensors without converter in connection 1xPt100/..1/4 min. length of measuring insert Ø 6 mm = 210 mm min. immersion = 160 mm	0 to 180	application for residential and business premises and for the light industry	/M5	
CALIBRATION (for sensors as described below)	DESIGN OF TEMPERATURE SENSORS	MEASURING RANGE [°C]	USE		
Calibration by TPM 3342-94, in three calibration points evenly distributed in the sensor measuring range for use as part of the customer's measurement assemblies pursuant to Directive No. 2014/32/EU (MID), Annex MI-002 and MI-005 **)	sensors without converter in connection 1xPt100/..1/4 min. length of measuring insert for temperature to 250°C Ø 6 mm = 210 mm for temperature over 250°C Ø 6 mm = 275 mm	-50 to 50	application for residential and business premises and for the light industry	/M1	
		-50 to 100		/M2	
		0 to 200		/M3	
		0 to 250 for sensors with extension lengths shorter than 125 mm (min. 65 mm)		/M4	
		0 to 300 for sensor with measuring resistance in tolerance class A			
0 to 400 for sensors with extension lengths 125 mm and longer, with measuring resistance in tolerance class B					
CALIBRATION	NUMBER OF CALIBRATION POINTS	CALIBRATION RANGE			
Calibration by TPM 3342-94, define calibration points	3	0 to 420 °C	/Q1		
	3	0 to 600 °C	/Q2		
	3	-50 to 600 °C	/Q22		
	Other	-50 to 600 °C	/Q9		
REQUIREMENT FOR OTHER DOCUMENTATION			USE		
Copy of EU-Type Examination Certificate (pursuant to Directive No. 2014/32/EU)			M5	/MID	
Copy of Evaluation certificate No. ZR 141/10-0068			M1, M2, M3, and M4	/EC	
EU Declaration of Conformity			for design with converter	/EU	
Copy of EU-Type Examination Certificate acc to the 2014/34/EU			for fixed closure and a dust-tight closure	/Exd	
Copy of EU-Type Examination Certificate acc to the 2014/34/EU			for converter and display Ex ia	/Exi	
Declaration of Conformity with purchase order 2.1 pursuant to EN 10204				/2.1	

Specify the code behind ordering number. Define calibration points for codes Q4, Q42 a Q9.

- \*) **WARNING - This request can only be selected with measuring insert Ø6 ± 0,1.**
- \*\*) only as a special request after an agreement with the manufacturer

**TABLE 3 – OVERVIEW OF DESIGNS AND ORDERING OF WELDING THERMOWELLS PURSUANT TO DIN, SHAPE 4 (4F)**

SPECIFICATIONS						ORDERING NUMBER														
						991	DIN	x	x	x	x	x	x	x						
Cone welding thermowell	Shape 4	pursuant to DIN 43772	Without flange		PN 250			4	0											
	Shape 4F		With flange **)					4	F											
	Internal bore [mm]		Ø 3,5								3									
			Ø 7								7									
	Internal thread	M14x1,5	Internal Ø of thermowell	18	Internal bore [mm]	Ø 3,5						3	1							
		M18x1.5		24										2						
		M20x1.5		26			Internal bore [mm]	Ø 7							3					
		G 1/2															4			
		1/2 – 14 NPT																5		
	Nominal length of thermowell L [mm]	110	L1 [mm]	65	L2 [mm]	105										1				
		140		65		135										2				
		170		133		165									3					
		200		65		195										4				
		200		125		195											5			
		260		125		255												6		
		410		275		405													7	
		Other (max. 1200) *)																		9
	Material of thermowell	1.7335 ***)	Maximum operation temperature [°C]	550												1				
		1.7380 ***)		580													2			
		1.4541 ****)		580														3		
1.4571 ****)		400																4		
1.5415 *) ****)		530																5		
1.4903 *) ****)		620																	6	
A105, C22.8 or 1.0460 (P250GH) *) ****)		425																	7	
1.4404 *) ****)		550																		8
Other *)																			9	

- \*) Upon a special request after an agreement with the manufacturer
- \*\*) Flange design (shape, PN, DN and material) pursuant to the requirement of the customer
- \*\*\*) Thermowells of these materials cannot be used for zone 0
- \*\*\*\*) Surface treatment of thermowells: preservation with grease - oil
- \*\*\*\*\*) For zone 0, thermowell from corrosion resistant steel shall be used (pursuant to (pursuant to EN 60079-26)
- \*\*\*\*\*) thermowells of these materials are suitable for contact with food



**TABLE 4 – ACCESSORIES - OVERVIEW OF DESIGNS RECOMMENDED SCREW-IN THERMOWELLS SHAPE 6 PURSUANT TO DIN 43772, TYPE 991 (order separately)**

SPECIFICATION				ORDERING NUMBER								
				991	DIN	6	x	x	x	x	x	
Cone screw-in thermowell	thermowell pursuant to DIN 43772		PN 250			6						
	external thread		G1/2				1					
			G1				2					
			M27x2				3					
			G3/4				4					
			M20x1.5				6					
	internal bore [mm]		Ø 7					7				
	internal thread		M18x1.5						2			
			M20x1.5/						3			
			G 1/2/						4			
	Nominal length of thermowell L [mm]	L1 [mm]	110									1
			140									2
			170									3
			200									4
			260									6
410											7	
other (maximum 1200) *											9	
Material of thermowell			1.4541 ***	maximum operation temperature [°C]	580							
	1.4571 ***	400									4	
	other *) **										9	

\*) upon a special requirement after an agreement with the manufacturer  
 \*\*) For zone 0, thermowell from corrosion resistant steel shall be used (pursuant to (pursuant to EN 60079-26)  
 \*\*\*) thermowells of these materials are suitable for contact with food

**TABLE 5 – ACCESSORIES - OVERVIEW OF DESIGNS RECOMMENDED SCREW-IN THERMOWELLS SHAPE 7 PURSUANT TO DIN 43772, TYPE 991 (order separately)**

SPECIFICATION				ORDERING NUMBER								
				991	DIN	K	x	x	x	x	x	
Cone screw-in thermowell	Shape 7 pursuant to DIN 43772		PN 250			K						
	Internal bore [mm]		Ø 7				7					
	External fixing thread		½ - 14 NPT					5				
			¾ - 14 NPT					7				
			1 - 11,5 NPT						8			
			other *)						9			
	Internal thread for sensor		M18 x1.5						2			
			½ - 14 NPT						5			
			other *)							9		
	Nominal length of thermowell L [mm]	L1 [mm]	110									1
			140									2
			170									3
			200									4
			260 *)									6
			410 *)									7
Other (maximum 1200) *)											9	
Material of thermowell			1.7335 *) **	maximum operation temperature [°C]	550							
	1.7380 *) **	580								2		
	1.4541 ****)	580									3	
	1.4571 ****)	400									4	
	1.5415 *) **	530									5	
	1.4903 *) ****)	620									6	
	A105, C22.8 or 1.0460 (P250GH) *) **)	425									7	
	1.4404 *) ****)	550									8	
	Other *) **)										9	

\*) upon a special requirement after an agreement with the manufacturer  
 \*\*) surface treatment of thermowells: preservation with grease – oil  
 \*\*\*) For zone 0, thermowell from corrosion resistant steel shall be used (pursuant to (pursuant to EN 60079-26)  
 \*\*\*\*) thermowells of these materials are suitable for contact with food

**TABLE 6 – ACCESSORIES - OVERVIEW OF DESIGNS RECOMMENDED NIPPLES FOR WELDING THERMOWELLS, TYPE 991 (order separately)**

SPECIFICATION				ORDERING NUMBER				
				991	xxx	x	xxx	xx
Nipple pursuant to DIN 43772 for welding thermowell shape 4 pursuant to DIN 43772	Direct nipple							
	Internal bore [mm]	Ø 24	PN	250				
		Ø 26						
	Material	15 128.5 **)	maximum operation temperature [°C]	550				51
		1.4541		550				72
		1.5415 *) **)		530				50
		1.4903 *)		620				71
		A105, C22.8 or 1.0460 (P250GH) *) **)		425				20
		1.4404 *)		550				73
		Other *)						99

\*) upon a special requirement after an agreement with the manufacturer  
 \*\*) surface treatment of thermowells: preservation with grease – oil

**TABLE 7 – ACCESSORIES - OVERVIEW OF DESIGNS RECOMMENDED NIPPLES FOR SCREW-IN THERMOWELLS, TYPE 991 (order separately)**

SPECIFICATION						ORDERING NUMBER						
						991	xxx	x	xxx	xx		
Nipple for screw-in thermowells pursuant to DIN 43772 shape 6 a 7	Direct nipple						NVP					
	Oblique (chamfer 45°)						NVS					
	Internal bore	M20x1,5 G 1/2	for embed sealing ring	PN	40			1	M20			
									G12			
		M20x1,5 G 1/2	without embed for sealing ring				160			2	M20	
											G12	
		M27x2 G 3/4 3/4 – 14 NPT G1 Other *)							4	M27		
										G34		
										N34		
										G01		
	Material	1.0308 or 1.0122 1.0577 15 128.5 1.4541 Other *)	surface treatment	preservation with grease – oil	maximum operation temperature [°C]	300 (only PN 40) 400 550 550 pursuant to material			M20	13		
									G12			
									M27			
									G34			
									N34			
								G01	15			
								M27	51			
								G34				
								N34				
									72			
									99			

\*) upon a special requirement after an agreement with the manufacturer

**TABLE 8 - OVERVIEW OF DESIGNS AND ORDERING OF CABLE GLANDS Ex d (Ex t) BRASS – TYPE 991**

SPECIFICATION								Ordering number			
								991	xx	xxx	
Gland Ex d (Ex t) brass		Cable clamp (clamping module)				Thread	Torque of gland body	For cable Ø [mm]			
Size	Wrench		Size	Dimension							
	A	B		C	Ds						
No. 4	OK 17	OK 24	No. 4	5	20	M20x1.5	30 - 35 Nm	4,5-8.5		VM	458
No. 5	OK 19		No. 5	5	22						
No. 6	OK 24		No. 6	6	27.5						
No. 4	OK 17		1/2-14 NPT	No. 4	5	20	25 - 30 Nm	4,5-8.5		VK	458
No. 5	OK 19			No. 5	5	22					
No. 6	OK 24			No. 6	6	27.5					

**TABLE 9 - OVERVIEW OF DESIGNS AND ORDERING OF CABLE GLANDS Ex d (Ex t) BRASS – TYPE 991**

These glands will be delivered until stocks sell out

SPECIFICATION								Ordering number			
								991	xx	xxx	
Gland Ex d (Ex t) brass		Cable clamp (clamping module)				Thread	Torque of gland body	For cable Ø [mm]			
Size	Wrench		Size	Dimension							
	A	B		C	Ds						
No. 5	OK 19	OK 24	No. 5	5	22	1/2-14 NPT	25 - 30 Nm	6-12		VM	612

**TABLE 10 –OVERVIEW OF SEALING RINGS TYPE 991 SUPPLIED TO TEMPERATURE SENSORS**

EXTERNAL FIXING THREAD OF TEMPERATURE SENSORS	SEALING RING			
	DIMENSION [mm] Ød x ØD x t	MATERIAL	NUMBER	ORDERING NUMBER
M14 x 1,5	14x20x2	copper thermally insulating insert	1 Pcs	991 TK 14
M18 x 1,5	18x22x1,5	copper		991 TK 18
M20 x 1,5 G1/2	21x27x2	copper thermally insulating insert		991 TK 21
1/2-14NPT	-	-	-	-

The sealing ring is supplied to each sensor by default, only for the sensor with internal thread 1/2-14NPT the sealing ring is not supplied. The sealing ring can also be ordered separately using ordering number

**INSTALLATION AND CONNECTION**

**SENSOR INSTALLATION**

Install the sensors by screwing into the relevant thermowell screwed into the nipple on the piping (technological equipment) or welded into the piping wall. Before the installation, put on the enclosed sealing ring in advance (for thread 1/2-14NPT, the sealing ring is not used). During the installation, torque of 70 Nm is recommended, for thread 1/2-14NPT 40 Nm.

With respect to maintaining metrological properties and the longest possible service life, it is not recommended to install the sensors in places with high turbulence of the medium, which is caused e.g. by a rapid transition from a small diameter of the piping to a larger one (when failing to comply with the required shape and dimensions of diffuser behind the flow meter), etc. Recommended distance of the temperature sensor from the installation flange of the flow meter is min. 1 m.



**WARNING**

The temperature sensor may be installed to the thermowell located in the zone 0 (20), zone 1 (1) or zone 2 (22), **thermowell for zone 0 must be in accordance with the EN 60079-26.** (See figure 2).

The other parts of the sensor (fitting, adapter, connecting head) may be located in zone 1 (21) or zone 2 (22).

**When installing sensor in the thermowell located in zone 20, a pre-fuse with the following parameters must be used in the converter encoder circuit: Ceramic, quick break (F), short circuit resistance 1500A (H), e.g. ceramic tube fuse Ø5 x 20 mm, F100mA.**

**Distance of the fixed closure Ex d IIC from close structures or between the closures shall be at least 40 mm.**

**The temperature sensor with a paint finish must be installed in an explosive atmosphere with dust so as to avoid the occurrence of creep discharges**

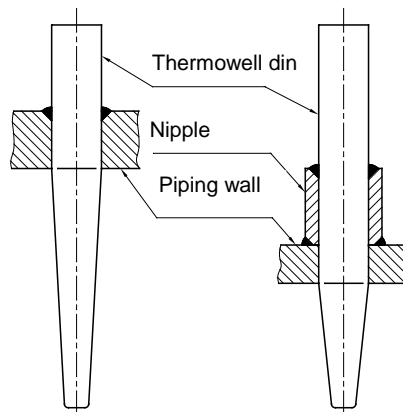
**EXAMPLES OF INSTALLATION OF THERMOWELLS DIN****CABLE GLANDS INSTALLATION**

Only a certified cable gland shall be used to secure the fixed closure (dust-tight closure) Ex d IIC (Ex tb IIC) with IP 68 protection (see accessories type 991 or another similar gland). For temperature sensors with converter, a barrier cable gland must be used in zone 1 of the IIC gas gauge, or an Ex ia converter.

The gland shall be tightened in the sensor head in the prescribed way.

Torque of gland body:

- for gland with thread 1/2 - 14NPT 25 – 30Nm
- for gland with thread M20x1.530 – 35Nm

Installation of the cable in the gland, its sealing and securing against pull-out shall be realized pursuant to the instruction sheet of the gland supplier.

**WARNING**

**Do not use other sealing rings in the gland than the original ones delivered by the manufacturer. Do not change artificially the outer diameter of the cable e.g. by winding it around with electrical insulating tapes.**

**ELECTRICAL CONNECTION**

The electrical connection may be only realized by qualified workers.

**The sensor installation in conditions with explosive gaseous atmosphere or flammable dust shall comply with the requirements of EN 60079-14.**

The terminal board of the sensor (converter) is accessible after the unscrewing of the lid of the head.

Connect the evaluation devices to the sensor with a non-armoured cable with double insulation (internal wires with Cu core with cross-section 0.5 to 1.5 mm<sup>2</sup>).

Seal the cable in the gland by prescribed tightening of the closing nut pursuant to instruction sheet of the gland. Then secure it with clamp against pull-out.

**WARNING**

**The connecting cable must have a casing of thermoplastic, thermoset or elastomeric materials. The cable must be circular and compact, the filler or shell must be extruded and the filler material, if used, must be**

**non-absorbent. The length of the connecting cable must be at least min. 3 m. Temperature resistance of the cable shall comply with the ambient temperature!**

The cable insulation shall have chemical and mechanical resistances in compliance with the conditions, in which the cable will be installed. It is recommended supporting the cable along its length between the sensor and the follow-up device. In the environment with interfering signals, use a shielded cable in the power supply circuit. Shielding may be only grounded (earthed) in one point. The cable should not be placed together with power cables.

In case of the sensor with HART protocol converter, the maximum length of wiring is defined by the arrangement of wires of the connecting cable. The total length of wiring may be up to 1500 m. It requires a twisted two-wire with shared shielding with the cross section of the core min. 0.5 mm<sup>2</sup>. The HART communicator is connected to the supply loop of the sensor with converter pursuant to Figure 5. To ensure reliable commutation, there shall be total load resistance of min. 250 Ω in the circuit of the output loop.

**WARNING**

**Programmable converter may not be connected to a computer or a HART communicator, if the converter is located in explosive environment.**

The surface temperature of the converter must not exceed the maximum surface temperature for a given temperature class.

For installation in a dangerous area, a connection is required (placing on the same potential). You can use the terminals on the sensor head to do this.

The sensor need not be connected separately to the interconnection system if it is firmly attached and metallically connected to the components or piping that is connected to the interconnection system.

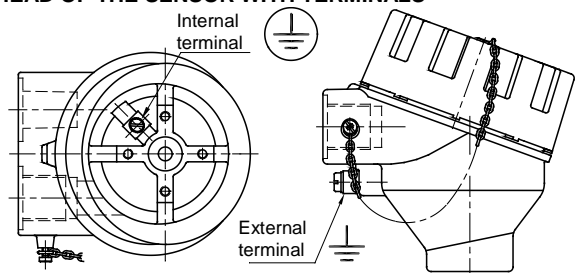
**HEAD OF THE SENSOR WITH TERMINALS****Maximum cross-section of wire for connection to external and internal terminals:**

Internal terminal: stranded wire 1.5 mm<sup>2</sup>, full wire 2.5 mm<sup>2</sup>

External terminal: stranded wire 4.0 mm<sup>2</sup>, full wire 6.0 mm<sup>2</sup>

If stranded wires are used for the interconnection, they shall be protected against fraying with pressing hollow.

**CLOSING HEAD OF FIXED CLOSURE Ex d**

After electrical connection of the sensor, the lid of the head shall be fully tightened by hand, then released slightly to ensure matching with the closest groove against the securing pin and fixed with this screw against releasing. If the lid of the sensor is not tightened and secured by the above mentioned screw, the sensor does not comply with the requirements of fixed closure Ex d.

**WARNING:**

**Power supply of the sensor may not be connected before closing the fixed closure!**

**SENSOR INSTALLATION WITHOUT CONVERTER AND SENSOR WITH CONVERTER Ex ia TO ZONE 0 (20)****WARNING:**

**The user is responsible for ensuring that during operation in zone 0 is between the sensor head from an aluminium alloy and other equipment preclude any risk of ignition due to impact and friction.**

The sensor without converter can be used, in case of the installation pursuant to EN 60079-11, Art. 5.7 in the intrinsically safe circuit Ex ia according to EN 60079-25), as a simple equipment. For simple equipment, the maximum temperature can be determined from the value of the PO of the follower and the temperature class is determined.

**Sensor with converter Ex ia** can be used while adhering to the Ex ia parameters of the converter shall be complied with pursuant to the enclosed converter manual.

In intrinsically safe circuits, only insulated cables that are capable of withstanding an electrical strength test with a voltage equal to twice the voltage in the intrinsically safe circuit or 500 V eff (DC 750 V) must be used, with a larger value being taken.

When installing intrinsically safe circuits, including cables, do not exceed the maximum allowable inductance, capacity or ratio LiR and surface temperature. Permissible values are determined from the documentation of the connecting device or label. Place follow-up equipment out of the danger area. An intrinsically safe source approved for supplying intrinsically safe devices in accordance with EN 60079-11 must always be used.

The shield of the intrinsically safe circuit cable must be grounded in the same place as the intrinsically safe circuit, the connection must be outside the dangerous area. If the intrinsically safe circuit is isolated from the ground, the shield must be connected in one place to the protective interconnection system. This can be using the terminals on the sensor head.

**COMMISSIONING**

After the sensor installation, including the fixed closure, and connection of the follow-up (evaluation) device to the supply voltage (and the settlement period of the converter), the equipment is prepared for operation.



**WARNING**

**After installation must be require initial inspection equipment and installations according to EN 60079-17**



**OPERATION AND MAINTENANCE**

The sensor does not require any operation; maintenance and follow-up regular periodic revision or permanent supervision of expert staff are performed pursuant to EN 60079-17



**WARNING**

**Any intervention into the sensor and its structure will result in a change of properties and can result in an explosion!**



**SENSOR UNINSTALLATION**



**WARNING**

**The temperature sensor is in design Ex and must be disconnected from the power supply source before opening the lid of the head and releasing the gland in the explosive environment!**



Then release the securing screw of the lid by ALLEN key 1.5 mm (a part of accessories). The terminal board of the sensor (converter) is accessible after unscrewing the lid of the head. The measuring insert of the sensor can be replaced and is removed from the head after disconnecting the cable by releasing two screws.

Before a complete uninstallation of the sensor, the wire for mutual interconnection shall be released from the external terminal or the internal terminal on the head of the sensor. Disconnect the connecting cable from the terminal board, then release it from the clamp on the gland and from closing nut of the gland. Unscrew the sensor from the thermowell; torque for releasing is approx. 70 Nm for thread M18 x 1,5, G1/2 a M20 x 1,5, approx. 50 Nm for thread M14 x 1,5 and approx.40 Nm for thread 1/2-14NPT. While releasing the screw joint of the sensor, the thermowell may never be released.

**REPAIRS**

The sensors shall be repaired by the manufacturer. They shall be sent for repair in the original or equal package without accessories.

**SPARE PARTS**

Spare parts shall be delivered by the manufacturer. Relevant measuring inserts can be ordered pursuant to the following table:

SPECIFICATION	ORDERING NUMBER					
	MV230	/xxx/	1	x	x	/xxxx
Length of measuring insert [mm]		pursuant to tab. 1	1			
Ø measuring insert [mm]	6 ± 0,1		1			
	3 ± 0,1		3			
Sensing probe	Pt100			1		
	Pt500			2		
Tolerance class	A				A	
	B				B	
Connection of terminal board or converter	Pt100/ /4					/J4
	2xPt100/B/2					/D2
	2xPt100/ /3					/D3
	Converter pursuant to tab. 1					/converter

**EXAMPLE OF PURCHASE ORDER OF MEASURING INSERT**

Resistor measuring insert without converter  
230 /375/ 11B/J4  
6 pcs

To order the certified measuring inserts, specify the code according to Table 2 – Additional requirements – behind the ordering number.

The measuring inserts are marked according to Article DESIGNATION. Designation is completed with the ordering number.

Each delivery includes

- Delivery note
- Measuring insert pursuant to the purchase order
- Optional accessories to the measuring insert with a programmable converter
  - o Configuration program according to the required converter
  - o Communication modem (for serial port RS 232C) according to the required converter
- Accompanying technical documentation in Czech
  - o Product manual
  - o Product quality and completeness certificate, which also serves as the warranty certificate
  - o EU Declaration of Conformity

If it is established in the purchase contract or agreed otherwise, the following documentation can be also delivered with the product

- Calibration sheet (for calibrated design)
- Declaration of Conformity of the supplier according to EN ISO/IEC 17050-1
- Copy of EU-Type Examination Certificate pursuant to the Directive No 2014/34/EU (ATEX). for design with converter Ex ia

**WARRANTY**

The warranty period is 24 months from the receiving of the product by the customer, unless established otherwise in the contract. Rejection of defects shall be enforced in writing at the manufacturer within the warranty period. The rejecting side shall identify the product name, ordering and manufacturing numbers, date of issue and number of the delivery note, clear description of the occurring defect and the subject of the claim. If the rejecting side is invited to send the device for repair, it shall do so in the original package of the manufacturer and/or in another package ensuring safe transport.

The warranty shall not apply to defects caused by unauthorized intervention into the device, its forced mechanical damage or failure to comply with operation conditions of the product and the product manual.

**DISABLING AND LIQUIDATION**

The product and its package do not include any parts that could impact the environment.

Products that are withdrawn from operation, including their packages (with the exception of products marked as electrical equipment for the purposes of return withdrawal and separate salvage of electrical waste), may be disposed of to sorted or unsorted waste pursuant to the type of waste.

The manufacturer realizes free return withdrawal of marked electrical equipment (from 13.8.2005) from the consumer and points out the danger connected with their illegal disposal. The package of the sensor can be recycled completely. Metal parts of the products are recycled, non-recyclable plastic materials and electrical waste shall be disposed of in accordance with applicable legislation.

FIGURE 1 – MARK OF NON-EXPLOSIVENESS

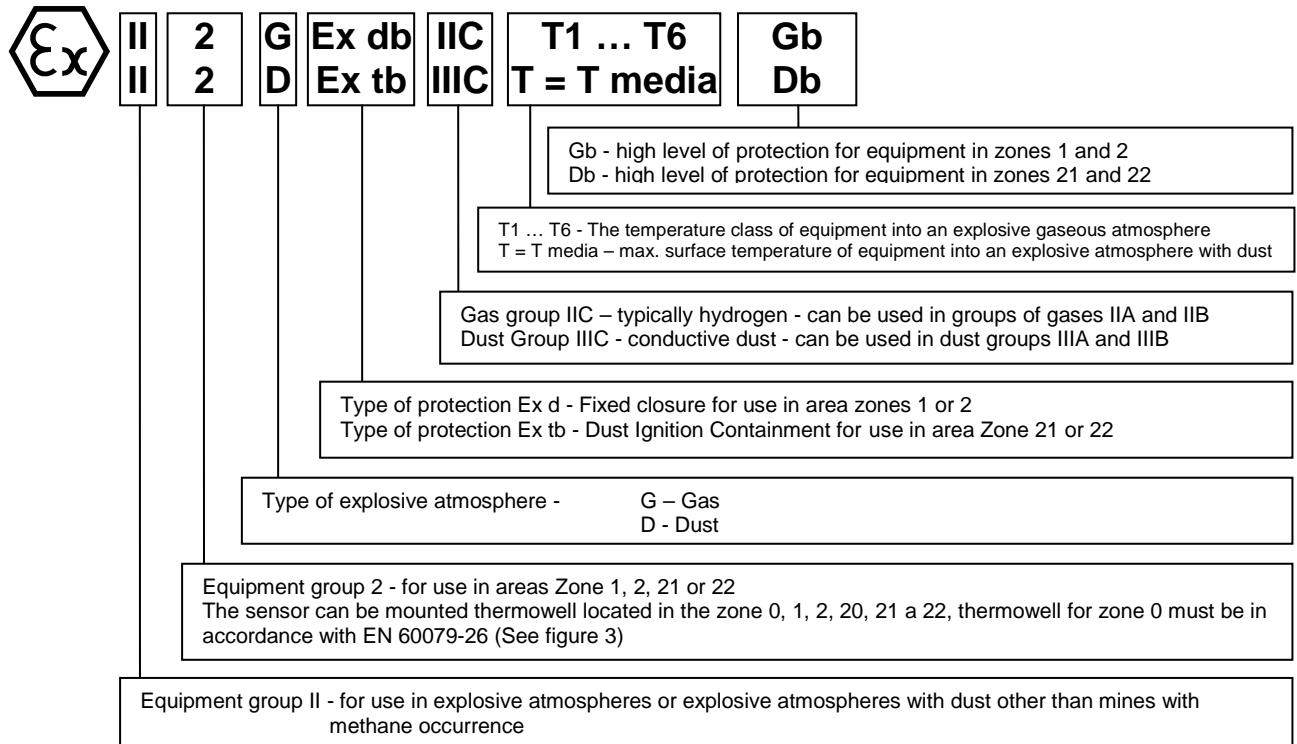

FIGURE 2 – THERMOWELL FOR SENSOR TEMPERATURE Ex d FOR ZONE 0 (pursuant to EN 60079-26)

Thermowell that is used in the function of a partition wall between the zones 1 or 2 and zone 0 shall be made of a corrosion resistant metal and with wall thickness  $t \geq 1$  mm

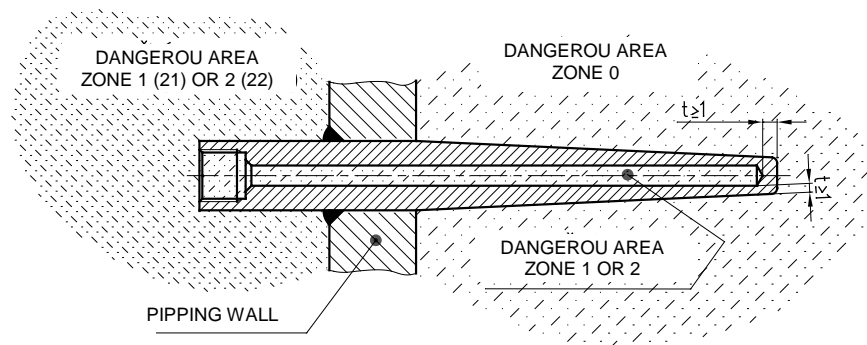
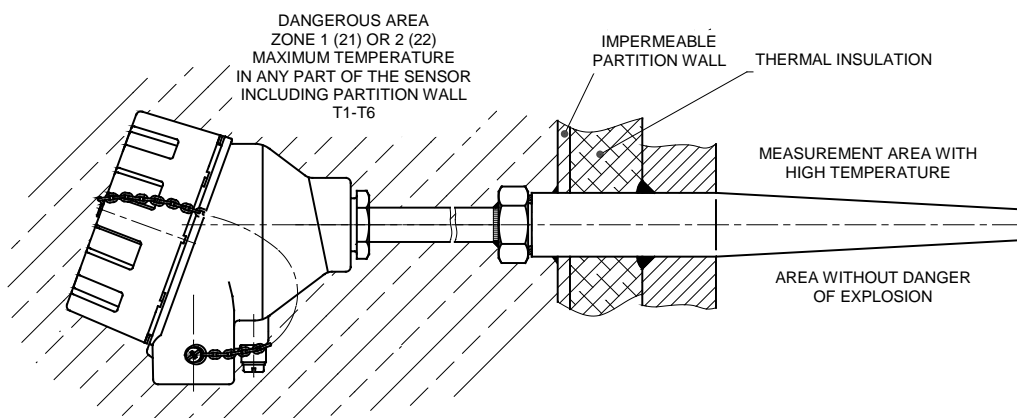

FIGURE 3 – EXAMPLE OF INSTALLATION OF TEMPERATURE SENSORS Ex d TO THERMOWELL DIN

(in case a higher limit of the measurement range is required on a level exceeding the required temperature class)



**FIGURE 4 – SCHEME OF CONNECTION OF TEMPERATURE SENSORS**

**SCHEME OF CONNECTION WITHOUT CONVERTER**

**J4** - With simple measuring resistor in four-wire connection (Pt 100/ /4)

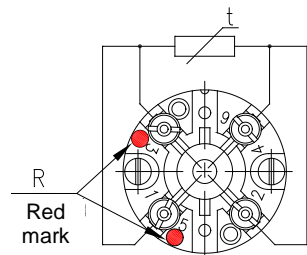

**D2** - With double measuring resistor in two-wire connection (2 x Pt 100/B/2)

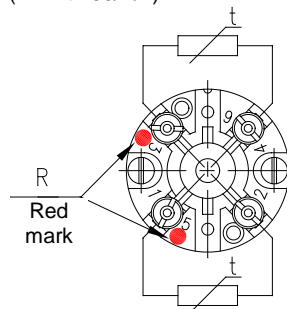

**D3** - With double measuring resistor in three-wire connection (2 x Pt 100/ /3)

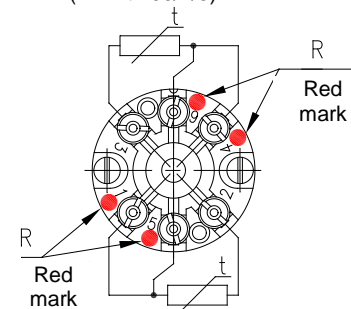

**SCHEME OF CONNECTION WITH CONVERTER AND DISPLAY**

with converter

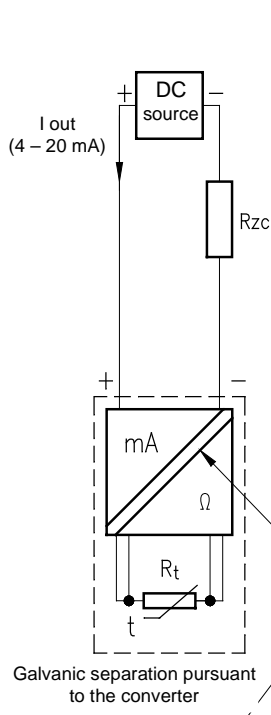

Galvanic separation pursuant to the converter

with converter with HART protocol

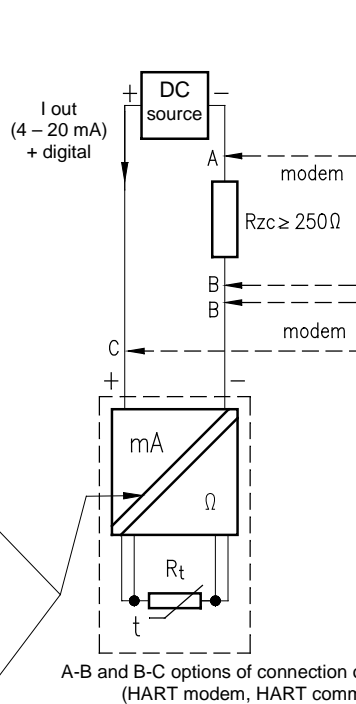

A-B and B-C options of connection of the control unit (HART modem, HART communicator)

with converter Ex ia

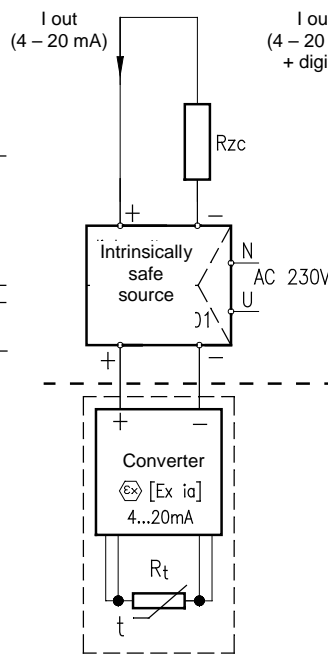

with converter Ex ia with HART protocol

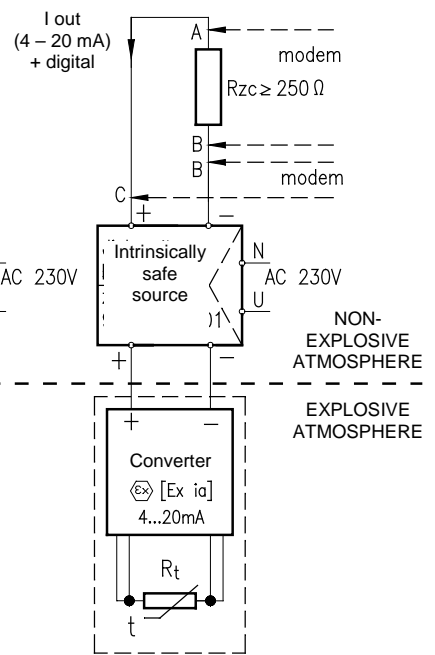

Rzc = total load resistor

NON-EXPLOSIVE ATMOSPHERE  
EXPLOSIVE ATMOSPHERE

**FIGURE 5- EXAMPLE OF OPERATION CONNECTION OF TEMPERATURE SENSOR WITH CONVERTER IN LOOP 4 - 20 mA**

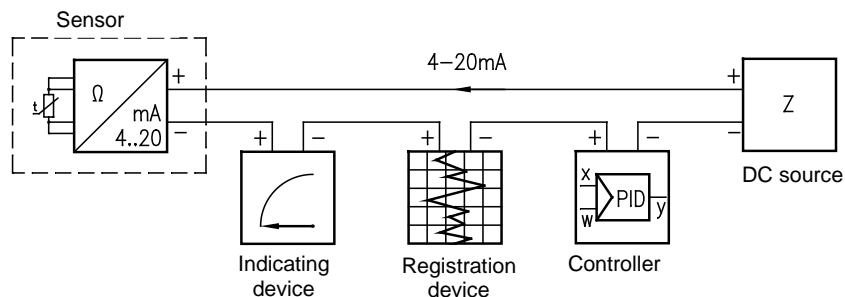

October 2018

© ZPA Nová Paka, a.s.

