



PRODUCT MANUAL

Resistance temperature sensor Ex d to heat sink DIN with connecting screw-joint on adapter without converter or with converter type series 230 type 235

FOR DESIGNS WITH CONVERTER A MANUAL IS ENCLOSED TO THE RELEVANT
CONVERTER

APPLICATION

- For exact remote measurement of temperature of steady and running liquids (gases and fluids), for which the properties of the heat sink of the sensor selected by the customer are suitable; measurement may be realized up to temperature (max. 450°C) and pressure determined by heat sink resistance
- For explosive environment pursuant to ČSN EN 60079-10 (ČSN EN 61241-10)
 - o Sensor may be installed into the heat sink located in zone 1(21) or zone 2(22); if the heat sink complies with the requirements pursuant to ČSN EN 60079-26, also in zone 0(20)
 - o Other parts of the sensor (screw-joint, adapter, connecting head) may be located in zone 1(21) or zone 2(22)
 - o In case of using the converter Ex ia or connection into circuit Ex ia, the sensor may be used in zone 0 (20)
- In a set with control or diagnostic systems for process monitoring
- In non-certified design for general temperature measurement
- In certified design as a part of rated meters for gas quantity converters, for flow meter of technical liquids or for balance heat measurement.
- In design with converter for transfer of resistance sensor signal to unified output signal 4 to 20 mA or digital signal (converter with HART protocol)

The sensors are rated products pursuant to the Act No. 22/1997 Coll. and Compliance Certificate **EC-235000** is issued for them.

DESCRIPTION

The sensor consists of a replaceable measuring insert with flange and ceramic terminal board or installed two-wire converter (insulated or non-insulated, even in design Ex i) and protective armature consisting of a head and an adapter with a screw-joint for the connection of the sensor into the heat sink selected by the customer. The head with measuring insert and outlet form a fixed closure Ex d. It is provided with a lid, which can be screwed, and a cable outlet for the connecting wiring. The cable outlet (pursuant to the required diameter of the cable) forms optional accessories to the sensor. The terminal board (of the converter) of the sensor is accessible after removing the lid of the head, which is fixed, after being tightened, with a pin against spontaneous releasing. The sensor is provided with an external clamp on the head for the connection of the grounding wire or wires for mutual interconnection.

The sensor with converter is supplied from an external source. The installed converter is pre-set to the required range at the sensor manufacturer.

To measure temperature, a defined change of thermoelectric voltage of the sensor in dependence on the change of temperature of the measured environment is used.

TECHNICAL DATA

The sensor design is based on DIN 43772. The sensor is designed pursuant to ČSN EN 61140 ed.2 as an electric equipment of protection class III for the application in networks with category of overvoltage in installation II and pollution grade 2 pursuant to ČSN EN 61010-1; the follow-up (evaluation) device shall comply with Article 6.3 of the said standard.

Measuring range:

Sensor with standard adapter $L_n = 135$ (125) mm
-70 to 450 °C

Sensor with shortened adapter $L_n \text{ min} = 65$ mm
-70 to 250 °C

The upper limit of the measuring range is limited by resistance of the material of the heat sink; however, it may not exceed 450°C. Measuring range of the sensor with converter is established by the range of the selected converter.

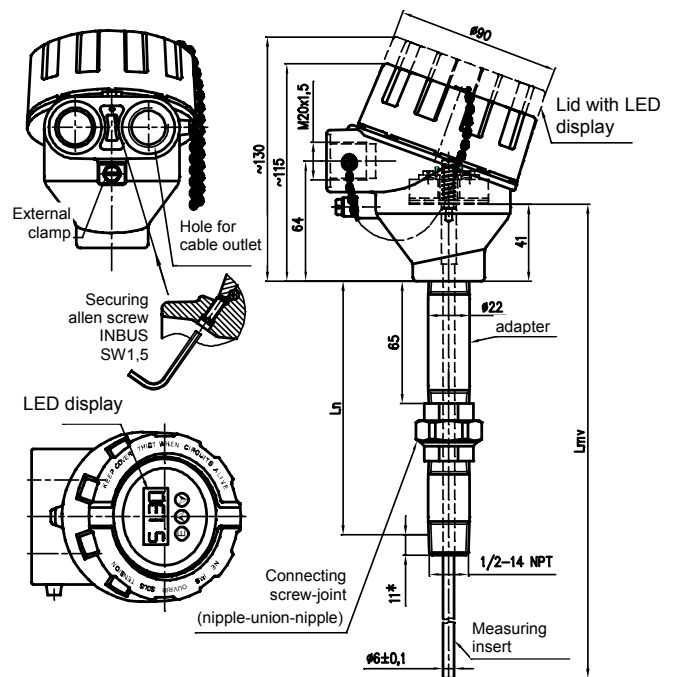

L	nominal length
L_n	length of adapter
L_{mv}	length of measuring insert
11*	standard length of screwing

Fixed closure pursuant to ČSN EN 60079-0 and ČSN EN 60079- and **dust-tight closure** pursuant to ČSN EN 50281-1-1: (Ex) II 1/2 GD Ex d IIC T1+T6 T=T media (meaning of designation refer to Figure 3 Mark of non-explosiveness page 8)

Electric strength pursuant to ČSN EN 61010-1, Article 6.8.4: 500 V eff

(only measuring insert without converter or design with insulated converter)

Electric insulation resistance pursuant to ČSN IEC 751, Article 4.2.1:
min. 100 MΩ, at 15 to 35°C, max. 80 % relative humidity

Power supply of converter:

DC 24 V from source SELV, e.g. INAP 16 and INAP 901

Other data of converter: refer to the enclosed manual
Coverage pursuant to ČSN EN 60529:
IP 68

Operation position:

discretionary; the outlet shall not be situated upwards

Type of operation:

continuous

Sensor weight:

with adapter 135 mm 0.93 kg

Applied materials:

Stem tube of measuring insert steel 1.4541

Adapter with connecting screw-joint	steel 1.4541
Head	aluminium alloy painted with blue epoxy colour
Internal wiring	Cu
Head clamps of the terminal board	brass with Ni surface
Connecting elements of the sensor	stainless steel

OPERATION CONDITIONS

The environment is defined by the group of parameters and their severity grades IE 36 pursuant to ČSN EN 60721-3-3 and the following operation conditions.

Ambient temperature for head and outlet of the sensor:

$-40\text{ °C} \leq T_a \leq 70\text{ °C}$

for design with converter pursuant to the type of converter (refer to the enclosed converter manual)

Maximum surface temperature of the sensor:

it complies with maximum temperature of the measured medium

Maximum surface temperature for equipment operating in the environment with a threat of explosion of gases, steam and mist pursuant to ČSN EN 60079-0 and temperature class of the sensor are determined in dependency on the temperature of measured medium pursuant to the following table:

Temperature class	Maximum surface temperature	Maximum temperature of measured medium
T6	85°C	85°C
T5	100°C	100°C
T4	135°C	135°C
T3	200°C	200°C
T2	300°C	300°C
T1	450°C	450°C

Maximum permitted surface temperature for the equipment operating in the environment with a threat of explosion of dust pursuant to ČSN EN 61241-14:

- a) Temperature limitation due to occurrence of stirred dust:

$T_{max} = 2/3 T_{ci}$

where T_{ci} is the temperature of ignition of stirred dust

- b) Temperature limitation due to occurrence of layers of dust to 5mm thickness: $T_{max} = T_{5\text{ mm}} - 75\text{ °C}$

where $T_{5\text{ mm}}$ is the temperature of ignition of dust layer 5mm thick

- c) Dust layers over 5 mm – refer to ČSN EN 61241-14

Maximum permitted surface temperature is defined by the lower value of the values specified above.



WARNING



The user shall guarantee that the maximum surface temperature of any part of the sensor does not exceed the temperatures of ignition of any gas, steam or dust, which can occur, due to external thermal effects.

Vibrations:

Sensor	with converter		without converter	
	Nominal length L [mm]	110, 140, 170	200, 260	110, 140, 170
Frequency range [Hz]	10 to 500			
Drift amplitude [mm]	0.2	0.15	0.5	0.2
Acceleration amplitude [ms ⁻²]	29.4	19.6	68.7	39.2

Relative ambient humidity:

10 to 100 % with condensation, with upper limit of water content 29 g H₂O/kg of dry air

Atmospheric pressure: 70 to 106 kPa

Maximum speed of flow of liquids:

pursuant to parameters of heat sink used by the customer

METROLOGICAL DATA

Probe: measuring resistor Pt 100 in connection pursuant to the scheme and table of designs, $\alpha = 0.00385\text{ [K}^{-1}\text{]}$, tolerance class A or B pursuant to ČSN IEC 751

Internal wiring resistance at 20 °C: 0.1 Ω/m

Calculated resistance value of internal wiring of the design without converter is specified on the label of the measuring insert.

Maximum current load of measuring resistor: 3 mA

Recommended measuring current: 1 mA

Output signal of the converter (linear with measured temperature):

4 to 20 mA (+ digital for HART protocol)

Calibration depth of immersion of the measuring insert of the sensor

for temperature points within range -70 to 250°C:

200 mm (min. 160 mm)

for temperature points above 250°C:

300 mm (min. 260 mm)

The distance of flange of the measuring insert from the level of medium in the calibration bath shall be at least 40 mm at temperatures to 250°C and min. 70 mm at temperatures above 250°C.

Temperature response time pursuant to ČSN IEC 751 in whirling water (characteristic value):

without heat sink (separate measuring insert) $\tau_{0.5}$ 5.5 s

with heat sinks pursuant to DIN 43772, shape 4

(L = 100, 140))

$\tau_{0.5}$ 85 s

$\tau_{0.9}$ 250 s

with heat sinks pursuant to DIN 43772, shape 4

(L = 200, 260))

$\tau_{0.5}$ 53 s

$\tau_{0.9}$ 115 s

DESIGNATION :

Data of head label

- Trademark of the manufacturer
- Made in Czech Republic
- Type of resistance sensor, nominal value R_0 / tolerance class / configuration of wires of internal wiring *)
- Measuring range or set-up converter range
- Product ordering number
- Coverage
- Mark and number of decision about approval of meter type in ČMI (for certified design)
- Manufacturing number
- Output signal 4 to 20 mA (design with converter)
- Ambient temperature $-40\text{ °C} \leq T_a \leq 70\text{ °C}$
- Mark of non-explosiveness:
 Ⓜ II 1/2 GD Ex d IIC T1+T6 T=T media
 and number of the EC Certificate of type test
- Designation of non-explosiveness and No. of EC Certificate of type test (for design with converter Ex i)
- CE mark 1026
- CE mark with identification number of notified person (for design with converter Ex i)

*) Configuration of wires of internal wiring is not specified for the converter

Data on label of measuring insert

- Trade mark
- Sensor type, nominal value R_0 / tolerance class / Configuration of wires of internal wiring *)
- Manufacturing number
- Resistance value of internal wiring (for design without converter)

*) Configuration of wires of internal wiring is not specified for the converter

Data on converter label

- Sensor type
- Pre-set temperature range

CERTIFICATION

- Non-explosiveness Ⓜ II 1/2 GD Ex d IIC T1+T6 T=T media
 EC Certificate of type test pursuant to the Decree of the Government No. 23/2003 Coll. FTZÚ 06 ATEX ?????X
- Non-explosiveness Ex i, EC Certificate of type test pursuant to the Decree of the Government No. 23/2003 Coll. (pursuant to the type of converter)
- Type approval of rated meter TCS ???????

DELIVERY

Unless agreed otherwise with the customer, each delivery includes

- Delivery note
- Sensor pursuant to the purchase order
- Allen key 1.5mm

- As accessories to sensors, a suitable cable outlet can be delivered; it shall be ordered separately pursuant to the catalogue of accessories, type 991. An instruction sheet is delivered with each cable outlet
 - Suitable heat sinks and weld-on pieces ordered separately pursuant to the catalogue of accessories, type 991
 - Optional accessories to the sensor with programmable converter
 - o Configuration (parameterization) programme pursuant to the required converter
 - o Communication modem (for serial port RS 232C) pursuant to the required converter
 - Accompanying technical documentation in Czech
 - o Product quality and completeness certificate, which also serves as the warranty certificate
 - o EC Compliance Certificate
 - o Calibration sheet (for uncertified calibrated design)
 - o Product manual
- If it is established in the purchase contract or agreed otherwise, the following documentation can be also delivered with the product
- Copy of the Inspection Certificate 3.1 for material of stem tube and heat sink with the casting number
 - Copy of EC Certificate of type test pursuant to the Decree of the Government 23/2003 Coll. for fixed closure
 - Copy of EC Certificate of type test pursuant to the Decree of the Government 23/2003 Coll. for design with converter Ex i
 - for certified design
 - o Confirmation about certification of rated meter
 - o Copy of decision about approval of meter type in ČMI

PACKING

Both sensors and accessories are delivered in a packing ensuring resistance to the impact of thermal effects and mechanical effects pursuant to controlled packing regulations.

TRANSPORT

The sensors may be transported on conditions corresponding to the set of combinations of classes IE 21 pursuant to ČSN EN 60721-3-2 (i.e. by airplanes and trucks, in premises that are ventilated and protected against atmospheric conditions).

STORAGE

The sensors may be stored on conditions corresponding to the set of combinations of classes IE 11/1K3 pursuant to ČSN EN 60721-3-1 (i.e. in places with temperature from -5 to 45 °C and humidity from 5 to 95%, without a special threat of an attack with biological agents, with vibrations of small significance and not situated close to sources of dust and sand).

DESIGN OF TEMPERATURE SENSORS Ex d TO HEAT SINK, TYPE 235

SPECIFICATIONS					ORDERING NUMBER										
					235	x	x	0	x	x	x	x	/xxxxxx	/xxx	
Nominal length L [mm]	110	Length of adapter L _n [mm]	125	Length of measuring L _{mv} [mm]	275	1	1								
	140				315	2									
	170				335	3									
	200		135			375		4							
	260					435		5							
	410					585		6							
	Other (min. 75 *)							9							
Nominal length L [mm]	110	Length of adapter L _n [mm]	65 (Without connecting screw-joint)	Length of measuring L _{mv} [mm]	215	1	2								
	140				245	2									
	170				275	3									
	200				305	4									
	260				365	5									
	410				515	6									
	Other (min. 75 *)					9									
Length of adapter		135mm (125mm)				1									
		65 mm (without connecting screw-joint *) max. -70 to 250 °C				2									

		Other *)**) (min. 65 mm)		9						
Connecting thread		1/2-14 NPT			5					
Sensor head with thread for outlet(Ex d)		M20x1.5				1				
		1/2-14NPT *)				2				
Measuring resistor (probe)		Pt100				1				
Tolerance class		A *)					A			
		B					B			
Terminal board connection (Pt100)		Single - four-wire (1xPt)						/J4		
		Double- two-wire (2xPt/B)					B	/D2		
Certified design	-50 to +50°C	Application	Natural gas					/O1		
	-50 to +100°C		Technical gases					/O2		
	0 to +200°C		Condensate or saturated steam					/J4	/O3	
	0 to +450°C		Overheated steam						/O4	
Converter type			Galvanic separation	Ex	Range [°C]					
Analogue	INPAL 420				-50 to 50				/O7	
					-30 to 70				/55	
					0 to 50				/15	
					0 to 100				/18	
					0 to 150				/19	
					0 to 200				/20	
					0 to 250				/21	
					0 to 400	1			/23	
APAQ-HRF					Adjustable range			/HRF		
APAQ-HRFX *)				•				/HRFX		
Programmable					Programmable range	TK-L			1	/TKL
						TK-L-ex *)				/TKLX
						TK	•			/TK
						TK-ex *)	•	•		/TKX
						IPAQ-H	•			/IPAQH
						IPAQ-HX *)	•	•		/IPAQHX
HART protocol					Programmable range	MINIPAQ-H				/MINIPAQ
						TK-H	•			/TKH
						TK-H-ex *)	•	•		/TKHX
						MESO-H	•			/MESOH
						MESO-HX *)	•	•		/MESOHX
644 H NA								/644HNA		
644 H I1 *)								/644HI1X		
LED display to loop 4-20mA (only with converter)										
LED display *)										
LED display-ex (only for converter Ex) *)										

Standard design

*) only as a special requirement after an agreement with the manufacturer
 **) In case of adapter length below 125 mm (minimum 65 mm), the temperature range is decreased to -70 to 250 °C.

ORDERING TEMPERATURE SENSORS

The purchase order shall specify

- Name
- Product ordering number
- Measuring range
- If calibration is required and in what temperature points
- If certification is required and the type of application
- If certification in temperatures below zero (minus) is required
- If the delivery of heat sink and weld-on piece pursuant to the type 991 is required for the sensor as accessories
- If the delivery of outlet for output cable pursuant to the type 991 is required for the sensor as accessories
- If optional accessories to the sensor with programmable converter is required
- Other (special) requirements
- Number of pieces

Behind the ordering number specified pursuant to the above mentioned table, the customer shall identify the required range of measured temperature (i.e. lower and upper temperature limits in °C) and, as the case may be, other non-standard required parameters for converter configuration (e.g. indication of sensor tripping, dampening, required designation - tagging etc.).

If the sensor is required for the application as a part of the rated meter (SM), a requirement for certification and type of application shall be added, too.

PURCHASE ORDER EXAMPLE

Standard design:

1. Resistance temperature sensor Ex d to heat sink DIN

- with connecting screw-joint on adapter
without converter
235 410 511B/J4/O1
range -50 to 50°C
certification for natural gas
We request a delivery of the "Confirmation about certification of rated meter" with the sensor".
6 pcs
- 2. Resistance temperature sensor Ex d to heat sink DIN
with connecting screw-joint on adapter
without converter
235 210 511B/J4
range -70 to 450°C
6 pcs

Special requirement:

Resistance temperature sensor Ex d to heat sink DIN
with connecting screw-joint on adapter
with converter
235 910 511B/18
nominal length L 380 mm
range 0 to 100°C
6 pcs

ORDERING HEAT SINKS

The purchase order shall specify:

- Name
- Product ordering number
- Number of pieces

PURCHASE ORDER EXAMPLE

Standard design:

Welding heat sink pursuant to DIN, shape 4
991 DIN 407544 20 pcs

ORDERING WELD-ON PIECES

The purchase order shall specify:

- Name
- Ordering number of weld-on piece
- Number of pieces

ORDERING NUMBERS OF WELD-ON PIECES, type 991

- Weld-on piece - 991 NVD4 D24 51 (material 15 128.5)
- 991 NVD4 D26 51 (material 15 128.5)
- 991 NVD4 D24 72 (material 1.4541)

- 991 NVD4 D26 72 (material 1.4541)

ORDERING OUTLETS

The purchase order shall specify:

- Name
- Ordering number of outlet
- Number of pieces

ORDERING NUMBERS OF OUTLETS, type 991

- Outlet M 20 x 1.5 (with clamp against cable pull-out)
 - for cable Ø4 8.5mm VM 408
 - for cable Ø 6 12mm VM 612
 - for cable Ø 8.5 16mm VM 816
 (the set consists of the outlet itself, cable clamp and sealing under outlet Ø20x24)
- Outlet 1/2-14NPT (with clamp against cable pull-out)
 - for cable Ø 4 8.5mm VK 408
 - for cable Ø 6 12mm VK 612
 - for cable Ø 8.5 15.5mm VK 815
 (the set consists of the outlet itself and cable clamp)

HEAT SINKS RECOMMENDED FOR ASSEMBLY OF TEMPERATURE SENSORS TO HEAT SINK - TYPE 991

SPECIFICATIONS					ORDERING NUMBER									
					991	DIN	x	x	x	x	x	x		
Heat sink with cone pursuant to type 991	Welding	Heat sink, shape 4 pursuant to DIN 43772	Without flange PN 250			4	0							
			With flange **)			4	F							
		Inner bore [mm]							7					
		Inner thread / outer Ø of heat sink		1/2-14 NPT / Ø 26 *)							5			
Nominal length of heat sink L [mm]	L1 [mm]	L2 [mm]	65	105									1	
			65	140									2	
			133	170									3	
			65	200									4	
			125	200									5	
			125	260									6	
			275	410									7	
			Other (max. 410) *)											9
Heat sink material (***)	For zone 1 and 2	Maximum operation temperature	1.7335 *)	550 °C									1	
			1.7380	580 °C									2	
	For zone 0, 1 and 2	Pursuant to heat sink material ****)	1.4541	580 °C									3	
			1.4571	400 °C									4	
	Other *)		Pursuant to heat sink material										9	

- *) Upon a special requirement after an agreement with the manufacturer
- **) Flange design (shape, PN, DN and material) pursuant to the requirement of the customer
- ***) Surface treatment of heat sinks from material 1.7335 and 1.7380: preservation with grease - oil
- ****) For zone 0, heat sink from corrosion resistant steel shall be used (pursuant to ČSN 60079-26)

CERTIFICATION PURSUANT TO ACT 505/1990 Coll.

The sensors are certified pursuant to TPM 3342-94 for condensate and steam or pursuant to TPM 6890-95 for natural gas and technical gases.

Certified sensors are provided with a label with an official mark of the certification. The label is sealed on the terminal board and head of the sensor.

A confirmation about certification of a rated meter can be issued for a certified sensor upon request of the customer later on.

The purchase order shall specify:

- Delivery note number that was delivered with the sensor
- Product ordering number *)
- Manufacturing number

*) Data can be found on the device label

The manufacturer performs follow-up certification pursuant to the Act 505/1990 Coll., on metrology, as amended. Follow-up certification shall be ordered with the AMS department ZPA N. Paka a.s.

TYPE OF LOCATION OF MARK OF THE INSTALLATION AND SERVICE

ORGANIZATION AND OFFICIAL MARK OF THE CERTIFICATION

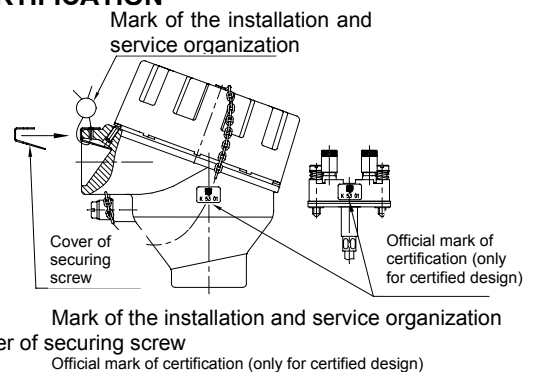

CALIBRATION

Calibration can be realized for the sensors, which are not used as parts of rated meters (i.e. they are not certified). It is realized pursuant to TPM 3342-94 and in compliance with ČSN IEC 751, usually in three temperature points evenly

distributed within the operation range of the sensor or in the points according to the requirement of the customer. Calibration sheets with measured data are issued for calibrated sensors.

INSTALLATION AND CONNECTION

SENSOR INSTALLATION

Install the sensors by screwing into the relevant heat sink screwed into the weld-on piece on the piping (technological equipment) or welded into the piping wall. Before the installation, put on the enclosed sealing ring in advance. During the installation, torque of 70 Nm is recommended.

With respect to maintaining metrological properties and the longest possible service life, it is not recommended to install the sensors in places with high turbulence of the medium, which is caused e.g. by a rapid transition from a small diameter of the piping to a larger one (when failing to comply with the required shape and dimensions of diffuser behind the flow meter), etc. Recommended distance of the temperature sensor from the installation flange of the flow meter is min. 1 m.



WARNING

The temperature sensor is only certified as design with closure Ex d as a set with a heat sink.

Distance of the fixed closure  II 1/2 GD Ex d IIC from close structures or between the suspensions shall be at least 40 mm.



EXAMPLES OF INSTALLATION OF HEAT SINKS DIN

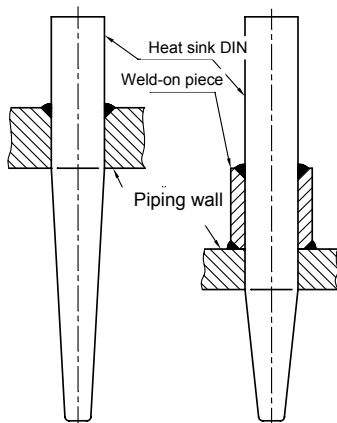

INSTALLATION OF CABLE OUTLET

To secure the fixed closure, only the certified cable outlet  II 2 GD Ex d IIC with coverage IP 68 shall be used (refer to accessories 991 or another similar outlet). It shall be tightened in the sensor head in the prescribed way.

Torque of outlet body:

- | | | |
|----|------------------------------------|-----------|
| a) | for outlet with thread 1/2 - 14NPT | 25 – 30Nm |
| b) | for outlet with thread M20x1.5 | 30 – 35Nm |

Installation of the cable in the outlet, its sealing and securing against pull-out shall be realized pursuant to the instruction sheet of the outlet supplier.



WARNING

Do not use other sealing rings in the outlet than the original ones delivered by the manufacturer. Do not change artificially the outer diameter of the cable e.g. by winding it around with electrical insulating tapes.

ELECTRICAL CONNECTION

The electrical connection may be only realized by qualified workers pursuant to § 5 of the Decree 50/1978 Coll.

The sensor installation in conditions with explosive gaseous atmosphere shall comply with the requirements of ČSN EN 60079-14 ed. 2.

The sensor installation in conditions with flammable dust shall comply with the requirements of ČSN EN 61241-14.

The terminal board of the sensor (converter) is accessible after the removal of the lid of the head.

Connect the evaluation devices to the sensor with a non-armoured cable with double insulation (internal wires with Cu core with cross-section 0.5 to 1.5 mm²). Seal the cable in the outlet by prescribed tightening of the closing nut pursuant to instruction sheet of the outlet. Then secure it with clamp against pull-out.



WARNING

Do not use independent wires without jacket for electrical connection. To ensure the coverage grade in the outlet, the connecting cable shall have circular cross-section. Temperature resistance of the cable shall comply with the ambient temperature! Its permanent temperature resistance to at least 70°C is required.

The cable insulation shall have chemical and mechanical resistances in compliance with the conditions, in which the cable will be installed. It is recommended supporting the cable along its length between the sensor and the follow-up device. In the environment with interfering signals, use shielded cable in the power supply circuit. Shielding may be only grounded (earthed) in one point. The cable should not be placed together with power cables.

In case of the sensor with HART protocol converter, the maximum length of wiring is defined by the arrangement of wires of the connecting cable. The total length of wiring may be up to 1500 m. It requires a twisted two-wire with shared shielding with the diameter of the cross section min. 0.5 mm². Recommended HART communicator, model 275, is connected to the supply loop of the sensor with converter pursuant to Figure 1 - Scheme of temperature sensor connection page 8. To achieve reliable communication, resistor 250 Ω shall be introduced in the circuit of the output loop.



WARNING

Programmable converter may not be connected to a computer or a HART communicator if the converter is located in explosive environment.



WARNING for sensor with converter Ex i

Ex i parameters shall be complied with pursuant to the enclosed converter manual.

To ensure safety, a spark-safe source shall be always used pursuant to the converter manual, e.g. INAP 901 ordering number 901 000 101.

Surface temperature of the converter may not exceed maximum surface temperature for that particular temperature class.



For the installations in dangerous areas, mutual connection is required (bringing to the same potential). To achieve it, clamps on the sensor head can be used.

The sensor need not be connected to the system of mutual connection independently if it is installed firmly and has metal interconnection with the structural parts of piping, which is connected to the system of mutual connection.

SENSOR HEAD WITH CLAMPS

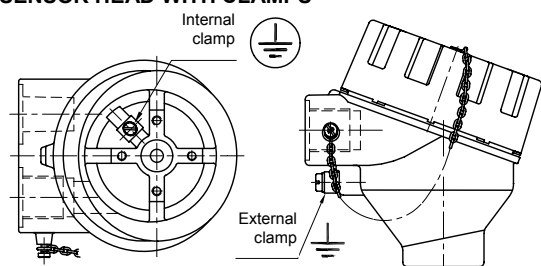

Maximum cross-section of wire for connection to external and internal clamps:

Internal clamp: stranded wire 1.5 mm², full wire 2.5 mm²

External clamp: stranded wire 4.0 mm², full wire 6.0 mm²

If stranded wires are used for the interconnection, they shall be protected against fraying with pressing hollow.

CLOSING HEAD OF FIXED CLOSURE Ex d

After electrical connection of the sensor, the lid of the head shall be fully tightened by hand, then released slightly to ensure matching with the closest groove against the securing pit and fixed by this screw against releasing. If the lid of the sensor is not tightened and secured by the above mentioned screw, the sensor does not comply with the requirements of fixed closure Ex d.



WARNING:

Electric supply of the sensor may not be connected before closing the fixed closure!



INSTALLATION OF RATED METER

The installation, commissioning and service maintenance of rated meters pursuant to the Act 505/1990 Coll., on metrology, may only be performed by a person that is a bearer of a valid Authorization for installation and maintenance of rated meters issued e.g. in ZPA Nová Paka a.s.

After the installation, the certified sensors are provided with a mark of the installation and service organization by an authorized worker of the installation and service organization.

COMMISSIONING

After the sensor installation, including the fixed closure, and connection of the follow-up (evaluation) device to the supply voltage (and the settlement period of the converter), the equipment is prepared for operation.

OPERATION AND MAINTENANCE

The sensor does not require any operation and maintenance.



WARNING

Any intervention into the sensor and its structure will result in a change of properties and can result in an explosion!



With respect to rated meters, the established period for follow-up certification shall be complied with in the intervals identified by the Decree of the Ministry of Industry and Trade 345/2002 Coll. The replacement and connection of sensors to be verified are performed by an authorized worker of the installation or service organization, who shall seal the sensor again.

The official mark on the measuring insert may only be broken by a worker of AMS. If the official mark has been broken or removed, validity of certification of the meter is terminated.

SENSOR UNINSTALLATION

The installation seal may only be broken by a worker of the installation and service organization.



WARNING



Warning: Temperature sensor is in design Ex and must be disconnected from the power supply source before opening the lid of the head and releasing the cable outlet in the explosive environment!

Then release the securing screw of the lid by ALLEN key 1.5 mm (a part of accessories). The terminal board of the sensor (converter) is accessible after unscrewing the lid of the head. Measuring insert of the sensor can be replaced and is uninstalled from the head after disconnecting the cable by releasing two screws.

Before a complete uninstallation of the sensor, the wire for mutual interconnection shall be released from the external clamp on the sensor.

Disconnect the connecting cable from the terminal board, then release it from the clamp on the outlet and from closing nut of the outlet. Unscrew the sensor from the heat sink; torque for releasing is approx. 70 Nm. While releasing the screw-joint of the sensor, the heat sink may never be released.

SPARE PARTS

Spare parts shall be delivered by the manufacturer.

Relevant measuring inserts can be ordered pursuant to the offered price list of spare parts.

Certified measuring inserts are provided with a label with an official mark. The label with the mark is located on the terminal board of the measuring insert.

WARRANTY

Pursuant to § 429 of the Commercial Code and the provisions of § 620 (2) of the Civil Code, the manufacturer warrants for technical and operation parameters of the product specified in the manual. The warranty period is 24 months from the receiving of the product by the customer, unless established otherwise in the contract. Rejection of defects shall be enforced in writing at the manufacturer within the warranty period. The rejecting side shall identify the product name, ordering and manufacturing numbers, date of issue and number of the delivery note, clear description of the occurring defect and the subject of the claim. If the rejecting side is invited to send the device for repair, it shall do so in the original package of the manufacturer and/or in another package ensuring safe transport.

The warranty shall not apply to defects caused by unauthorized intervention into the device, its forced mechanical damage or failure to comply with operation conditions of the product and the product manual.

REPAIRS

The sensors shall be repaired by the manufacturer. They shall be sent for repair in the original or equal package without accessories.

DISABLING AND LIQUIDATION

They shall be realized in compliance with the Waste Act No. 106/2005 Coll.

The product and its package do not include any parts that could impact the environment.

Products that are withdrawn from operation, including their packages (with the exception of products marked as electrical equipment for the purposes of return withdrawal and separate salvage of electrical waste), may be disposed of to sorted or unsorted waste pursuant to the type of waste.

The manufacturer realizes free return withdrawal of marked electrical equipment (from 13.8.2005) from the consumer and points out the danger connected with their illegal disposal. The package of the sensor can be recycled completely. Metal parts of the products are recycled, non-recyclable plastic materials and electrical waste shall be disposed of in compliance with the aforesaid Act.

FIGURE 1 - SCHEME OF TEMPERATURE SENSOR CONNECTION
without converter with converter

with single measuring resistor
in four-wire connection
(Pt 100/ 4)

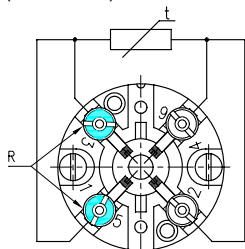

with double measuring resistor
in two-wire connection
(2 × Pt 100/B/2)

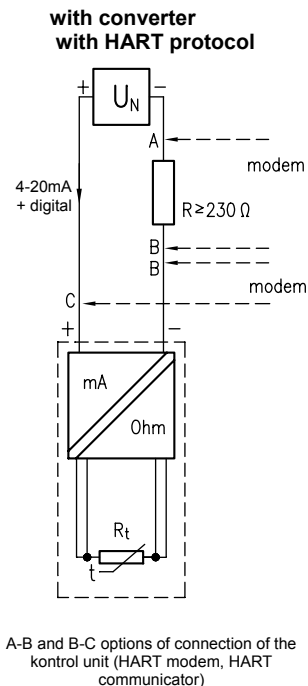
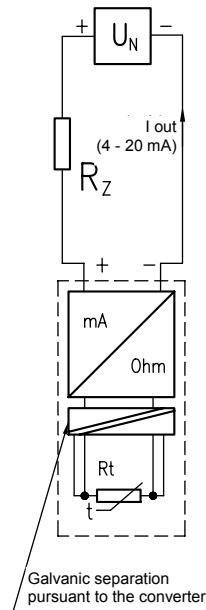
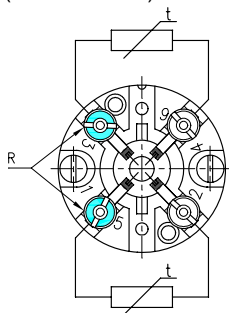

FIGURE 2- EXAMPLE OF OPERATION CONNECTION
of temperature sensor with converter in loop 4 - 20 mA

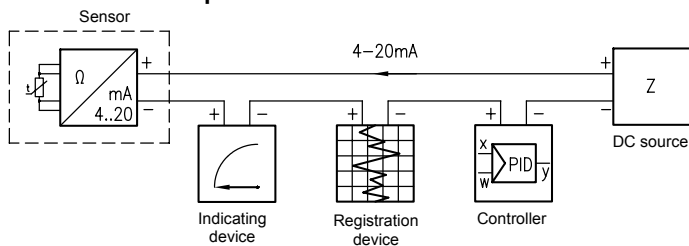
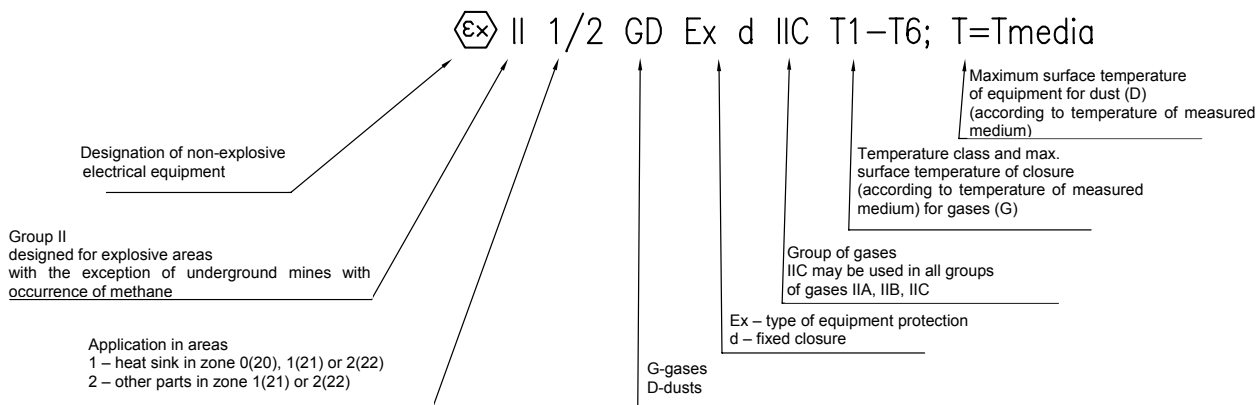

FIGURE 3 MARK OF NON-EXPLOSIVENESS



March 2006

© ZPA Nová Paka, a.s.



NOVÁ PAKA

ZPA Nová Paka, a. s.
Pražská 470
509 39 Nová Paka

tel.: spojovatel: 493 761 111
fax: 493 721 194
e-mail: obchod@zpanp.cz

www.zpanp.cz
bankovní spojení: ČSOB Trutnov
číslo účtu: 271 992 523/0300

IČO: 46 50 48 26
DIČ: CZ46504826

