



PRODUCT MANUAL

Resistance temperature sensor Ex d (Ex t, Ex i) with metal or ceramic protective tube without converter or with converter type series 250 type 252

FOR DESIGNS WITH CONVERTER A MANUAL IS ENCLOSED TO THE RELEVANT CONVERTER
FOR DESIGN WITH CONVERTER AND DISPLAY A MANUAL IS ENCLOSED TO THE RELEVANT CONVERTER AND DISPLAY

APPLICATION

- For remote measurement of temperature of gases, for which the properties of the material of the protective tube are suitable (e.g. in furnaces)
- For environment with explosive gaseous atmosphere according to EN 60079-10-1 and explosive atmospheres with combustible dust according to EN 60079-10-2
 - o Thermowell of the sensor may be installed in Zone 0(20), Zone 1(21) or Zone 2(22)
 - o Other parts of the sensor (screw union, adapter, connecting head) may be located in Zone 1(21) or Zone 2(22)
 - o In case of application of the converter Ex ia or connection to Ex ia circuit according to EN 60079-25, the sensor may be used in Zone 0 (20), 1 (21) and 2 (22)
- In a set with control or diagnostic systems for process monitoring
- In design with converter to convert signal of the resistance sensor to unified output signal 4 to 20 mA or digital signal (converter with HART protocol)
- In design with display to display the value of the measured value
- For the environment, where mechanical resistance is required pursuant to EN 60068-2-6 (class AH2) and seismic capability of the electrical equipment of the safety system of the nuclear power stations pursuant to IEC 980 (MVZ level SL-2)
- special design for cryogenic environment with medium temperature up to -196 °C

The sensors are rated products pursuant to the Directive, 2014/30/EU of the European Parliament and the Council and EU Declaration of Conformity **EU -252000** is issued for them.

Using sensors within the meaning of Directive 2014/32 EU of the European Parliament and the Council. (MID) as part of the customer's measurement kits, for which the conformity of the assemblies as a whole must be assessed when placed on the market with all the features required by this directive:

- sensor without transmitter in 1xPt100 /.. / 4 connection can be used by the customer on the basis of an evaluation certificate in its measuring sets in the sense of Directive 2014/32 EU of the European Parliament and the Council

DESCRIPTION

The sensor consists of a replaceable measuring insert with a flange and ceramic terminal board or installed two-wire converter (insulated or non-insulated, even in design Ex ia) and protective armature, consisting of a head and a protective tube. The head is provided with a lid and a cable outlet for the connecting wiring. The terminal board (of the converter) of the sensor is accessible after unscrewing the lid of the head, which is connected with one screw. On its head, the sensor with

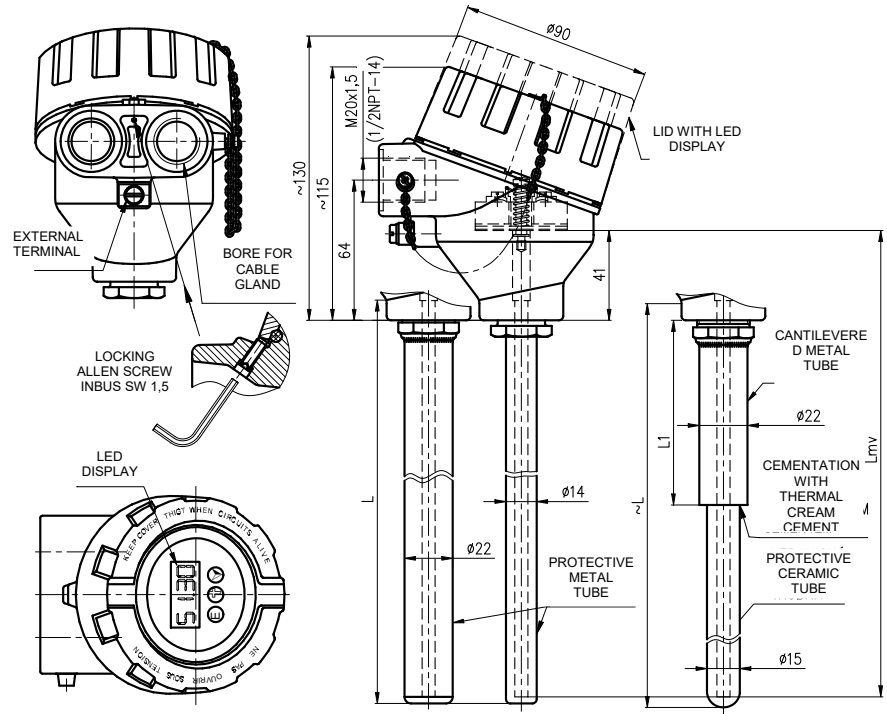

- 1 - Ball head (Al alloy)
(for converter Ex i with both external and internal terminals) or plastic ball head
(It cannot be used for converter Ex i)
 - 2 - Ball head with increased lid (Al alloy) without display for converter in the lid or with display
(for converter Ex i with both external and internal terminals)
 - 3 - Small ball head (Al alloy)
(only for terminal board or converter INPAL 420 APAQ-HRF, TH 100, MINIPAQ-HLP)
 - 4 - Cable outlet M20x1.5
- L Nominal length
L1 - Length of supporting metal tube
L_{mv} Length of measuring insert

converter in design Ex ia is provided with an external terminal and an internal terminal for the connection of the grounding wire or the wire for mutual interconnection.

The converter is installed either directly on the flange of the measuring insert or in the lid of the head.

The sensor with converter is supplied from an external source. The installed converter is pre-set to the required range at the sensor manufacturer.

To measure temperature, a defined change of sensor resistance in dependence on the change of temperature of the measured environment is used.

TECHNICAL DATA

The sensor dimensions are based on DIN 43772 and original ČSN 25 8301. The sensor is designed pursuant to EN 61140 as an electrical equipment of protection class III for the application in networks with category of overvoltage in installation II and pollution grade 2 pursuant to EN 61010-1; the follow-up (evaluation) device shall comply with Article 6.3 of the said standard.

Measuring range: -70 to 600 °C *) **) -196 to 100 °C **) ***)

*) The upper limit of the measurement range is limited by resistance of the material of the applied protective tube; however, it must not be higher than the upper limit of the range according to the sensor used.

If it is ensured with a suitable way of installation that the surface temperature of the part of the sensor located in dangerous area does not exceed the temperature of the required temperature class (T1...T6), the upper limit of the range of measurement may be even higher (max. 600°C). For an example of installation, refer to figure 6.

**) Class A is only guaranteed in the range from -70 to 300 ° C
 ***) Special design for cryogenic environments

Measuring range of the sensor with converter is given by the range of the selected converter.

Design for explosive atmospheres with metal protective tube:

Fixed closure pursuant to EN IEC 60079-0 and EN 60079-1,

 II 1/2 G Ex db IIC T1...T6 Ga/Gb

(Meaning of designation - see Figure 3)

Dust-tight closure pursuant to EN IEC 60079-0 and EN 60079-31:

 II 1/2 D Ex ta/tb IIIC T=T media Da/Db

(Meaning of designation - see Figure 3)

Design for explosive atmospheres with ceramic protective tube:

Fixed closure pursuant to EN IEC 60079-0 and EN 60079-1,

 II 2 G Ex db IIC T1...T6 Gb

(Meaning of designation - see Figure 3)

Dust-tight closure pursuant to EN IEC 60079-0 and EN 60079-31:

 II 2 D Ex tb IIIC T=T media Db

(Meaning of designation - see Figure 2)

Intrinsically safe pursuant to EN IEC 60079-0 and EN 60079-11:

 II 1 G Ex ia IIC T5/T6 Ga

(Meaning of designation - see Figure 4)

P_i = 192 mW T6 (-60°C ≤ Ta ≤ 60°C)

P_i = 290 mW T6 (-60°C ≤ Ta ≤ 55°C)

T5 (-60°C ≤ Ta ≤ 65°C)

Intrinsically safe circuit parameters:

only for Pt 100, with measuring insert Ø6

Input

U_i = 60 V

I_i = 100 mA

P_i = 192 mW / 290 mW

C_i = 780 pF/m

L_i = 0,6 µH/m



WARNING

The device must be installed in a housing that meets the degree of protection against intrusion of at least IP 20.

The casing of the measuring insert is not separated from the inner intrinsically safe circuit according to the standard EN 60079-11. This information must be taken into account during installation.

Intrinsically safe version with converter:

according to built-in converter

Electric strength pursuant to EN 61010-1 Article 6.8.3:

500 V eff (only measuring insert without converter or design with insulated converter)

Electric insulation resistance pursuant to EN 60751:

min. 100 MΩ, at 15 to 35°C, max. 80 % relative humidity
 min 100 V DC

Power supply of the converter:

DC 24 V from source SELV, e.g. INAP 16 and INAP 901

Other data of the converter: refer to enclosed manual

Display: LED display to loop 4-20mA

other date refer to enclosed manual

Ingress protection pursuant to EN 60529:

Sensor with metal protective tube IP 65

Sensor with ceramic protective tube IP 65/IP60

(IP65 – sensors head, IP60 – protective tube)

Sensor weight:

With ball head (Al alloy)

Nominal length L	350 mm	approx. 1.06 kg
	500 mm	approx. 1.20 kg
	710 mm	approx. 1.38 kg
	800 mm	approx. 1.46 kg
	1000 mm	approx. 1.64 kg
	1400 mm	approx. 1.99 kg
	1600 mm	approx. 2.17 kg
	2000 mm	approx. 2.52 kg

Operation position:

discretionary; the outlet shall not be situated upwards

Type of operation: continuous

Applied materials:

Protective tube	Steel	1.4541
		1.4749
		1.4845 or 1.4841
gas-tight ceramics	LUNIT 73 (content approx. 60 % Al ₂ O ₃) corresponds to a subgroup C 610 pursuant to EN 60672-3)	
	LUXAL 203 (content min. 99,5 % Al ₂ O ₃) corresponds to a subgroup C 799 pursuant to EN 60672-3)	
Tube of measuring insert	Steel 1.4541	
Cantilevered metal tube for ceramic tube	Steel 1.4541	
Head	aluminium alloy painted with polyester paint	
	plastic PPO (phenyl polyoxide)	
Sealing of lid of head and gland	oil-resistant rubber	
Internal wiring	Cu	
Head terminals of terminal board	brass with Ni surface	

OPERATION CONDITIONS

The environment is defined by the group of parameters and their severity grades IE 36 pursuant to EN 60721-3-3 and the following operation conditions.

Ambient temperature for head and gland of the sensor:

- for design without converter -50 °C ≤ Ta ≤ 85 °C
- for design with converter pursuant to the type of converter (refer to the enclosed converter manual) max. -50 °C ≤ Ta ≤ 75 °C
- for design with converter and display pursuant to the type of converter and display (refer to the enclosed converter and display manual) max -50 °C ≤ Ta ≤ 75 °C

Maximum surface temperature of the sensor:

it complies with maximum temperature of the measured medium

Maximum surface temperature for equipment operating in the environment with a threat of explosion of gases, steam and mist pursuant to EN 60079-0 ed. 2 and temperature class of the sensor are determined in dependency on the temperature of measured medium pursuant to the following table:

Temperature class	Maximum surface temperature	Maximum temperature of measured medium
T6	85°C	80°C
T5	100°C	95°C
T4	135°C	130°C
T3	200°C	195°C
T2	300°C	290°C
T1	450°C	440°C

Maximum permitted surface temperature for the equipment operating in the environment with a threat of explosion of dust pursuant to EN 60079-0:

- Temperature limitation due to occurrence of stirred dust:
 $T_{max} = 2/3 T_{cl}$
 where T_{cl} is the temperature of ignition of stirred dust
- Temperature limitation due to occurrence of layers of dust to 5 mm thickness: $T_{max} = T_{5\text{mm}} - 75 °C$
 where T_{5 mm} is the temperature of ignition of dust layer 5 mm thick
- Dust layers over 5 mm – refer to EN 60079-14

Maximum permitted surface temperature is defined by the lower value of the values specified above.

Intrinsically safe measuring inserts can be used in intrinsically safe circuits of group II electrical equipment.



WARNING

The user shall guarantee that the maximum surface temperature of any part of the sensor does not exceed the temperatures of ignition of any gas, steam or dust, which can occur, due to external thermal effects.

Relative ambient humidity:

- 10 to 100 % with condensation, with upper limit of water content 29 g H₂O/kg of dry air
- for converter version according to converter type (see enclosed converter instructions)



- for converter and display version according to converter and display type (see enclosed converter and display instructions)

Atmospheric pressure: 70 to 106 kPa
Maximum speed of flow of gaseous medium: 2 m/s

Vibrations:

Nominal length L [mm]	350 to 1000	1400 to 2000
Frequency range [Hz]	10 to 55	
Drift amplitude [mm]	0.15	0.075
Acceleration amplitude [ms ⁻²]	19.6	9.8

Application of protective tube material:

Material	Resistance in the atmosphere			
	sulfuring		nitrogening, poor on oxygen	carbonizing
	oxidative	reductive		
1.4845	good	low	good	satisfactory
1.4841				
1.4749	very good	good	low	low
1.4541	good	low	good	satisfactory
LUNIT 73 *)	very good (suitable for alkaline-free gases and hydrofluoric acid)			
LUXAL 203 *)	very good (contact with alkali vapors allowed to 1500 °C)			

Degree of resistance: 1 – very good 3 – satisfactory (middle)
 2 – good 4 – low (unsatisfactory)

*) material suitable for abrasive media, highly chemically resistant and refractory, very fragile, resistance against sudden change of temperature min. 150 K, bending strength for LUXAL 203 is min. 300 MPa, for LUNIT 73 min. 120 MPa

METROLOGICAL DATA

Sensing probe: measuring resistor Pt 100 in connection pursuant to scheme and table of designs, $\alpha = 0.00385 [K^{-1}]$, tolerance class A or B pursuant to EN 60751

Internal wiring resistance at 20 °C: 0.1 Ω /m
 The calculated resistance value of internal wiring is specified on the label of the measuring insert for the design without converter.

Maximum current load of measuring resistor:

Pt 100 3 mA
 Pt 500 1 mA

Recommended measuring current:

Pt 100 1 mA
 Pt 500 0,5 mA

Output signal of the converter (linear with measured temperature):
 4 to 20 mA (+ digital for HART protocol)

Calibration depth of immersion of the measuring insert of the sensor

for temperature points within the range from -70 to 250°C:
 200 mm (min. 160 mm)
 for temperature points over 250°C: 300 mm (min. 260 mm)

The distance of the flange of the measuring insert from the medium level in the calibration bath shall be at least 40 mm at temperatures up to 250°C and min. 70 mm at temperatures over 250°C.

Temperature response time pursuant to EN 60751 in whirling water

for tube \varnothing 14 mm (characteristic value): $\tau_{0.5}$ 75 s
 $\tau_{0.9}$ 90 s
 for tube \varnothing 22 mm (characteristic value): $\tau_{0.5}$ 90 s
 $\tau_{0.9}$ 370 s

RELIABILITY

Indicators of reliability in operation conditions and ambient conditions specified herein

- Medium time of operation between failures 96 000 hours (inf. value)

Expected service life 10 years

DESIGNATION:

Data on head label

- Trademark of the manufacturer
- Made in Czech Republic
- Type of resistance sensor, nominal value R_0 / tolerance class / configuration of wires of internal wiring *)
- Measuring range or set-up converter range

- Product ordering number
- Ingress Protection
- Serial number
- Output signal 4 to 20 mA (design with converter)
- Ambient temperature
- Designation of non-explosiveness for sensor with metal protective tube:

⊕ II 1/2 G Ex db IIC T1...T6 Ga/Gb
 ⊕ II 1/2 D Ex ta/tb IIIC T=T media Da/Db
 ⊕ II 1 G Ex ia IIC T5/T6 Ga

- and number of EC Type Examination Certificate
- Designation of non-explosiveness for sensor with ceramic protective tube:

⊕ II 2 G Ex db IIC T1...T6 Gb
 ⊕ II 2 D Ex ta/tb IIIC T=T media Db
 ⊕ II 1 G Ex ia IIC T5/T6 Ga

- and number of EC Type Examination Certificate
- Designation of non-explosiveness and No. of EU Type Examination Certificate (for Ex ia design)
- CE mark 1026
- Other data for design /M1, /M2, /M3 a /M4
- Evaluation certificate. No ZR 141/10-

*) Configuration of wires of internal wiring is not specified for the converter

Data on measuring insert label

- Trademark
- Type of sensor, nominal value R_0 / tolerance class / configuration of wires of internal wiring *)
- Serial number
- Resistance value of internal wiring (for design without converter)

*) Configuration of wires of internal wiring is not specified for the converter

Data on converter label

- Trade mark
- Type of sensor
- Pre-set temperature range
- Designation of non-explosiveness and number of the EU-Type Examination Certificate - for converter Ex ia
- the conformity marking CE (for converter Ex ia with the number of the notified person)

Data on display

- Trade mark
- the conformity marking CE

DELIVERY

Unless agreed otherwise with the customer, each delivery includes

- Delivery note
- Sensor pursuant to the purchase order
- Allen key 1.5 mm
- Separately ordered accessories pursuant to the catalogue of accessories, type 991:
 - o Connecting flange or nipple with threaded ring, an instruction sheet is delivered with each nipple with threaded ring
 - o Suitable cable gland, an instruction sheet is delivered with each cable gland
- Optional accessories to sensor with programmable converter
 - o Configuration (parameterization) programme pursuant to the required converter
 - o Communication modem (for serial port RS 232C) pursuant to the required converter
- Accompanying technical documentation in Czech
 - o Product manual
 - o Product quality and completeness certificate, which also serves as the warranty certificate
 - o EU Declaration of Conformity
 - o EU Declaration of Conformity for Conformity with Metrological Compliance (/ M5)

If it is established in the purchase contract or agreed otherwise, the following documentation can be also delivered with the product

- Copy of the Inspection Certificate 3.1 for material of protective tube with the heat number
- Declaration of Conformity with purchase order 2.1 acc. to EN 10204
- Calibration sheet (for uncertified calibrated design)
- Copy of EU-Type Examination Certificate pursuant to the Directive No 2014/34/EU (for Ex ia design)

- Copy of EU-Type Examination Certificate
- Copy of Evaluation certificate for design /M1, /M2, /M3 and /M4
- Test report about the seismic and the vibration qualification

CERTIFICATION

- Non-explosiveness Ex ia, EU-Type Examination Certificate pursuant to the Directive 2014/34/EU. FTZÚ 08 ATEX 0200X as amended
- Non-explosiveness Ex ia, EU-Type Examination Certificate pursuant to the Directive 2014/34/EU FTZÚ 21 ATEX 0007X
- Non-explosiveness Ex ia, EU-Type Examination Certificate pursuant to the 2014/34/EU (pursuant to the type of the converter and display)
- Evaluation certificate. No. ZR 114/10-0068

CALIBRATION

It is realized pursuant to TPM 3342-94 and in compliance with EN 60751, usually in three temperature points spread evenly within the operation range of the sensor or in the points according to the requirement of the customer. Calibration sheets with measured data are issued for calibrated sensors.

ASSESSMENT OF CONFORMITY PURSUANT TO THE DIRECTIVE 2014/32 EU

Couple sensors are verified pursuant to EN 1434-5.

The sensors are rated products pursuant to the Directive 2014/32 EU of the European Parliament and the Council and EU Declaration of Conformity is issued for them.

The manufacturer performs subsequent verification under EN 1434-5. Subsequent verification is ordered in the department AMS ZPA N. Paka a.s. (ams@zpanp.cz). For subsequent verification, send the whole couple tied together.

METHOD OF PLACING THE MARK OF ASSEMBLY AND SERVICE ORGANIZATION AND REINSURANCE MARKS

Verified sensors have a self-adhesive label with reinsurance mark. The label is stuck on the terminal board and the sensor head.

After installation on place of use the sensors will be reassured with mounting seal eventually with label, preventing unauthorized manipulation.

After subsequent verification, the sensors will be provided with a self-adhesive label with an official mark. The label will be stuck on the terminal board and the sensor head instead of the original reinsurance mark.

PLACING THE MARK OF ASSEMBLY AND SERVICE ORGANIZATION AND REINSURANCE MARKS

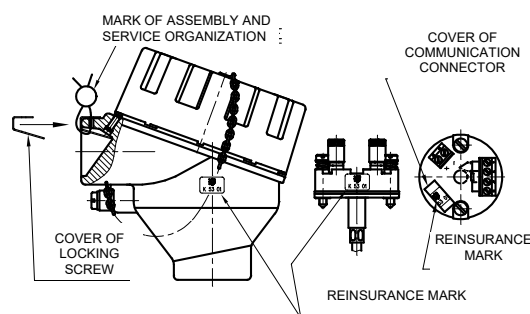

PACKING

Both sensors and accessories are delivered in a packing ensuring resistance to the impact of thermal effects and mechanical effects pursuant to controlled packing regulations.

TRANSPORT

The sensors may be transported on conditions corresponding to the set of combinations of classes IE 21 pursuant to EN IEC 60721-3-2 (i.e. by airplanes and trucks, in premises that are ventilated and protected against atmospheric effects).

STORAGE

The sensors may be stored on conditions corresponding to the set of combinations of classes IE 12 pursuant to EN IEC 60721-3-1 but with ambient temperature between -20 and 70 °C (i.e. in places where temperature and humidity are not controlled, with a threat of condensation, dripping water and formation of ice, without a special threat of an attack with biological agents, with vibrations of small significance and not situated close to sources of dust and sand.)

ORDERING TEMPERATURE SENSORS

The purchase order shall specify

- Name
- Product ordering number
- Ex ia design is ordered using codes J4X, D2X or D3X according to table 1
- Additional requirements for sensor design according to Table 2
- Request for additional documentation according to the Table 2
- Measuring range
- If calibration is required and in what temperature points
- If as sparely ordered accessories by type 991 the connecting flange or nipple with threaded ring is required to supply
- If optional accessories to the sensor with programmable converter is required
- Other (special) requirements
- Number of pieces

Behind the ordering number specified pursuant to Table 1, the customer shall identify the required range of measured temperature (i.e. so-called lower and upper temperature limits in °C) and, as the case may be, other non-standard required parameters for converter configuration (e.g. indication of sensor tripping, dampening, required designation - tagging etc.).

PURCHASE ORDER EXAMPLE

Standard design:

Resistance temperature sensor Ex d (Ex t) with metal protective tube without converter
252401 112 1B/J4/Q1
Calibration points 100, 250 a 400°C
Range -70 to 450°C
6 pcs

Special requirement:

Resistance temperature sensor Ex d (Ex t) with metal protective tube without converter
252 901 122 1B/18/2.1
Nominal length L 380 mm
Range 0 to 100°C
6 pcs

ORDERING ACCESSORIES

The purchase order shall specify:

- Name
- Product ordering number
- Number of pieces

PURCHASE ORDER EXAMPLE

Connecting flange
991 UP 14
5 pcs

TABLE 1 - DESIGN OF TEMPERATURE SENSORS WITH PROTECTIVE TUBE, TYPE 252

SPECIFICATIONS					ORDERING NUMBER																					
					252	x	x	x	x	x	x	x	x	x	/xxxxxxx	/xxx										
Nominal length L [mm]	350	Length of measuring insert L _{mv} [mm]	375	Length L1 [mm]	200	1																				
	500		525			2																				
	710		735			3																				
	800		825		400	4																				
	1000		1025			5																				
	1400		1425			6																				
	1600		1625			7																				
	2000		2025			8																				
	Other (max. 3000, ceramic tube max. 1600) *						9																			
Extension length	Without extension					0																				
Material of protective tube	1.4845 or 1.4841	maximum measuring range of the sensor		-70 to 450 °C ***)																1						
	1.4541 ****)																			2						
	1.4749 (only for Ø 22 mm)																			3	2					
	LUNIT 73 *)																			6	5					
	LUXAL 203 *)																			7	5					
Other *) **)	9																									
External ø of protective tube [mm]	14																				1					
	22																				2					
	22 cantilevered metal tube, 15 ceramic tube																				6 7					
Head of the sensor with thread for gland Ex d (Ex t) - overview of glands see Tab.4	Aluminium alloy painted with blue epoxy colour		M20x1.5																		1					
			1/2-14NPT																			2				
	Corrosion-resistant steel 1.4401		M20x1.5																			3				
			1/2-14NPT																				4			
Measuring insert tube for sensor with protective tube																						2				
Measuring resistor (sensing probe)	Pt100	maximum measuring range [°C]		-70 to 600																	1					
	Pt 500 *)																				2					
	Pt100 (only tolerance class B)																				8	B				
Tolerance class	A guaranteed only within range to 300°C																					1				
	B																						2			
Connection of terminal board	Single - four-wire (1xPt/ /4)																						/J4			
	Double - two-wire (2xPt/B/2)																						B	/D2		
	Double - three-wire (2xPt/ 3)																							/D3		
	Single – four-wire		only for Pt 100, with measuring insert																					1	/J4X	
	Double – two-wire		ø 6, length of measuring insert																					1	B	/D2X
	Double – three-wire		L _{mv} 100 – 3025 [mm]																					1	/D3X	

TABLE 1 - DESIGN OF TEMPERATURE SENSORS WITH PROTECTIVE TUBE, TYPE 252 (continuation)

SPECIFICATIONS						ORDERING NUMBER																		
						252	x	x	x	x	x	x	x	x	x	x	x	/xxxxxx	/xxx					
Converter (connection for converter: single, double, three or four-wire, pursuant to the converter)	Converter type	Galvanic separation	Ex ia	NFC	Range [°C]																			
	Analogue	INPAL 420				-50 to 50														/07				
						-30 to 70															/55			
						0 to 50																/15		
						0 to 100																	/18	
						0 to 150																		/19
						0 to 200																		/20
						0 to 250																		/21
						0 to 400														/23				
	Programmable	TH 100				Programmable range														/TH100				
		TH 100-ex		•																	/TH100X			
		TH 200	•																		/TH200			
		TH 200-ex	•	•																	/TH200X			
		IPAQ-H	•																		/IPAQH			
		IPAQ-HX	•	•																	/IPAQHx			
		MINIPAQ-HLP																			/MINIPAQ			
		APAQ C130			•																/C130			
		IPAQ C202																			/C202			
		IPAQ C202X			•																/C202			
	IPAQ C330	•																		/C330				
	IPAQ C330X	•	•																	/C330X				
	HART protocol	IPAQ C520	•																		/C520			
		IPAQ C520S *****)	•																		/C520S			
		IPAQ C520X	•	•																	/C520X			
		IPAQ C520XS *****)	•	•																	/C520XS			
		IPAQ C530	•		•																/C530			
		IPAQ C530X	•	•	•															/C530X				
		TH 300	•																	/TH300				
		TH 300-ex	•	•																/TH300X				
		MESO-H	•																	/MESOH				
		MESO-HX	•	•																/MESOHx				
	248 HA NA	•																	/248HANA					
	248 HA I1	•	•																/248HAI1X					
	644 HA NA	•																	/644HANA					
644 HA I1	•	•											5						/644HAI1X					
Other *)																			/99					
Without converter (for installation of the converter by the customer - simple four-wire connection)																			/00					
LED display to loop 4-20 mA (not possible with head from corrosion resistant steel) (only with converter INPAL 420, TH 100, MINIPAQ-HLP)					LPI-02														/LD					
Special design for negative temperatures -196°C *)																			/CT					

Standard design

- *) Only as a special requirement after an agreement with the manufacturer
- **) For Zone 0, a thermowell from corrosion-resistant alloy shall be used (pursuant to EN 60079-26)
- ***) Up to 600°C in case of a type of installation pursuant to Figure 5 (not for measuring resistor with tolerance class A)
- ****) Protective tubes of this material are suitable for contact with food
- *****) Functional safety SIL2

TABLE 2 – ADDITIONAL REQUIREMENT FOR DESIGN OF TEMPERATURE SENSORS WITH PROTECTIVE TUBE, TYPE 252

SPECIFICATIONS				CODE	
CALIBRATION (for sensors as described below)	DESIGN OF TEMPERATURE SENSORS	MEASURING RANGE [°C]		USE	
Calibration by TPM 3342-94, in three calibration points evenly distributed in the sensor measuring range for use as part of the customer's measurement assemblies pursuant to Directive No. 2014/32/EU (MID), Annex MI-002 and MI-005 *)	sensors with metal protective tube, unpaired, without converter in connection 1xPt100/..J4 min. length of measuring insert for temperature to 250°C 210 mm for temperature over 250°C 275 mm	-50 to 50		application for residential and business premises and for the light industry	/M1
		-50 to 100			/M2
		0 to 200			/M3
		0 to 300	for sensor with measuring resistance in tolerance class A		/M4
0 to 400	for sensors with measuring resistance in tolerance class B				
CALIBRATION	NUMBER OF CALIBRATION POINTS	CALIBRATION RANGE			
Calibration by TPM 3342-94, define calibration points	3	0 to 420 °C		/Q1	
	3	0 to 600 °C		/Q2	
	3	-196 to 100 °C		/Q3	
	3	-50 to 600 °C		/Q22	
	Other	-50 to 600 °C		/Q9	
REQUIREMENT FOR OTHER DOCUMENTATION			USE		
Copy of Evaluation certificate No. ZR 141/10-0068			M1, M2, M3, and M4		
EU Declaration of Conformity			for design with converter		
Copy of EU-Type Examination Certificate acc to the 2014/34/EU			for fixed closure and a dust-tight closure		
Copy of EU-Type Examination Certificate acc to the 2014/34/EU (ATEX)			for Ex ia design		
Copy of the Inspection Certificate 3.1 acc to EN 10204 for material of protective tube with the heat number			/3.1		
Declaration of Conformity with purchase order 2.1 pursuant to EN 10204			/2.1		

Specify the code behind ordering number. Define calibration points for codes Q1, Q2, Q3, Q22 and Q9.

*) only as a special request after an agreement with the manufacturer

TABLE 3 - ACCESSORIES - OVERVIEW OF DESIGNS RECOMMENDED FLANGES AND NIPPLES (to be ordered separately)

SPECIFICATIONS		ORDERING NUMBER
Connecting flange	for protective tube Ø 14 mm	991 UP 14
	for protective tube Ø 22 mm or cantilevered metal tube of ceramic tube Ø 15 mm	991 UP 22
Nipple with threaded ring for protective tube Ø 14 mm	Material	carbon steel 1.0122
		stainless steel 1.4541
Nipple with threaded ring for protective tube Ø 22 mm or cantilevered metal tube of ceramic tube Ø 15 mm	Material	carbon steel 1.0122
		stainless steel 1.4541

TABLE 4 - OVERVIEW OF DESIGNS AND ORDERING OF CABLE GLANDS Ex d (Ex t) BRASS – TYPE 991

SPECIFICATION								Ordering number		
Gland Ex d (Ex t) brass		Cable clamp (clamping module)			Thread	Torque of gland body	For cable Ø [mm]	991	xx	xxx
Size	Wrench		Size	Dimension						
	A	B		C	Ds					
No. 4	OK 17	OK 24	No. 4	5	20	M20×1.5	30 - 35 Nm	4,5-8.5	VM	458
No. 5	OK 19		No. 5	5	22			7-11	VM	711
No. 6	OK 24		No. 6	6	27.5			10-16	VM	016
No. 4	OK 17		No. 4	5	20	1/2-14 NPT	25 - 30 Nm	4,5-8.5	VK	458
No. 5	OK 19		No. 5	5	22			7-11	VK	711
No. 6	OK 24		No. 6	6	27.5			10-15.5	VK	015

INSTALLATION AND CONNECTION

SENSOR INSTALLATION

The sensor installation is realized by means of a connecting flange or by means of a nipple with a threaded ring.

SENSOR WITH METAL PROTECTIVE TUBE INSTALLATION



WARNING

The metal protective tube of temperature sensor may be install to the thermowell located in the zone 0 (20), zone 1 (1) or zone 2 (22).

The other parts of the sensor (fitting, adapter, connecting head) may be located in zone 1 (21) or zone 2 (22).

When installing sensor in the thermowell located in zone 20, a pre-fuse with the following parameters must be used in the converter encoder circuit: Ceramic, quick break (F), short circuit resistance 1500A (H), e.g. ceramic tube fuse Ø5 x 20 mm, F100mA.



Distance of the fixed closure Ex d IIC from close structures or between the closures shall be at least 40 mm.

The temperature sensor with a paint finish must be installed in an explosive atmosphere with dust so as to avoid the occurrence of creep discharges

SENSOR WITH CERAMIC PROTECTIVE TUBE INSTALLATION



WARNING

Fix sensor to the cantilevered metal tube!

Install the sensor so that the cement joint is out of reach of high temperatures due to the different thermal expansion of the cantilevered metal tube and the ceramic protective tube.

When installing or changing the sensors during operation, slide them in and out of the high-temperature environment gradually (about 20 mm in 1 minute) to avoid rupture ceramic protective tubes due to thermal stress caused by a rapid temperature change.

If slow sensor movement is not possible, ensure at least its slow and even preheating.

**WARNING**

The ceramic protective tube of temperature sensor may be install to the thermowell located in the zone 0 (20), zone 1 (1) or zone 2 (22).

The other parts of the sensor (fitting, adapter, connecting head) may be located in zone 1 (21) or zone 2 (22).

Distance of the fixed closure Ex d IIC from close structures or between the closures shall be at least 40 mm.

FLANGE INSTALLATION

Weld the bottom part of the flange into the wall of the technological equipment. In the connecting flange, you can move the sensor after releasing two screws M6x14, whereby you can achieve the required immersion of the sensor.

CONNECTING FLANGE 991 UP 14 A 991 UP 22

(quotation for 991 UP 22 in parentheses)

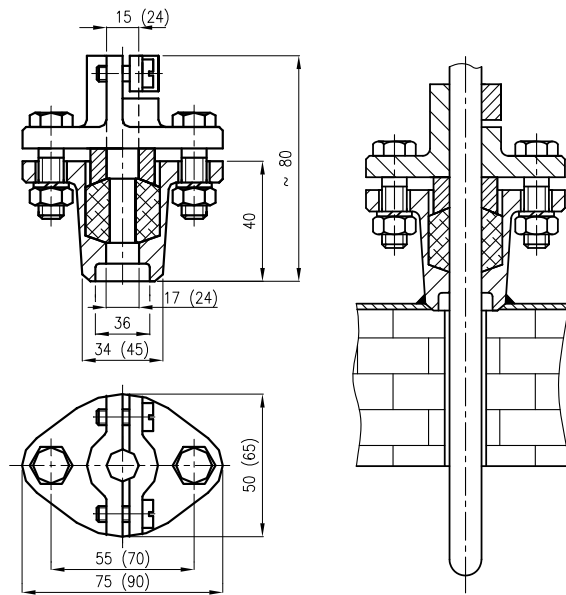

INSTALLATION OF THE NIPPLE WITH THREADED RING SHALL BE REALIZED PURSUANT TO THE INSTRUCTION LABEL AS FOLLOWS:

- 1) Uninstall the complete nipple by unscrewing the cap nut
- 2) Weld the nipple itself (after possible shortening) onto the wall of the piping or another technological equipment
- 3) On the metal protective tube of the rod temperature sensor, put the cap nut, thrust ring and threaded ring in the said order,
- 4) Slide the temperature sensor with put-on components pursuant to point 3 into the prepared nipple and only tighten it adequately after the definitive selection of immersion (recommended torque is 60 to 70 Nm).

**WARNING**

Length of the immersion part of the sensor cannot be changed repeatedly; the sensor can only be uninstalled!

With respect to maintaining metrological properties and the longest possible service life, it is not recommended to install the sensors in places with high turbulence of the medium, which is caused e.g. by a rapid transition from a small diameter of the piping to a larger one (when failing to comply with the required shape and dimensions of diffuser behind the flow meter), etc. Recommended distance of the temperature sensor from the installation flange of the flow meter is min. 1 m.

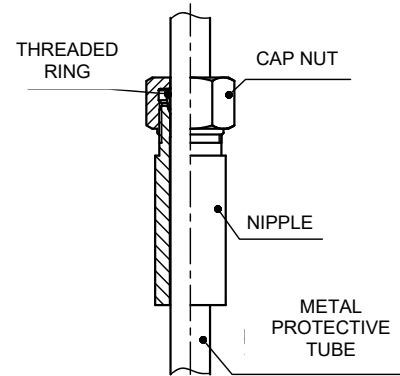
NIPPLE WITH THREADED RING**INSTALLATION OF CABLE GLAND**

To secure the fixed and dust-tight closure, only the certified cable gland Ex d IIC (Ex tb IIIC) with Ingress protection IP 68 shall be used (refer to accessories 991 or another similar gland). For temperature sensors with converter, a barrier cable gland must be used in zone 1 of the IIC gas group or an Ex ia converter must be used. It shall be tightened in the sensor head in the prescribed way.

Torque of gland body:

- a) for gland with thread 1/2 - 14NPT 25 – 30Nm
- b) for gland with thread M20x1.5 30 – 35Nm

Installation of the cable in the gland, its sealing and securing against pull-out shall be realized pursuant to the instruction sheet of the gland supplier.

**WARNING**

Do not use other sealing rings in the gland than the original ones delivered by the manufacturer. Do not change artificially the outer diameter of the cable e.g. by winding it around with electrical insulating tapes.

ELECTRICAL CONNECTION

The electrical connection may be only realized by qualified workers pursuant.

The sensor installation in conditions with explosive gaseous atmosphere or flammable dust shall comply with the requirements of EN 60079-14.

The terminal board of the sensor (converter) is accessible after tilting away the lid of the head, which is connected with one screw.

Connect the evaluation devices to the sensor with a non-armoured cable with double insulation with outer diameter 5 to 8 mm (internal wires with Cu core with cross section 0.5 to 1.5 mm²). Seal the cable outlet of the sensor adequately.

**WARNING**

Do not use independent wires without jacket for electrical connection. To ensure the Ingress Protection grade in the outlet, the connecting cable shall have circular cross-section. Temperature resistance of the cable shall comply with the ambient temperature

The cable insulation shall have chemical and mechanical resistances in compliance with the conditions, in which the cable will be installed. It is recommended supporting the cable along its length between the sensor and the follow-up device. In the environment with interfering signals, use shielded cable in the power supply circuit. Shielding may be only grounded (earthed) in one point. The cable should not be placed together with power cables.

In case of the sensor with HART protocol converter, the maximum length of wiring is defined by the arrangement of wires of the connecting cable. The total length of wiring may be up to 1500 m. It requires a twisted two-wire with shared shielding with the diameter of the cross section of the core min. 0.5 mm². The HART communicator is connected to the supply loop of the sensor with converter pursuant to Figure 2. To achieve reliable communication, the total load resistance of min. 250 Ω shall be in the circuit of the output loop.

**WARNING**

Programmable converter may not be connected to a computer or a HART communicator, if the converter is located in explosive environment.



The surface temperature of the converter must not exceed the maximum surface temperature for a given temperature class.

For installation in a dangerous area, a connection is required (placing on the same potential). You can use the terminals on the sensor head to do this.

The sensor need not be connected separately to the interconnection system if it is firmly attached and metallically connected to the components or piping that is connected to the interconnection system.

SENSOR HEAD WITH TERMINALS

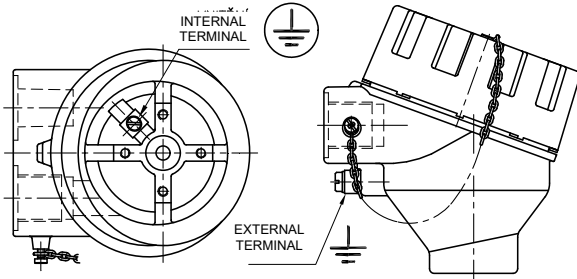

Maximum cross-section of wire for connection to external and internal clamps:

Internal clamp: stranded wire 1.5 mm², full wire 2.5 mm²
 External clamp: stranded wire 4.0 mm², full wire 6.0 mm²
 If stranded wires are used for the interconnection, they shall be protected against fraying with pressing hollow.

CLOSING HEAD OF FIXED CLOSURE Ex d

After electrical connection of the sensor, the lid of the head shall be fully tightened by hand, then released slightly to ensure matching with the closest groove against the securing pin and fixed by this screw against releasing. If the lid of the sensor is not tightened and secured with the above mentioned screw, the sensor does not comply with the requirements of fixed closure Ex d.

WARNING: Ex
Electric supply of the sensor may not be connected before closing the fixed closure!

SENSOR INSTALLATION WITHOUT CONVERTER AND SENSOR WITH CONVERTER Ex ia TO ZONE 0 (20)

WARNING: Ex
The user is responsible for ensuring that during operation in zone 0 is between the sensor head from an aluminium alloy and other equipment preclude any risk of ignition due to impact and friction.

The sensor without converter can be used, in case of the installation pursuant to EN 60079-11, Art. 5.7 in the intrinsically safe circuit Ex ia according to EN 60079-25), as a simple equipment. For simple equipment, the maximum temperature can be determined from the value of the P₀ of the follower and the temperature class is determined.

Sensor with converter Ex ia can be used while adhering to the Ex ia parameters of the converter shall be complied with pursuant to the enclosed converter manual.

In intrinsically safe circuits, only insulated cables that are capable of withstanding an electrical strength test with a voltage equal to twice the voltage in the intrinsically safe circuit or 500 V eff (DC 750 V) must be used, with a larger value being taken.

When installing intrinsically safe circuits, including cables, do not exceed the maximum allowable inductance, capacity or ratio LiR and surface temperature. Permissible values are determined from the documentation of the connecting device or label. Place follow-up equipment out of the danger area. An intrinsically safe source approved for supplying intrinsically safe devices in accordance with EN 60079-11 must always be used.

The shield of the intrinsically safe circuit cable must be grounded in the same place as the intrinsically safe circuit, the connection must be outside the dangerous area.

If the intrinsically safe circuit is isolated from the ground, the shield must be connected in one place to the protective

interconnection system. This can be using the terminals on the sensor head.

COMMISSIONING

After the installation of the sensor, including closing the fixed closure and connection of the follow-up (evaluation) device to the supply voltage (and the settlement period of the converter), the equipment is prepared for operation.

WARNING: Ex
After finish installation of the sensor in the environment with explosive gaseous atmosphere the default device revision and installation must be performed in EN 60079-17.

OPERATION AND MAINTENANCE

The sensor does not require any operation; maintenance and follow-up regular periodic revisions or permanent supervision of expert staff shall be realized pursuant to ČSN EN 60079-17.

WARNING: Ex
Any intervention into the sensor and its structure will result in a change of properties and can result in an explosion!

SENSOR UNINSTALLATION

WARNING: Ex
Temperature sensor is in design Ex and must be disconnected from the power supply source before opening the lid of the head and releasing the cable gland in the explosive environment!

Then release the securing screw of the lid with ALLEN key 1.5 mm (a part of accessories). The terminal board of the sensor (converter) is accessible after unscrewing the lid of the head. Measuring insert of the sensor can be replaced and is uninstalled from the head after disconnecting the cable by releasing two screws.

Before a complete uninstallation of the sensor, the wire for mutual interconnection shall be released from the external clamp or the internal clamp on the sensor.

Disconnect the connecting cable from the terminal board; then release it from the clamp on the gland and from closing nut of the gland. Unscrew the sensor from the thermowell; torque for releasing is approx. 70 Nm. While releasing the screw union of the sensor, the thermowell may never be released.

REPAIRS

The sensors shall be repaired by the manufacturer. They shall be sent for repair in the original or equal package without accessories.

SPARE PARTS

Spare parts shall be delivered by the manufacturer. Relevant measuring inserts can be ordered pursuant to the following table:

SPECIFICATION	ORDERING NUMBER					
	MV250	/xxx/	1	x	x	/xxxx
Length of measuring insert [mm]		pursuant to tab. 1	1			
External Ø protective tube [mm]	22		1			
	14		2			
Sensing probe	Pt100 (600°C)			1		
	Pt500 (600°C)			2		
	Pt100 (800°C)			8	B	
Tolerance class	A				A	
	B				B	
Connection of terminal board or converter	Pt100/ /4					/J4
	2xPt100/B/2				B	/D2
	2xPt100/ /3					/D3
	Pt/ /4 *)			1		/J4X
	2xPt/B/2 *)			1	B	/D2X
	2xPt/ /3 *)			1		/D3X
Pt/ /4C						/J2S
Converter pursuant to tab. 1						/converter

*) Ex ia design

PURCHASE ORDER EXAMPLE OF MEASURING INSERT

Resistance measuring insert without converter
 250 /735/ 21B/J4
 6 pcs

To order the certified measuring inserts, specify the code according to Table 2 – Additional requirements – behind the ordering number.

The measuring inserts are marked according to Article DESIGNATION. Designation is completed with the ordering number.

Each delivery includes

- Delivery note
- Measuring insert pursuant to the purchase order
- Optional accessories to the measuring insert with a programmable converter
 - o Configuration program according to the required converter
 - o Communication modem (for serial port RS 232C) according to the required converter
- Accompanying technical documentation in Czech
 - o Product manual
 - o Product quality and completeness certificate, which also serves as the warranty certificate
 - o EU Declaration of Conformity (for Ex ia design)

If it is established in the purchase contract or agreed otherwise, the following documentation can be also delivered with the product

- Calibration sheet (for calibrated design)
- EU Declaration of Conformity (for design with converter)
- Copy of EU-Type Examination Certificate pursuant to the Directive No 2014/34/EU for Ex ia design

WARRANTY

The warranty period is 24 months from the receiving of the product by the customer, unless established otherwise in the contract. Rejection of defects shall be enforced in writing at the manufacturer within the warranty period. The rejecting side shall identify the product name, ordering and manufacturing numbers, date of issue and number of the delivery note, clear description of the occurring defect and the subject of the claim. If the rejecting side is invited to send the device for repair, it shall do so in the original package of the manufacturer and/or in another package ensuring safe transport.

The warranty shall not apply to defects caused by unauthorized intervention into the device, its forced mechanical damage or failure to comply with operation conditions of the product and the product manual.

DISABLING AND LIQUIDATION

The product and its package do not include any parts that could impact the environment.

Products that are withdrawn from operation, including their packages (with the exception of products marked as electrical equipment for the purposes of return withdrawal and separate salvage of electrical waste), may be disposed of to sorted or unsorted waste pursuant to the type of waste.

The manufacturer realizes free return withdrawal of marked electrical equipment (from 13.8.2005) from the consumer and points out the danger connected with their illegal disposal. The package of the sensor can be recycled completely. Metal parts of the products are recycled, non-recyclable plastic materials and electrical waste shall be disposed of in accordance with applicable legislation.

FIGURE 1 - SCHEME OF CONNECTION OF TEMPERATURE SENSORS

SCHEME OF CONNECTION WITHOUT CONVERTER

J4 - With simple measuring resistor in four-wire connection (Pt 100/ /4)

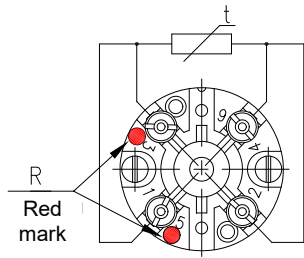

D2 - With double measuring resistor in two-wire connection ($2 \times \text{Pt } 100/\text{B}/2$)

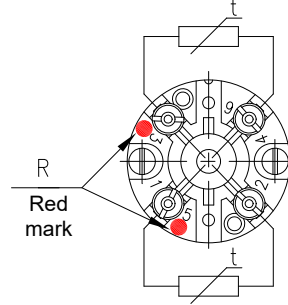

D3 - With double measuring resistor in three-wire connection ($2 \times \text{Pt } 100/ /3$)

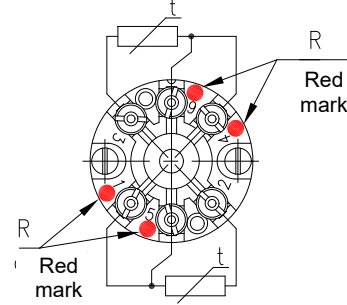

SCHEME OF CONNECTION WITH CONVERTER AND DISPLAY

with converter

with converter with HART protocol

with converter Ex ia with HART protocol

with converter Ex ia with HART protocol

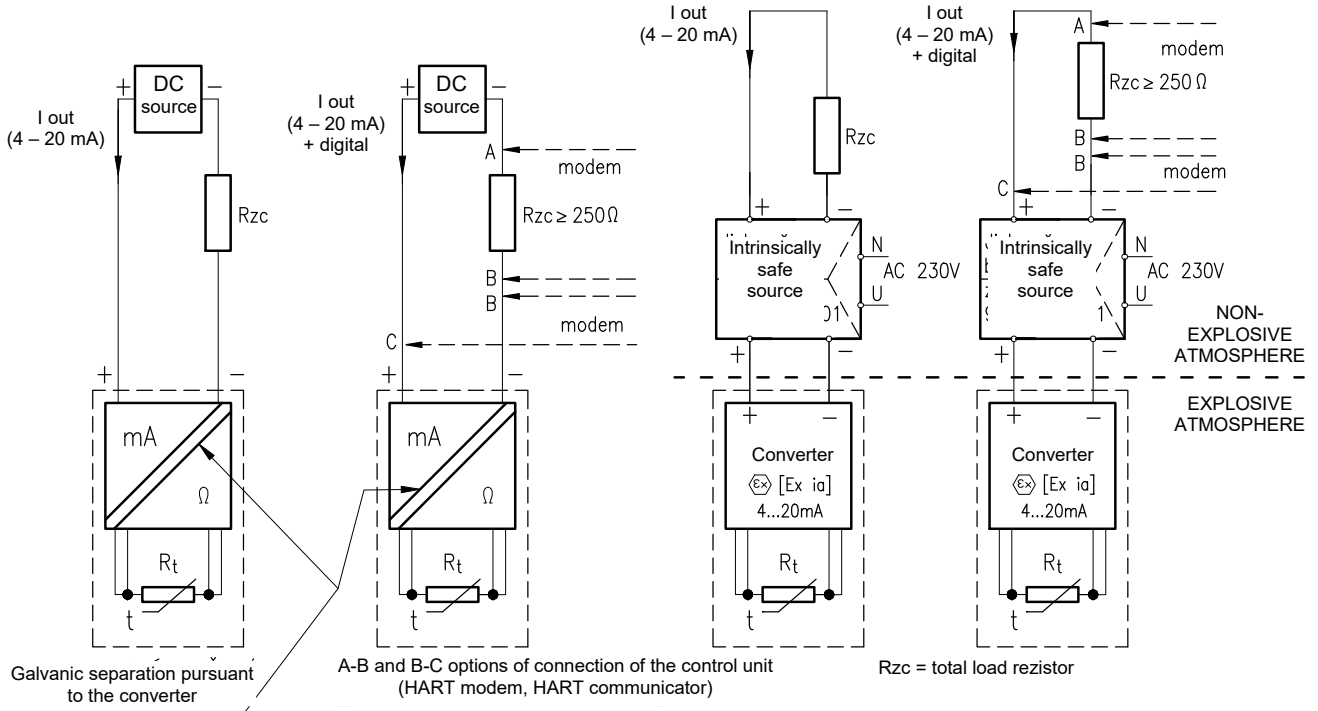

FIGURE 2 - EXAMPLE OF OPERATION CONNECTION OF TEMPERATURE SENSOR WITH CONVERTER IN LOOP 4 - 20 mA

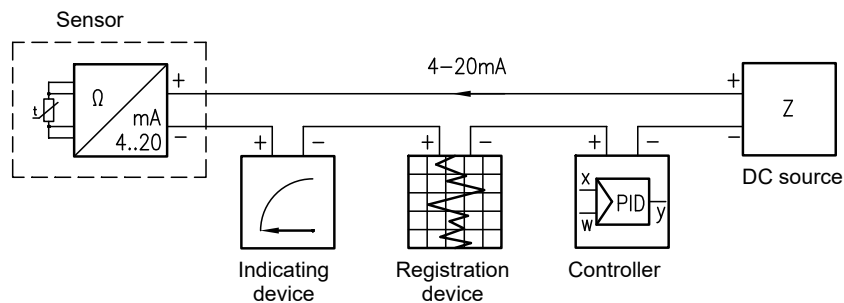
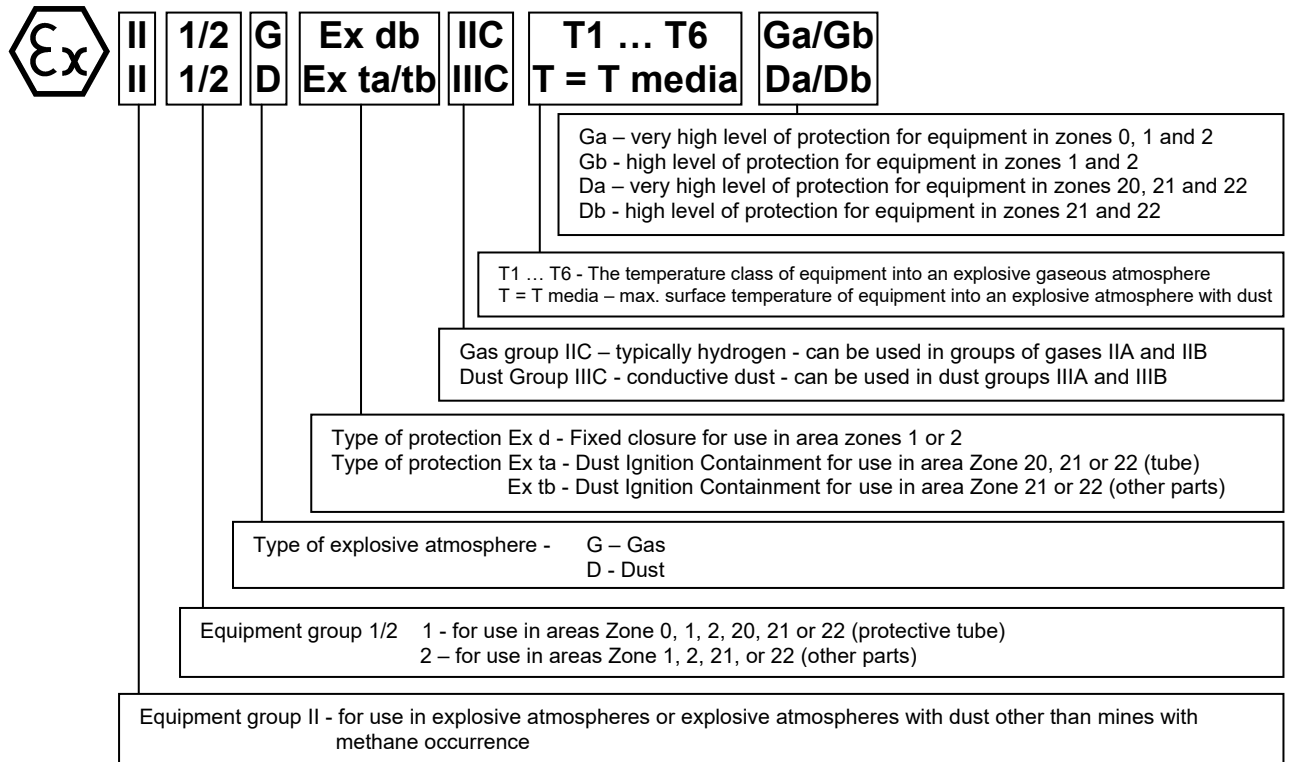

FIGURE 3 – MARK OF NON-EXPLOSIVENESS

for sensor with metal protective tube



for sensor with ceramic protective tube

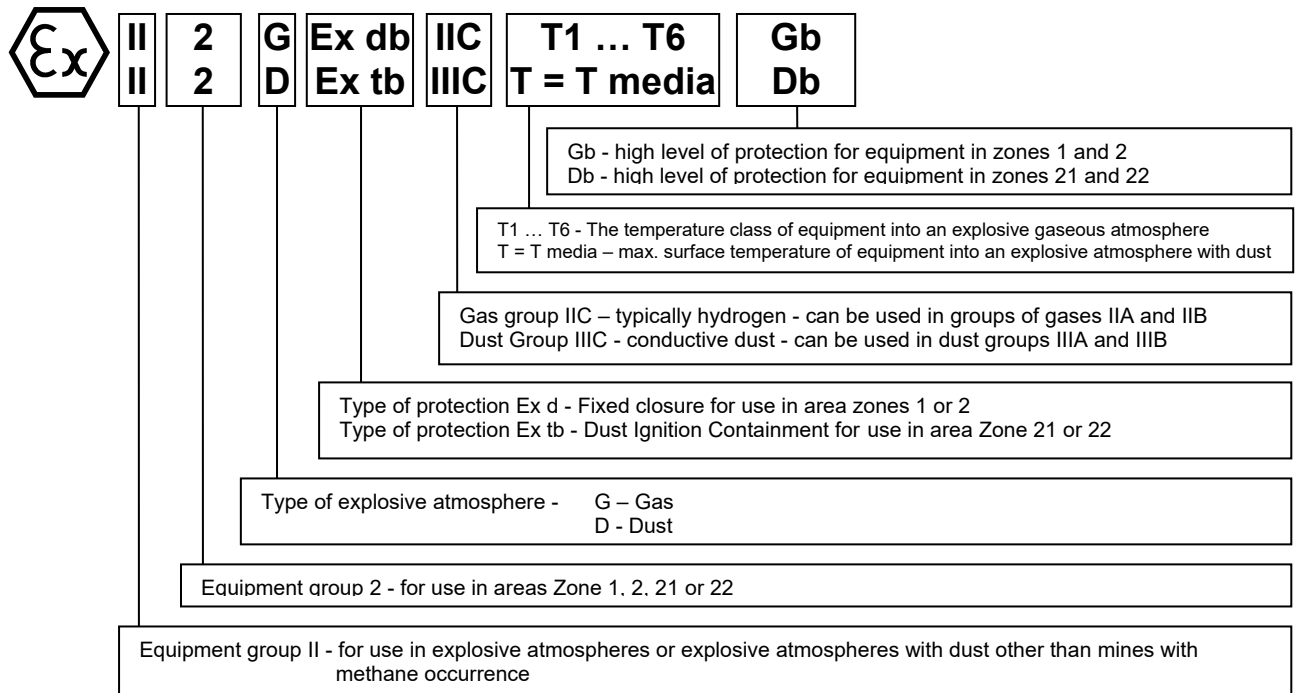

FIGURE 4 - INTRINSICALLY SAFE MARKING

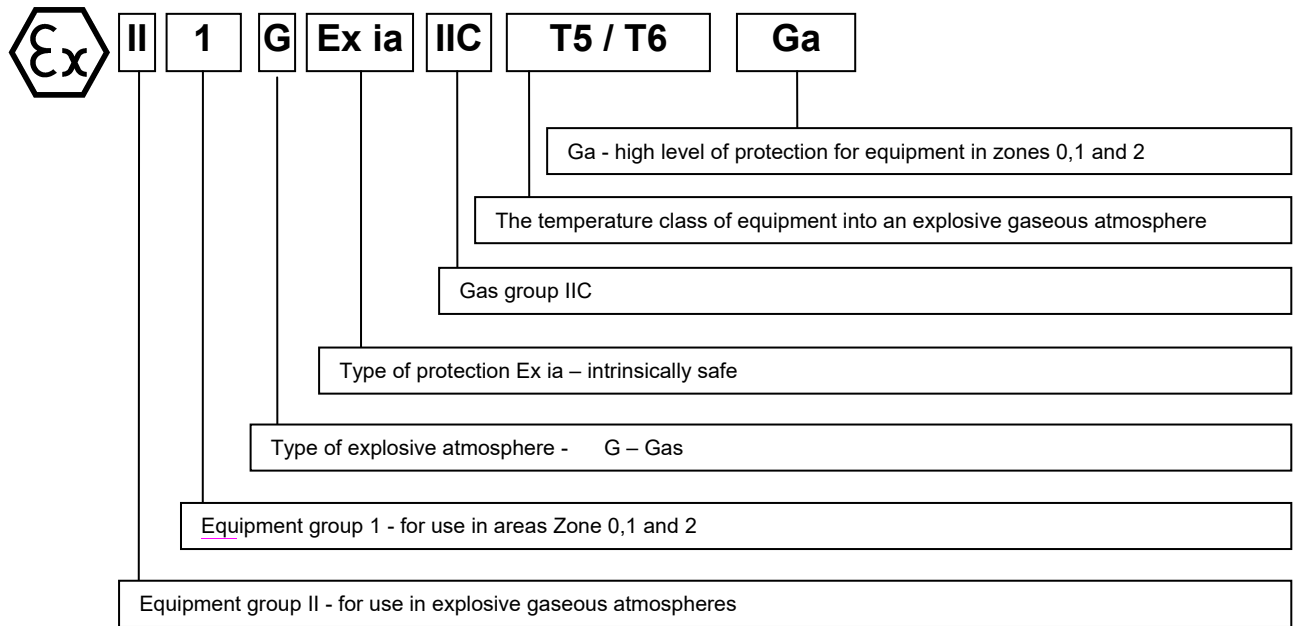
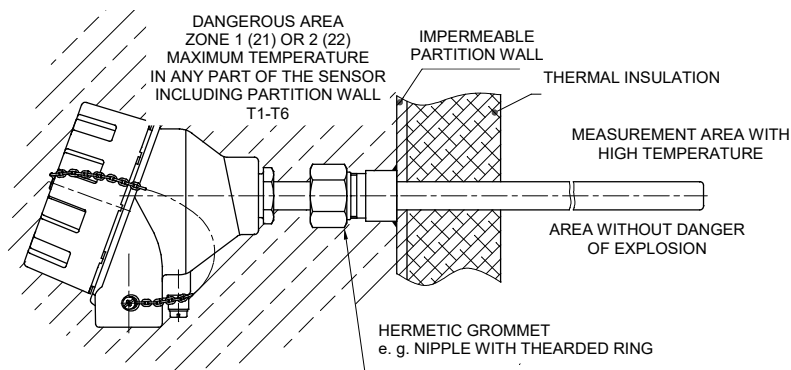

FIGURE 5 – EXAMPLE OF INSTALLATION OF TEMPERATURE SENSORS Ex d WITH METAL PROTECTIVE TUBE
(in case a higher limit of the measurement range is required on a level exceeding the required temperature class)



April 2021

© ZPA Nová Paka, a.s.



ZPA Nová Paka, a.s.
Pražská 470
509 01 Nová Paka

tel.: spojovatel: 493 761 111
e-mail: obchod@zpanp.cz
www.zpanp.cz

bankovní spojení: ČSOB HK
číslo účtu: 271 992 523/300

IČO: 46 50 48 26
DIČ: CZ46504826