



PRODUCT MANUAL

Electric pull-rod servomotor to 20 kN ZEPADYN 671 Type 671

APPLICATION

- Servomotors are designed for adjusting control elements (e.g. valves), for which their properties are suitable.

The servomotors are rated products pursuant to the Directive 2014/35EU, 2014/30/EU of the European Parliament and the Council and EU Declaration of Conformity **EU-660000** is issued for them.

DESCRIPTION

Servomotors are direct, pull-rod, with constant control speed of adjustment of the outlet part. The reversing asynchronous motor and self-locking gear mechanism are stored in the box with removable lid. Conductors are brought in through sealing outlets. The outlet pull-rod is ended with a coupling for connecting with a valve. The design is solved so that the connection elements can be attached pursuant to the design of the relevant valve (flange, columns, etc.).

The control can be ensured either with a three-point connection or position control, signal 0 to 1V, 0 to 10 V, 0 to 20 mA and 4 to 20 mA. It transfers the inlet analogue signal to the corresponding position of the servomotor. The position is sensed by the resistance transmitter. It can be completed with a sensor for checking maximum temperature of the motor, which trips it and activates signalling after the maximum pre-set value has been exceeded. The inlet signal can be changed with interconnected pieces, limit positions can be adjusted by means of push-buttons or by means of a computer. It can also be used for adjusting the upper and the lower insensitivity zones, changing the course of movement of the servomotor with respect to the inlet signal, type of operation of the controls in case of exceeding the adjusted range by 5 % (open, close, without response, movement to the end position in the direction of the signal).

In addition to strength switches, position indicators, thermal fuse of the driving motor and manual control, they can be equipped with:

- two signalling switches, adjustable within the whole range of the operation lift;
- resistance position transmitter 100 Ω (one or two);
- resistance position transmitter with signal converter 4 to 20 mA for two-wire connection to measuring loop (power supply directly from measured signal);
- capacity position transmitter CPT1 / A - signal 4 to 20 mA, double wire (power supply from auxiliary source);
- heating resistor.

PRINCIPLE

The engagement force is transmitted to the rod nut after compression of the plate spring column located between the ball bearings in which the nut is mounted. The force switches are actuated by moving the nut in the axial direction. When the tripping force is reached in both directions of the output drawbar movement throughout the working stroke, they are switched off.

The actuator rod stroke is determined by the valve operating stroke for the "OPEN" and "CLOSED" positions. The "OPEN" rod position must be defined by a stop outside the actuator, or a position microswitch can be used to switch off the drive motor.

The switching position of both position signaling switches is individually adjustable over the entire working stroke range.

TECHNICAL DATA

Device design:

- with AC 230 V supply pursuant to EN 61140 as an electrical protection class I, for use in networks with overvoltage category II and pollution level 2 pursuant to EN 61010-1
- with AC 24 V supply pursuant to EN 61140 as an electrical protection class I, for use in networks with overvoltage category III and pollution level 2 pursuant to EN 61010-1

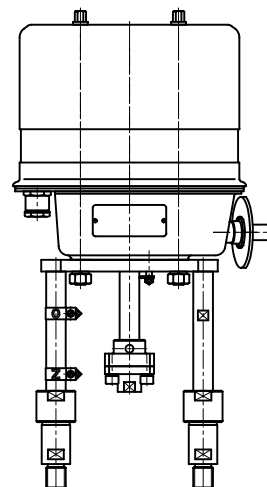

The servomotor has internal and external protective clamps, which are mutually interconnected.

The servomotor has no fuse of mains power supply and it shall be secured with an external fuse pursuant to EN 60127-2.

Electrical strength

Servomotor with supply voltage AC 230 V:

- Circuit of power supply and signalling switches against protective clamp: AC 1500 V
- Circuit of power supply and signalling switches against transmitter circuit: AC 2300 V
- Circuit of transmitter against protective clamp: AC 500 V

Servomotor with supply voltage AC 24 V:

- Circuit of power supply and signalling switches against transmitter circuit: AC 740 V
- Circuit of power supply and signalling switches against protective clamp: AC 500 V
- Circuit of transmitter against protective clamp: AC 500 V

Electrical insulation resistor: min. 20 M Ω

Power supply

Servomotor with supply voltage AC 230 V:

- Type of supply mains: 1/N/PE AC 230 V, 50 Hz
- Supply voltage tolerance: $\pm 10\%$
- Mains frequency tolerance: 48 to 52 Hz

Servomotor with supply voltage AC 24 V:

- Type of supply mains: AC 24 V, 50 Hz
- Supply voltage tolerance: $\pm 10\%$
- Mains frequency tolerance: 48 to 52 Hz

The motor is protected against overload with a thermal fuse, which trips after the temperature of approx. 130 ± 5 °C is reached.

Power input: max. 99 VA
heating resistance 15 W

Ingress Protection pursuant to EN 60529: IP 65

Operation position:

Discretionary, the position with vertical axis of the outlet shaft is considered the basic one. However, positioning below the controlled equipment is not recommended.

Sensor weight: approx. 12.5 kg

Type of operation: continuous

Applied materials:

Panel: steel sheet

Electrical connection:

Terminals: screw for wire cross section up to 1,5 mm²
Grommets: CAPRI newcap pa PG13
for cable diameter 6 to 12 mm

OPERATION CONDITIONS

The environment is defined by the group of parameters and their severity grades IE 36 pursuant to EN 60721-3-3 and the following operation conditions.

Ambient temperature: -25 to 55 °C
In the operation at temperatures below -15°C and in wet conditions, a resistor shall be connected, even if the servomotor is idle (code T1).

Relative ambient humidity:
10 to 100 % with condensation, with upper level of water content 29 g H₂O/kg of dry air

Atmospheric pressure: 70 to 106 kPa

Vibrations:

- Frequency range [Hz] 10 to 150
- Drift amplitude [mm] 0.15
- Acceleration amplitude [m.s⁻²] 20

Electromagnetic compatibility pursuant to EN 61326-1:

Values of interference voltage, on the network terminals in the band pursuant to EN 55011: class A, group 1

Electrostatic discharges, EN 61000-4-2:

4 kV contact, 8 kV by air, functional criterion B

External electromagnetic field, EN 61000-4-3:

10 V/m 80-1000 MHz, 80% AM 1kHz, functional criterion A

Fast transient phenomena, EN 61000-4-4:

2 kV power supply, 1 kV Sig. I/O, functional criterion B

Surge impulse EN 61000-4-5:

1 kV power supply symmetric and signal I/O, functional criterion B

2 kV power supply symmetric and signal, functional criterion B

Induced hf field pursuant to EN 61000-4-6:

3 V, 0.15 – 80 MHz, functional criterion A

Magnetic field of mains frequency, pursuant to EN 61000-4-8:

30 A /m, functional criterion A

Declines of power supply drops pursuant to EN 61000-4-11:

30 %, duration period 10 ms functional criterion A

60 %, duration period 100 ms functional criterion C

60 %, duration period 1000 ms functional criterion C

>95 %, duration period 5000 ms functional criterion C

METROLOGICAL DATA

Nominal strength and speed of adjustment of the output and uplift: see table 1

Accuracy of nominal strength: ± 10 %

Accuracy of output part changeover speed: ± 10 %.

Operation life of servomotor: min. 12 mm, max. 65 mm
Minimum and maximum operation lift is limited by the operation lift of the valve. Strength switches switch off when the pre-set value of strength is achieved at any position within the operation lift.

Tolerance of the output part with load 25 % of nominal strength: max. 0.3 mm

Time interval for reversing: min. 50 ms (without load)

Load factor: pursuant to EN 60034-1

- interrupted action S4 - 80 %, 100 to 1200 cycles / hour
- short-term action S2 - 60 minutes

Hysteresis of signalling switches: max. 3°

Rating of position switches and signalling switches:

AC 250 V / 5A resistance load
3A inductive load

Parameters of resistance transmitter (related to max. lift):

- total resistance 100 Ω ± 3 Ω
- residue resistance in position "C" max. 10 Ω
- residue resistance in position "O" max. 10 Ω
- non-linearity max. ± 1 %
- hysteresis max. 1 %
- rating max. 120 mA

Parameters of resistance transmitter with converter

4 to 20 mA (related to max. lift):

Power supply: DC 12 to 45 V from safe source PELV or SELV

Load resistor: Rz = (U-12)/0.02 [Ω]

Settlement period after switching on power supply: 30 min.

Output signal: 4 to 20 mA DC
20 to 4 mA DC

Ripple: max. 5 %
Non-linearity: max. ± 1 %
Hysteresis: max. 1 %

Parameters of capacity transmitter with converter (related to max. lift):

- output signal 4 to 20 mA (or 20 to 4 mA)
- non-linearity max. ± 1 %
- hysteresis max. 1 %
- rating max. 20 mA

- ripple max. 5 %
- power supply DC 15 to 28 V
- load resistor 500 Ω
- default set-up of transmitter sector 120°

Electronics has galvanic insulation from the case.

Parameters of position control (related to max. lift):

- power supply AC 230 V
AC 24 V
- inlet signal with maximum tolerance ± 5 %
It can be changed by means of interconnecting pieces refer to Article INSTALLATION AND CONNECTION, ADJUSTMENT OF POSITION CONTROL.
0 to 1 V / 10 kΩ
0 to 10 V / 100 kΩ
0 to 20 mA / 100 Ω
4 to 20 mA / 100 Ω
- outlet relay contact – 250 V, 1 A
- action in case of failure it goes to the end position in the direction of the signal (other possibilities: open, close, without response)
- switch-off time 150 s ± 10 % (2.5 min.) - possible adjustment 5 to 250 s
- operation restart after switching the device on and off
- upper insensitivity zone 2 % (possible adjustment 2 to 5 %)
- lower insensitivity zone 2 % (possible adjustment 2 to 5 %)
- course of movement linear

Possible modifications of parameters - refer to Article. INSTALLATION AND CONNECTION, ADJUSTMENT OF POSITION CONTROL.

DESIGNATION

Data on the servomotor label:

- Trade mark of the manufacturer
- Made in Czech Republic
- Product number
- Serial number
- Type of power supply
- Power input
- Adjustment speed
- Nominal strength
- Nominal voltage and current of switches
- Ingress Protection
- Weight
- Operation lift
- CE mark

The servomotor lid includes the connection scheme.

DELIVERY

The servomotors are delivered with installed coupling for the connection to the pull-rod of the valve. The signalling switch SC is adjusted approx. 2 mm before the position "CLOSED" and signalling switch SO is adjusted approx. 2 mm before the position "OPEN" pursuant to the lift. Unless established otherwise, they are delivered with the lift 65 mm.

Every delivery includes, unless agreed otherwise with the customer:

- Delivery note
- Products pursuant to the purchase order
- Accompanying technical documentation in Czech:
 - o Product manual
 - o Manual for the control electronics DMS3
 - o Product quality and completeness certificate, which also serves as the warranty certificate
 - o Test report

If it is established in the purchase contract or agreed otherwise, the following documentation can be also delivered with the product

- EU Declaration of Conformity

RELIABILITY

The life expectancy is 6 years, however 3,000 operation cycles as a maximum for servomotors for remote control and 250,000 cycles of servomotors for automatic control with service time specified in technical documentation for any specific product.

PACKING

Both products and accessories are delivered in a packing ensuring resistance to the impact of thermal effects and mechanical effects pursuant to controlled packing regulations.

TRANSPORT

The servomotors may be transported on conditions corresponding to the set of combinations of the classes IE 21 pursuant to EN 60721-3-2. The servomotors can be transported by rail or vehicles. In case of air transport, transport in heated and hermetically closed parts of the airplane shall only be considered.

STORAGE

The servomotors may be stored in a transport package on conditions corresponding to the set of combinations of classes IE 11/1K pursuant to EN 60721-3-1.(i.e. in places with a temperature between -5 ° C and 45 ° C and a humidity of between 5% and 95%, with no special risk of attack by biological agents, with minor vibrations and not in the vicinity of sources of dust and sand.

ORDERING

The purchase order shall specify

- Name
- Product ordering number
- Specification (if there is any)
- Special design after an agreement with the manufacturer
- Number of pieces

PURCHASE ORDER EXAMPLE

Electric servomotor ZEPADYN 671
671 121 / OP1, S1, R1, ZD40
5 pcs

TABLE 1 - DESING OF ELECTRIC PULL ROD SERVOMOTOR – TYPE 671

SPECIFICATION		ORDERING NUMBER			
		671	x	x	x
Supply voltage AC	1/N/PE AC 230 V 50 Hz		1		
	AC 24 V 50 Hz		2		
Nominal strength [kN]	16			1	
	20			2	
Outlet part changeover speed [mm / min]	16				1
	25				2
	32				3
	50				4

Basic design: three-position position control, manual control, moment switches for positions O and C and end position switch, without transmitter and connecting elements.

TABLE 1 - ADDITIONAL ACCESSORIES OF ELECTRIC PULL ROD SERVOMOTOR

CODE	NAME	CONNECTION PURSUANT TO
OP1	position control 0 to 1 V, 0 to 10 V, 0(4) to 20 mA - without R2 and I1	
DMS3	position control - control unit DMS3	refer manual DMS3
ANP1	adapter with adjusting programme for servomotors with OP1	
S1	signalling switches SO and SC	
R1	1 resistance transmitter 100 Ω	
R2	2 resistance transmitters 100 Ω - without OP1, I1, C1	
I1	converter 4 to 20 mA – without R2, C1	
C1	capacity transmitter CPT1 – without R2 a I1	
T1	heating resistor	
P2	pitch 150, 2 columns M 20, M 20 × 1,5	Figure 1
P3	pitch 150, 2 columns M 20, M 16 × 1,5 or M10 x 1	
P4	pitch, 2 columns M 20, M 20 x 1,5	Figure 2
P5	pitch 150, 4 columns M 20, M 20 x 1,5 (DN200-DN300), connection P5 only with lift Z80	Figure 3
ZD	lift for valve - 12, 16, 20, 25, 32, 40, 52, 62, 80 mm, lift Z80 only for connection P5	

The specification code shall be identified behind the ordering number.

INSTALLATION AND CONNECTION

The servomotor shall be connected to the controlled equipment by means of a flange or columns. The type of connection is evident in the dimensional drawings 1 and 2.

CONNECTION OF THE SERVOMOTOR TO THE CONTROLLED EQUIPMENT

Design P2 pursuant to Figure 1:

Adapters of columns are screwed into the flange of the valves. Columns of servomotors are inserted into the adapters and cap nuts are tightened.

Design P3 pursuant to Figure 1:

Adapters of columns are screwed into the flange of the valves. Columns of servomotors are inserted into the adapters and cap nuts are tightened.

Design P4 pursuant to Figure 2:

Adapters of columns are screwed into the flange of the valves. Columns of servomotors are inserted into the adapters and cap nuts are tightened.

Design P5 pursuant to Figure 3

Adapters of columns are screwed into the flange of the valves. Columns of servomotors are inserted into the adapters and cap nuts are tightened.

SERVOMOTOR ADJUSTMENT

By means of the manual control, pull-rod of the servomotor is adjusted approx. 2 mm before the stop columns in the position CLOSED. Press the pull-rod of the valve to the position CLOSED, too.

The valve spindle is screwed into the coupling and secured with a nut. By means of the manual control, move to the valve seat repeatedly in order to verify if the moment switch switches off with respect to valve seat and not to stop columns.

ELECTRICAL CONNECTION

The electrical connection may be only realized by qualified workers

The lid of the servomotor is removed after releasing two nuts. After removing the lid, the terminal board is accessible for the connection of supply voltage, signalling switches and resistance position transmitter or converter 4 to 20 mA.

Connect the servomotor with a max. Ø 12 mm cable to the supply voltage until it is mechanically fastened to the controlled device and after adjustment. Connect the insulated Cu conductors with a total insulation resistance min. 10 MΩ, dimensioned according to ČSN 33 2000-4-43 with cross section max. 1,5 mm². The installation of the servomotor shall include a switch or a circuit breaker located close to the

equipment, which enables disconnecting the device from supply mains. After connecting the wire grommets properly seal them with a suitable material (e.g. Colorplaster). The connection scheme is illustrated in Figures 4 and 5.

THE OUTPUT SHAFT

Is adjusted by means of the wheel of manual control. Slide out the lever from the bottom of the box and turn it by 90°. The pin that is located there will ensure disconnecting the gearing. Push the manual wheel into the box. Before setting in automatic operation, slide the manual wheel out and return the pin at the bottom of the box to the groove.

ADJUSTMENT OF THE END POSITION SWITCH

The switch KPO is adjusted to the required lift after releasing the screws M2 by sliding inside the groove so that it trips at the required lift.

ADJUSTMENT OF SIGNALLING SWITCHES

The servomotor is adjusted gradually to the positions to be signalled. By moving inside the groove, after releasing the screw M2, ensure switching of the relevant switches.

ADJUSTMENT OF TRANSMITTER

The transmitter is adjusted by the manufacturer to the lift pursuant to the purchase order (62 mm unless specified otherwise).

If another lift is selected, perform the adjustment as follows:

- Move the bar with movement screw to the position CLOSED (distance 2 mm from the stop of the upper beam).
- Release screws M4 connecting the angle bar with transmitter, replace the toothed double-wheel determining the lift (it is delivered by the manufacturing plant), move it to ensure engagement with toothed comb and tighten the screws.
- Check the value of residue resistance; pursuant product manual Article METROLOGICAL DATA, if it does not comply, adjust it by turning the shaft of the potentiometer.
- Move the pull-rod to the position OPEN and inspect the value of residue resistance pursuant to preceding Article.

Wires of the transmitter circuit between the outlet and the terminal board shall be inserted into a PVC tube.

ADJUSTMENT OF RESISTANCE TRANSMITTER WITH CONVERTER 4 TO 20 MA

The converter is adjusted by the manufacturer to the lift pursuant to the purchase order. When changing the positions "C" and "O", follow the procedure described below:

Adjust the transmitter pursuant to the paragraph about the transmitter adjustment.

Connect milliammeter with accuracy 0.2 to the outlet from the sensor. After connecting supply voltage, allow temperature settlement of the sensor. After the settlement, the outlet current shall be 4 mA ± 80µA at the beginning of the shaft position and 20 mA ± 80µA at the end. Otherwise, adjust the initial and end positions of the shaft gradually and the corresponding currents 4 and 20 mA with trimmers; it is necessary to consider the fact that values influence each other. Repeat the adjustment until current at the beginning of the shaft position is 4 mA ± 80 µA and 20 mA ± 80 µA at the end or measure the current value at initial (I_{L0}) and end (I_{H0}) rotations of the shaft and calculate the new value I_{H1} for the end adjustment with the use of the formula (*). After the adjustment of this value with a trimmer "20 mA", turn the shaft to the initial position and adjust the value 4 mA with a trimmer "4 mA". Check the adjustment afterwards.

Unless the current is 4mA ± 80µA at the beginning of the shaft position and 20 mA ± 80µA at the end, repeat the adjustment.

$$*) I_{H1} = 16x I_{H0} / (I_{H0} - I_{L0})$$

I_{L0}.. Value of current at the initial rotation of shaft

I_{H0}.. Value of current at the end rotation of shaft

I_{H1}.. Calculated value of current for end rotation of shaft

ADJUSTMENT OF REVERSING

Normal direction of travel is set-up at the factory, i.e. that current is increased with increasing lift. When adjusting the opposite direction, remove the interconnecting pieces, turn them by 90 ° and insert them back, refer to the Figure. Then inspect or, as the case may be, adjust outlet current in both positions.

ADJUSTMENT OF REVERSING

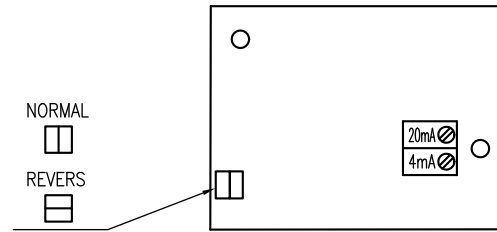

ADJUSTMENT OF POSITION CONTROL

The control is adjusted by the manufacturer to the nominal lift, inlet signal pursuant to purchase order, (if not specified, 4 to 20 mA) and movement to the end position in the direction of the signal in case of its loss.

In case of changes of these parameters, proceed as follows:

A change of the inlet signal for ranges starting with zero shall be realized by changing the location of interconnecting pieces pursuant to the table 3:

TABLE 2 - INSTALLATION OF INTERCONNECTING PIECES

Input signal	Jumpers
0 to 1 V	J1, J2
0 to 10 V	J2
0 to 20 mA	J1, J3
4 to 20 mA	J1, J3

LOCATION OF JUMPERS AND BUTTONS

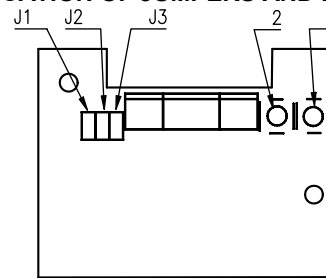

A change of the inlet signal to 4 to 20 mA or from 4 to 20 mA to signals starting with zero is realized by changing the location of interconnecting pieces pursuant to the table and follow-up calibration:

- connect the adjustable source of current or voltage signals;
- connect power supply;
- press push-buttons 1 and 2 for 5 sec., after their releasing LED diodes will start flashing concurrently (ADJUSTMENT mode);
- adjust the lower value of voltage or current on the source;
- move the servomotor by manual control to the lower position; both LEDs shall be flashing; flashing of only one LED signals reaching the end stop and a danger of overturning the position sensor; resistance value shall be increased by turning the potentiometer;
- press push-button 1 till the diode flashes (saving this position in memory);
- adjust the upper value of voltage or current on the source;
- move the servomotor by manual control to the upper position; both LEDs shall be flashing; flashing of only one LED signals reaching the end stop and a danger of overturning the position sensor; resistance value shall be decreased by turning the potentiometer;
- press push-button 2 till the diode flashes (saving this position in memory);
- press push-buttons 1 and 2 for 5 sec. (confirmation of set-up values to EEPROM memory);
- switch off and on power supply of the servomotor;
- adjust the lower value of voltage or current on the source, connect power supply and the servomotor shall move to the lower position;
- adjust the upper value of voltage or current on the source, connect power supply and the servomotor shall move to the upper position.

**WARNING**

During the adjustment, power supply may not be interrupted; otherwise the whole procedure shall be repeated!

A change of lift or a change of range of the inlet signal within 30 % of the relevant nominal range is realized according to the procedure described above with the required values of the inlet signal and lift.

In case of a change exceeding 30%, the transmitter shall be adjusted pursuant to the paragraph about adjustment of transmitter; the inspection of adjustment of end positions is pursuant to the flashing of diodes. The inlet signal is adjusted by the computer with the use of the adjustment programme.

By means of the application of the adjustment programme, the computer, which is connected to the controller by means of the adapter, can be used for the adjustment of:

- end positions
- lower insensitivity zone 2 to 5 %
- upper insensitivity zone 2 to 5 %
- temperature protection of motor
- type of action of the controller in case the pre-set range is exceeded by 5 % (open, close, without response, movement to the end position in the direction of the signal).

It is secured by the service of the manufacturing plant or the adjustment programme and an adapter to the computer (code ANP1) can be purchased.

ADJUSTMENT OF CAPACITY TRANSMITTER WITH CONVERTER

The servomotors with transmitter are adjusted to the lift pursuant to the purchase order. Unless specified otherwise, it is 62 mm. In case of another lift, the adjustment is performed as follows:

- The lift is adjusted pursuant to the paragraph about adjustment of transmitter (without inspection of residue resistance).
- Before the start of adjustment of the capacity transmitter, the area shall be found out where the current value is increasing with increasing lift.
- When this area has been found out, value 4 mA is adjusted in the position CLOSED by releasing the clips and mechanical rotating of the transmitter.
- The pull-rod of the servomotor is moved to the position OPEN and value 20 mA is adjusted by turning the trimmer, the shaft of which is led to the rear side of the transmitter by 90° from the inlet clamps (not in the axis of the transmitter). Screwdriver with width 3 mm shall be used for the adjustment. The trimmer has no stoppers; it cannot be damaged by overturning.
- If correction of current 20 mA is considerable, adjustment to 4 and 20 mA shall be repeated once more pursuant to the previous paragraphs. Using narrow sectors too often is not recommended, because additional errors occur relatively more often. The most suitable sectors are from 60 to 120°.

Wires of the transmitter circuit between the outlet and the terminal board shall be inserted into an insulation tube.

COMMISSIONING

After the installation on the controlled equipment, adjustment and connection to the supply voltage and PE terminals, the servomotor is prepared for operation.

**WARNING**

A failure to comply with the instructions specified in the Installation, operation and maintenance manual will result in faulty technical parameters and/or even failures of devices without any claim for warranty repairs whatsoever.

OPERATION AND MAINTENANCE

Manual control of the servomotor can be realized pursuant to Article – INSTALLATION AND CONNECTION, *THE OUTPUT SHAFT*.

At the factory, the movement screw is treated with sliding paint MOLYKOTE ensuring maintenance-free continuous lubrication for the whole period of service life and additional lubrication is made with grease MOLYKOTE 165 LT. Toothed wheels and bearings are lubricated with plastic grease MOGUL LV2 M (addition of molybdenum disulphide). After one year of permanent operation, it is recommended greasing the required places with the aforesaid greases.

SPARE PARTS

Spare parts shall be delivered by the manufacturer on the basis of a previous agreement.

WARRANTY

The warranty period is 24 months from the receiving of the product by the customer, unless established otherwise in the contract. Rejection of defects shall be enforced in writing at the manufacturer within the warranty period. The rejecting side shall identify the product name, ordering and manufacturing numbers, date of issue and number of the delivery note, clear description of the occurring defect and the subject of the claim. If the rejecting side is invited to send the device for repair, it shall do so in the original package of the manufacturer and/or in another package ensuring safe transport.

The warranty shall not apply to defects caused by unauthorized intervention into the device, its forced mechanical damage or failure to comply with operation conditions of the product and the product manual.

REPAIRS

The repairs shall be realized by the manufacturer. The device shall be sent for repair in the original or equal package without accessories.

DISABLING AND LIQUIDATION

The product and its package do not include any parts that could impact the environment.

Products that are withdrawn from operation, including their packages (with the exception of products marked as electrical equipment for the purposes of return withdrawal and separate salvage of electrical waste), may be disposed of to sorted or unsorted waste pursuant to the type of waste.

The manufacturer realizes free return withdrawal of marked electrical equipment (from 13.8.2005) from the consumer and points out the danger connected with their illegal disposal. The package of the servomotor can be recycled completely. Metal parts of the products are recycled, non-recyclable plastic materials and electrical waste shall be disposed of in accordance with applicable legislation.

FIGURE 1 - DIMENSIONAL DRAWING - CONNECTION P2 - COUPLING M20X1.5,
- CONNECTION P3 - COUPLING M16X1.5 or M10x1

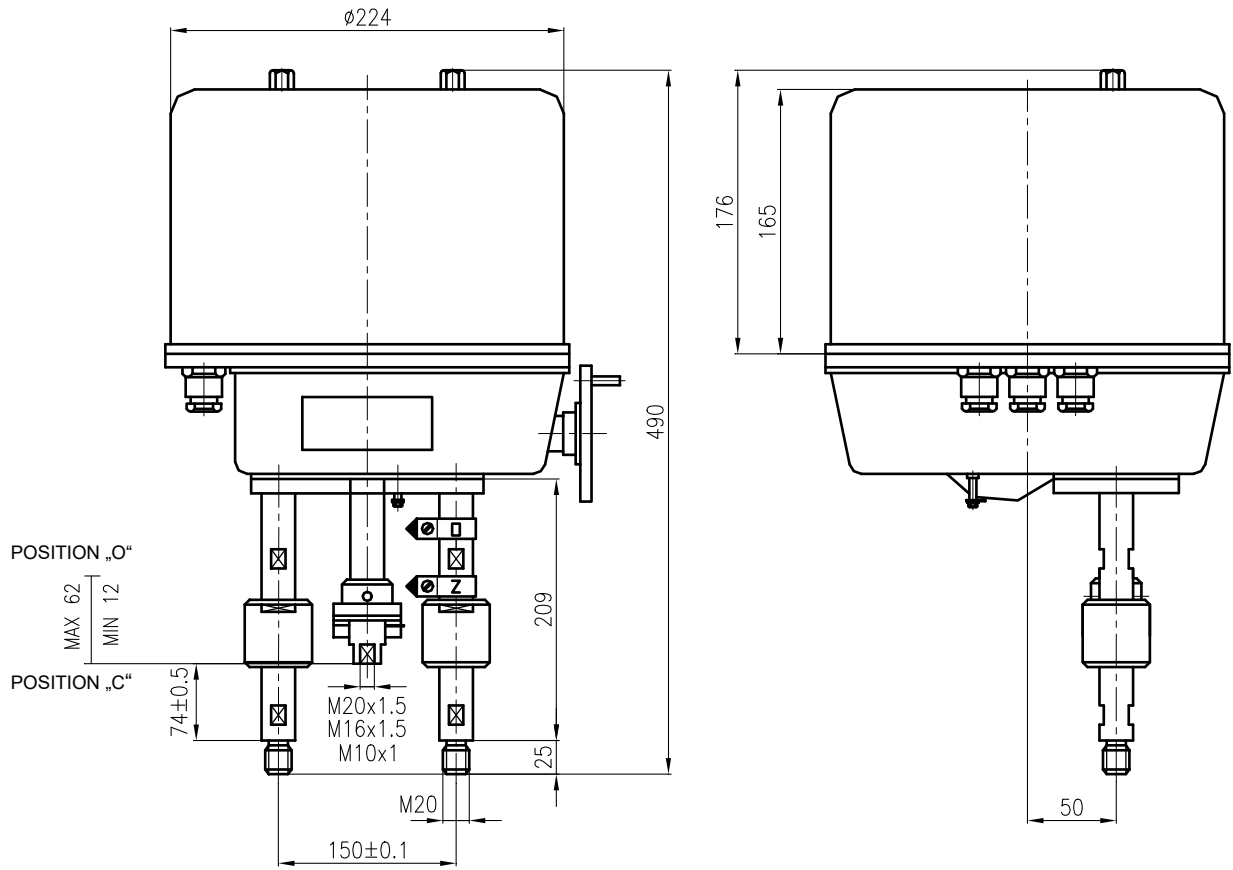

FIGURE 2 - DIMENSIONAL DRAWING - CONNECTION P4

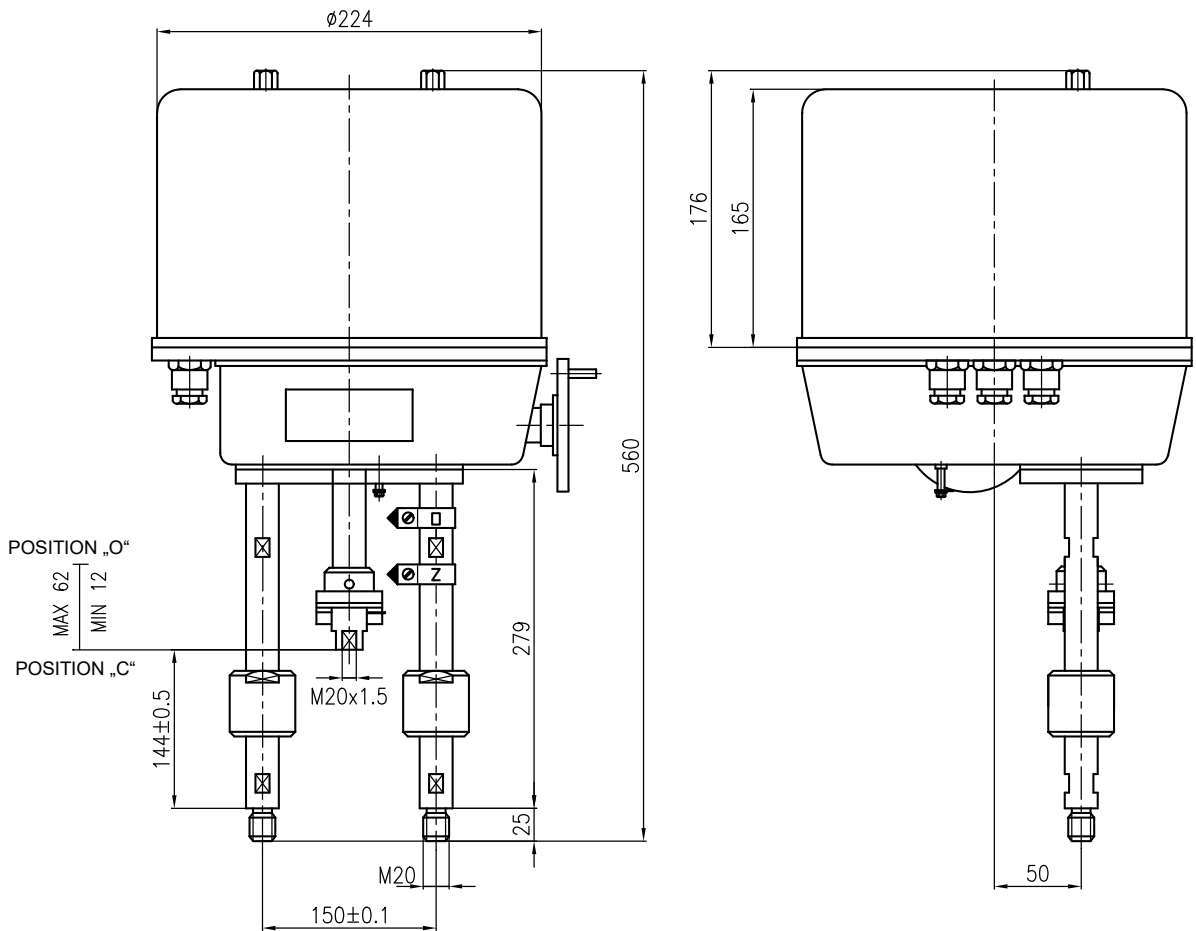

FIGURE 3 - DIMENSIONAL DRAWING - CONNECTION P5 - PITCH 150, 4 COLUMNS M 20, FITTING M20x1,5, LIFT 80

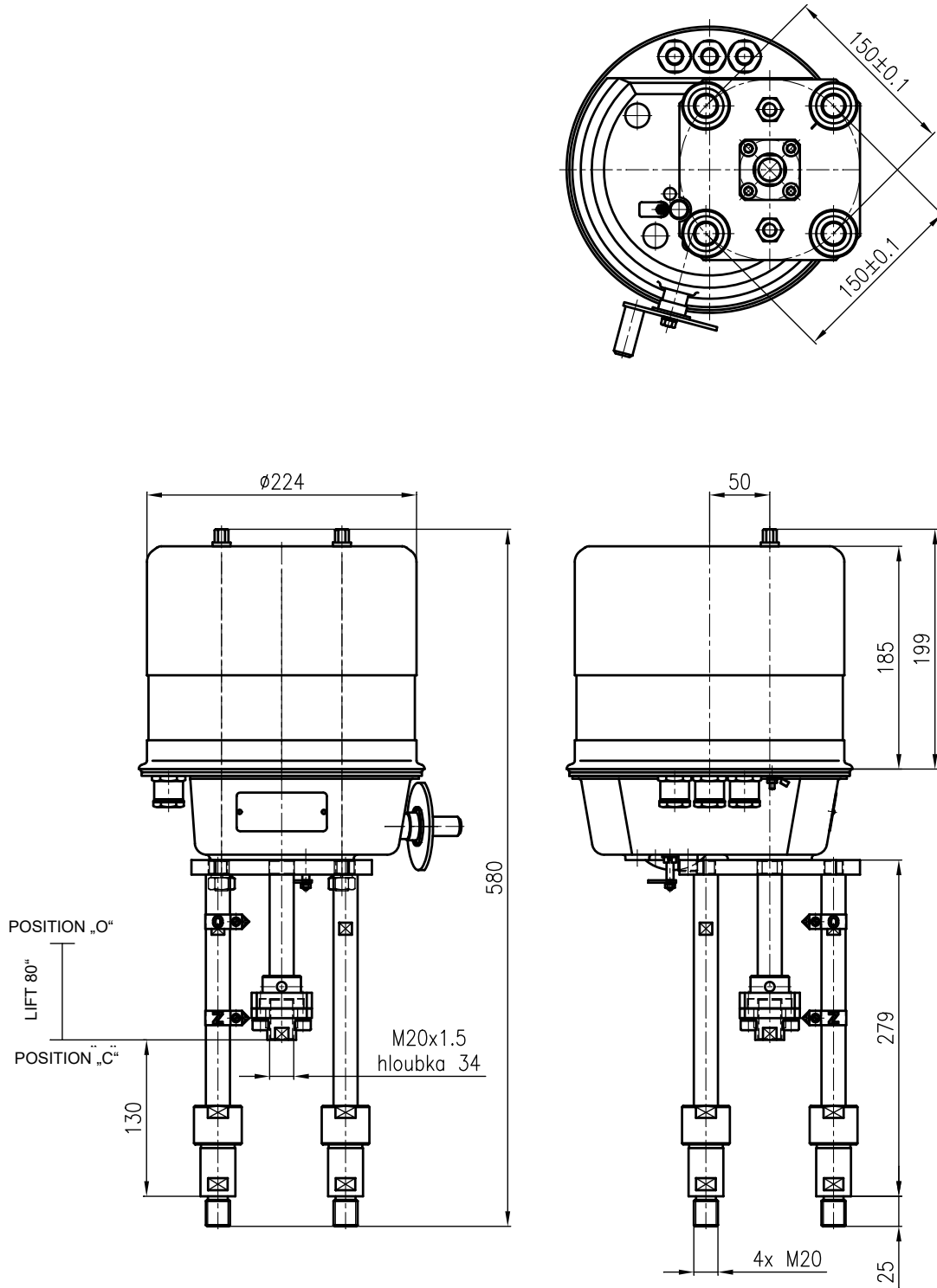
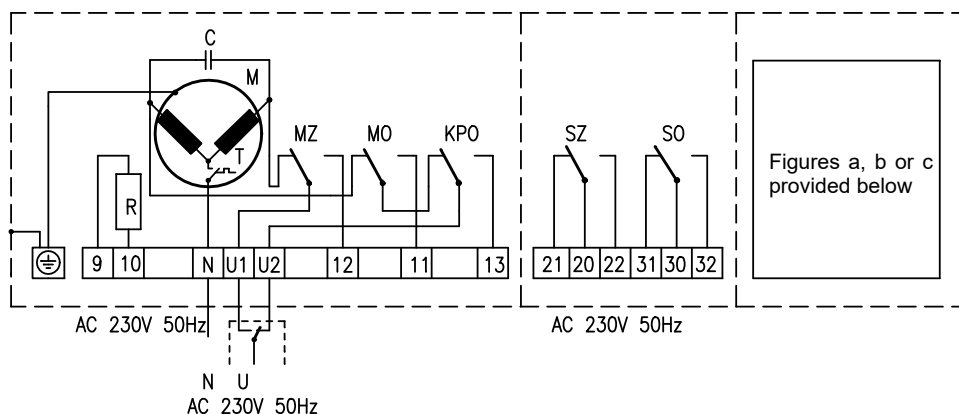

FIGURE 4 - CONNECTION SCHEME AND DRAWING OF TERMINAL BOARD

- a) Design with resistance transmitter
- b) Design with capacity position transmitter
- c) Design with converter 4 - 20 mA

CONNECTION SCHEME 230 V 50 Hz



CONNECTION OF TERMINAL BOARD 24 V 50 Hz

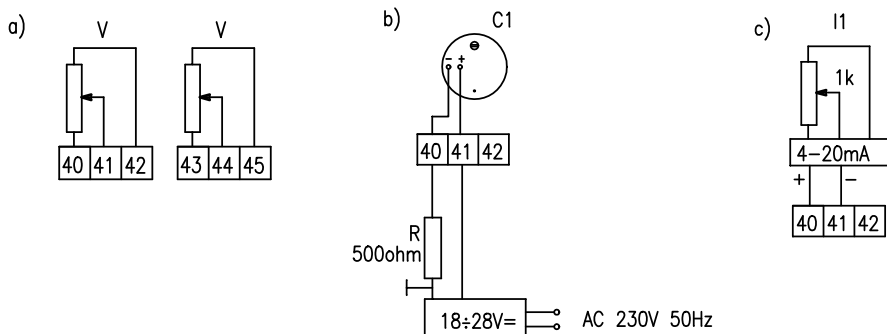
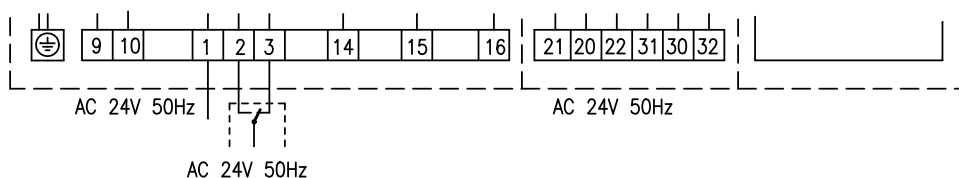

- KPO - end position switch for servomotor position O
- MO - strength switch for servomotor position "O"
- MC - strength switch for servomotor position "C"
- SO - strength signalling switch for servomotor position O
- SC - strength signalling switch for servomotor position C
- V - transmitter
- R - heating resistor
- M - motor
- T - thermal fuse
- C - condenser
- I1 - converter 4 ÷ 20 mA for two-wire connection to measuring loop (power supply directly from measured signal)
- C1 - capacity transmitter with converter 4 ÷ 20 mA

FIGURE 5 - CONNECTION SCHEME AND DRAWING OF TERMINAL BOARD – CONTROL 0-10 V, 0-20 mA, 4-20 mA

CONNECTION SCHEME 230 V 50 Hz

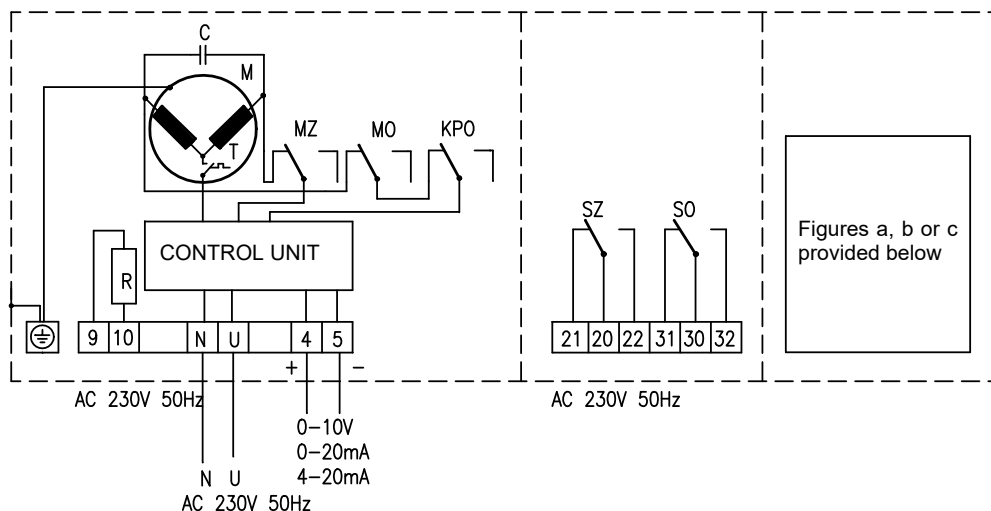

CONNECTION OF TERMINAL BOARD 24 V 50 Hz

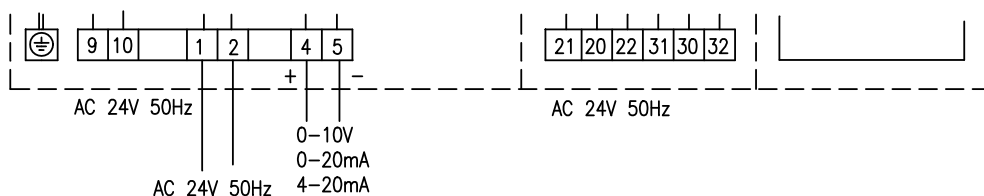

a)

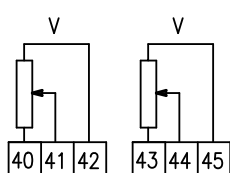

b)

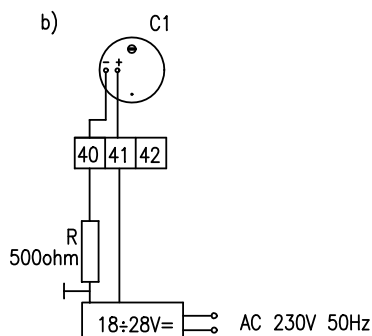

c)

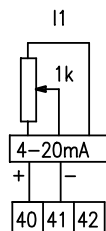

- KPO - end position switch for servomotor position O
- MO - strength switch for servomotor position "O"
- MC - strength switch for servomotor position "C"
- SO - strength signalling switch for servomotor position O
- SC - strength signalling switch for servomotor position C
- V - transmitter
- R - heating resistor
- M - motor
- T - thermal fuse
- C - condenser
- I1 - converter 4 ÷ 20 mA for two-wire connection to measuring loop (power supply directly from measured signal)
- C1 - capacity transmitter with converter 4 ÷ 20 mA

June 2018

© ZPA Nová Paka, a.s.

