

APPLICATION

- In measuring circuits of systems of industrial automation with higher temperature of the operation liquid;
- For fast complete closing or opening of flow of the operation liquid, which can flow through the ball valve in both directions; the recommended direction is identified with an arrow on the body;

The ball valves may not be used for regulating the flow; it concerns a closing full-flow armature.

DESCRIPTION

The basis of the valve consists of a body, in which the stop ball is located. With the use of a spindle, it is connected with handle to for manual control of the cock.

The positions of the ball valve "CLOSED" - "OPEN" (OFF-ON) are achieved by the movement of the handle to the stop.

Antistatic design of the ball valve ensures electric interconnection of all parts, which are in contact with the operation liquid and jacket (body) of the armature.

The ball valve design also ensures protection against possible pushing out of the control mechanism from the ball valve body. The ball valve in open position does not contain "dead areas", in which residue of operation liquids could remain or where their solid compounds could be deposited.

Flanges with weld-on optional inlet and outlet connecting terminals are screwed to the body.

The ball valves are also made with the design with extended spindle; these ball valves are suitable for the installation into the piping with reinforced insulation.

The stop element of the armature (ball) revolves around its axis that is vertical to the direction of flow and in the open position, the operation liquid flows through the ball valve.

The ball valve is closed (opened) by turning the handle to the right (left) by 90° up to the stop, which results in full closure or opening of the ball valve.

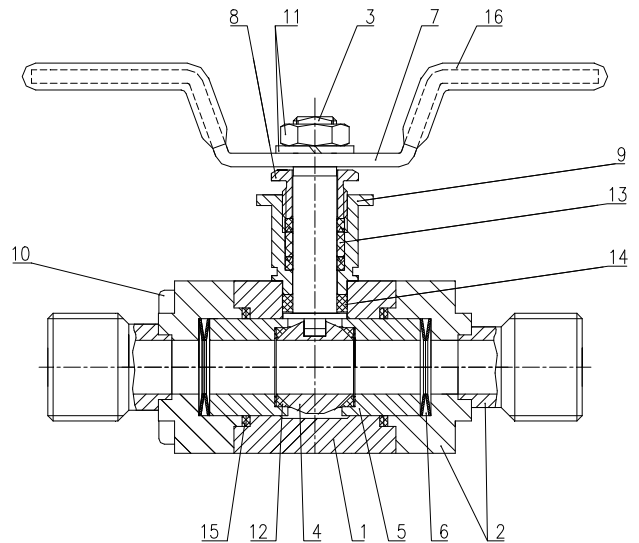

TABLE OF APPLIED MATERIALS

Position	Name of part	Material	
1	body	1.4541 *	
2	flanges and terminals	1.4541 *	
3	spindle	1.4541 *	
4	ball	AISI 316Ti *	
5	thrust pistons	1.4541 *	
6	disc spring	for 220 °C	1.4310
		for 300 °C	1.4122
7	handle	1.4541 *	
8	nut of seal	1.4541 *	
9	shaft bush	1.4541 *	
10	screws	stainless steel A2	
11	nut, washer	stainless steel A2	
12	seat	for 220 °C	PEEK+PTFE
		for 300 °C	DURATRON
13	seal	for 220 °C	PEEK+PTFE
		for 300 °C	GRAPHITE
14	spindle sealing	for 220 °C	PEEK
		for 300 °C	GRAPHITE
15	sealing of piston and flange	GRAPHITE	
16	handle roll-on	for 220 °C	VINYL
		for 300 °C	high temperature colour paint

*) The manufacturer has the relevant certificate 3.1 for these materials pursuant to EN 10204

TECHNICAL DATA

Nominal inner diameter acc.to EN ISO 6708 : DN 10

Nominal pressure acc to EN 1333: PN 63

Operation position: discretionary

Weight:

direct ball valve approx. 0.6 kg
direct ball valve with extended spindle approx. 0.7 kg

Type of operation: continuous

Connection to piping: optional input and output connecting terminals

Quality of welds: acc. to EN ISO 5817-C

OPERATION CONDITIONS

Ball valves are designed for the environment defined by the group of parameters and their severity grades IE36 pursuant to standard EN 60721-3-3 and the following operation conditions.

Maximum operation temperature:

220 °C - with sealing from material PEEK

300 °C - with sealing from material GRAPHITE + DURATRON

Operation liquid: technical water, petrol, kerosene, crude oil, circulation oil (H₂) and others

CHEMICAL RESISTANCE OF SEALING MATERIALS

Chemical resistance of materials of sealing elements represents an important parameter, which determines reliability of the valve. The following table includes informative data of the most frequently used substances together with chemical resistance of sealing element materials. If other substances are used, chemical resistance tests shall be performed directly at the customer in the expected operation conditions (temperature, pressure, concentration ...)

Medium		GRAPHITE	PTFE	PEEK	DURATRON	
Acetone		+	+	+	+	
Acetylene		+	+	+		
Petrol		+	+	+	+	
Ammonia	aqueous solution	+	+	+		
	liquid	+	+			
	gaseous	+	+			
Ethylene		+	+			
Hydraulic fluids	not flammable	+	+	+		
Hydroxides		+	+	+		
ACIDS	Boric		+			
	Citric		+	+	+	
	Nitric		+	+	-	-
	Hydrofluoric	< 65%	+	+		
		> 65%		+		
	Phosphoric	10%	+	+	-	-
		concentrate		+	-	-
		boiling conc.		+	-	-
	Hydrochloric	10%, 80°C		+		-
		36%, 20°C		+		-
	Chromic			+		
	Malic			+		
	Carbolic			+		
	Hydrocyanic			+		
	Butyric			+		
	Lactic			+		
	Formic	10%	+	+	-	-
	Acetic	10%	+	+		*
		concentrate		+		
	Salicylic			+		
Sulphuric	25%	+	+		*	
	80%	+	+			
Oxalic	10%		+			
Carbonic			+			
Tartaric		+	+		+	
Oxygen		+	+	+	+	
Oils		+	+	+	+	
Steam	< 200°C	+	+	+	+	
	> 200°C	+	-		+	
Perchloroethylene		+	+	+		
Kerosene		+	+	+	+	
Gaseous fuels		+	+	+	+	
Radioactive radiation		*	-	+	+	
Compressed air		+	+		+	
Toluene, trichloroethylene		+		+	+	
Hydrocarbons		+	+		+	
Water	< 80°C	+	+	+	+	
	> 80°C	+	+	+	+	
Hydrogen	cold	+	+	+	+	
	hot	+	+	+	+	

- + Great resistance
- Not resistant
- * Good or conditional resistance
- Vacant No information is available

DESIGNATION

(pursuant to ČSN 13 3005-1)

Data on ball valve body

- Trade mark of the manufacturer
- Product ordering number
- Time code (serial number)
- Nominal inner diameter
- Nominal pressure
- Maximum operation temperature
- Body material
- Casting number of body material
- Mark of performed pressure test
- Code of spindle and seat seal sealing
- Arrow indicating recommended direction of medium flow

Data on ball valve handle

- Arrows and terms OFF – ON identifying direction of CLOSING – OPENING the cock

DELIVERY

Unless agreed otherwise with the customer, each delivery includes

- Delivery note
- Products pursuant to the purchase order
- Accompanying technical documentation in Czech:
 - o Product quality and completeness certificate, which also serves as the warranty certificate
 - o Test report and list of used materials
 - o Product manual

If it is established in the purchase contract or agreed otherwise, the following documentation can be also delivered with the product:

- Copy of inspection certificate 3.1 pursuant to EN 10204 for body material and other parts according to the table of used materials with casting number
- Declaration of Conformity with purchase order 2.1 pursuant to EN 10204
- Supplier's declaration of conformity in accordance with ISO/IEC 17050-1
- Test report about the seismic and the vibration qualification

PLACING AN ORDER

The purchase order shall specify:

- Name
- Product ordering number
- Other (special) requirements
- Number of pieces

PURCHASE ORDER EXAMPLE

Standard design:

1. Ball valve PN 63 for high temperatures
973 11 15 15 W4 BM1
20 pcs
2. Ball valve PN 63 for high temperatures
973 11 15 21 W6 BZ1 K KU5
20 pcs

Special requirement:

- Ball valve PN 63 for high temperatures
973 71 99 99
5 pcs

TABLE 1 - DESIGN OF BALL COCKS, TYPE 973

SPECIFICATIONS		ORDERING NUMBER								
		973	x	1	xx	xx	xx	xxx	xxx	xxx
DESIGN OF BALL VALVE	direct		1	1						
	direct with extended spindle		7	1						
CONNECTING TERMINALS pursuant to table 2	OF INLET				xx					
	OF OUTLET					xx				
SEALING OF SEAL, SPINDLE AND SEAT	seal from PEEK (resistant to gamma radiation) (max. 220°C)						W6			
	sealing of seal - GRAPHITE + 1.4541						W8			
	sealing of spindle - GRAPHITE									
	sealing of seat - DURATRON (max. 300°C)									
COLOUR OF HANDLE ROLL-ON	green							BZ1		
	red							BR1		
	blue							BM1		
	yellow							BY1		
ACCESS CODE pursuant to table 3 ¹⁾	of inlet								xxx	
	of outlet									xxx

¹⁾ If the code is not specified, the fitting will be supplied without special modifications and without accessories

TABLE 2 - OVERVIEW OF CONNECTING TERMINALS

All specified connecting terminals (with the exception of terminals with codes 31, 35 and 37) are designed for full flow-through with nominal inner diameter DN 10.

CODE	DRAWING	INSTALLATION PROCEDURE OF CONNECTING TERMINALS WITH THREADED RINGS
14		<p>By means of a cap nut and two rings, a drawn, seamless tube made of plain carbon steel, alloy steel or stainless steel with Ø 6, 8, 10, 12, 14, 16, 18, 20 a 22 mm with tolerance of outside diameter and ovality ± 0.3 mm can be connected in a way that enables further uninstallation.</p> <p>FIRST INSTALLATION:</p> <ol style="list-style-type: none"> Slide the cap nut, rear (cylindrical) ring and front (conical) ring on the straight-cut end of the tube that is free of burrs – pay attention to its orientation! To ensure correct function, it is necessary to maintain the layer of grease applied by the manufacturer on the conical sealing surface, rear ring and threads! Insert the end of the tube with rings into connecting sleeve up to the bottom and tighten the cap nut by hand. Tighten the cap nut with a torque-limiting wrench with the following torque 60 Nm (for tube Ø 12 mm) or 65 Nm (for tube Ø 14 mm).
15		<p>UNINSTALLATION + REPEATED INSTALLATION:</p> <ol style="list-style-type: none"> Uninstallation shall be realized by complete unscrewing of the cap nut <u>after pressure has been completely discharged from the system.</u> Before repeated installation, check cleanness of the tube, threads and all sealing surfaces and pay attention to any possible damage. Rotation of the front threaded ring on the tube is not a defect! To ensure correct function, it is suitable to maintain the layer of grease applied by the manufacturer on the conical sealing surface, rear ring and threads; otherwise, they should be greased again. If required, this original grease can be ordered at the manufacturer of the armature. The installation is realized by inserting the end of the tube with rings and cap nut up to the bottom of the connecting sleeve. Tighten the cap nut by hand. By means of a torque wrench, tighten the nut by torque for repeated installation, i.e. 53 Nm (for tube Ø 12 mm) or 55 Nm (for tube Ø 14 mm). <p>WARNING: <u>THE CAP NUT MAY NEVER BE TIGHTENED (RELEASED) UNDER PRESSURE – it could cause lethal injury!!!</u></p> <p>A failure to comply with the aforesaid torque (i.e. insufficient or excessive tightening of the cap nut) during the installation and with the minimum straight part of the tube from its end results in decreasing resistance of the connection to pressures and vibrations, which could then cause leakage of the connection.</p> <p>If vibrations of the piping system occur, the armature to be connected shall be fixed by means of a suitable holder and the connecting piping shall be attached in certain distances by tube fittings.</p>

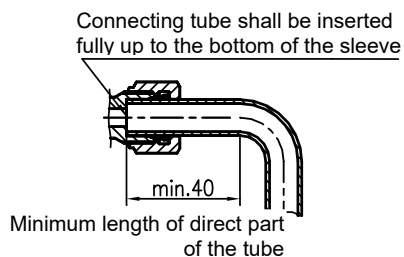
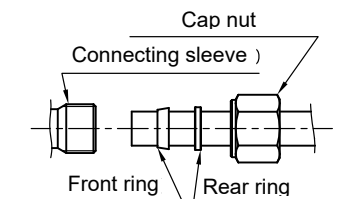
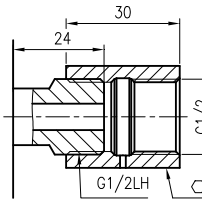
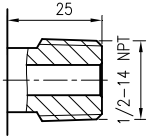
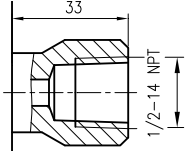
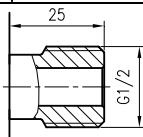
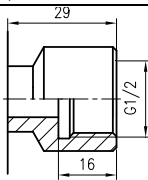

TABLE 2 - OVERVIEW OF CONNECTING TERMINALS – continuation from the previous page

CODE	DRAWING	DESCRIPTION AND INSTALLATION PROCEDURE
21		<p style="text-align: center;">SCREW-JOINT FOR CONE</p> <ol style="list-style-type: none"> Put a cap nut on the cone Weld the cone on the tube end By means of a nut, screw the tube to the sleeve, hold the cock flange with side wrench 32 and tighten the nut with torque of 120 Nm.
22		<p style="text-align: center;">WELD-ON CONE WITH CAP NUT M20x1.5</p> <p>By means of the nut, screw the armature to the screw joint for a cone, which forms a part of e.g. condensation tank, another valve, etc., hold the cock flange with a side wrench 32 and tighten the nut with torque of 120 Nm.</p>
23		<p style="text-align: center;">WELD-ON CONE WITH CAP NUT M22x1.5</p> <p>By means of the nut, screw the armature to the screw joint for a cone with the corresponding thread, which forms a part of e.g. piping, hold the cock flange with a side wrench 32 and tighten the nut with torque of 150 Nm.</p>
31		<p style="text-align: center;">MANOMETRIC SCREW-JOINT M20x1.5</p> <ol style="list-style-type: none"> Put a cap nut on the sleeve Weld the sleeve on the tube end Put a metal sealing on the screw joint By means of a nut, screw the piping to the screw joint, hold the cock flange with side wrench 32 and tighten the nut with torque of 120 Nm.
32		<p style="text-align: center;">WELD-ON SLEEVE WITH CAP NUT M20x1.5</p> <p>By means of a nut, screw the armature to the manometric screw joint with the corresponding thread, hold the cock flange with side wrench 32 and tighten the nut with torque of 120 Nm.</p>
33		<p style="text-align: center;">SCREW-JOINT WITH MANOMETRIC CONNECTION M20x1.5 LH / M20x1.5</p> <p>The screw joint is used to connect a manometer or valve with this screw joint.</p> <ol style="list-style-type: none"> Put a metal sealing on the screw joint of the manometer. Screw the manometer and the armature together with the use of a sleeve coupling (it is delivered with the armature), hold the cock flange with side wrench 32 and tighten the nut with torque of 120 Nm.
34		<p style="text-align: center;">TEST SCREW-JOINT M20x1.5</p> <p>The screw joint is used to connect control manometer. It is delivered including the plug with sealing. Recommended torque is 120 Nm.</p>
35		<p style="text-align: center;">MANOMETRIC SCREW-JOINT G1/2</p> <ol style="list-style-type: none"> Put a cap nut on the sleeve Weld the sleeve on the tube end Put a metal sealing on the screw joint By means of a nut, screw the piping to the screw joint, hold the cock flange with side wrench 32 and tighten the nut with torque of 120 Nm.
36		<p style="text-align: center;">WELD-ON SLEEVE WITH CAP NUT G1/2</p> <p>By means of a nut, screw the armature to the manometric screw joint with a corresponding thread, hold the cock flange with side wrench 32 and tighten the nut with torque of 120 Nm.</p>
37		<p style="text-align: center;">WELD-ON SLEEVE WITH CAP NUT M20x1.5 WITH SEALING PURSUANT TO STANDARD SHELL</p> <p>By means of a nut, screw the armature to the manometric screw joint, hold the cock flange with side wrench 32 and tighten the nut with torque of 120 Nm. Tightness is ensured with stainless sealing ring made of soft steel.</p>
39		<p style="text-align: center;">SCREW-JOINT WITH MANOMETRIC CONNECTION M20x1.5 LH / G1/2</p> <p>The screw joint is used to connect a manometer or valve with manometric screw joint G1/2.</p> <ol style="list-style-type: none"> Put a metal sealing on the screw joint of the manometer. Screw the manometer and the armature together with the use of a manometric connection (it is delivered with the armature), which shall be tightened with torque of approx. 120 Nm.

TABLE 2 - OVERVIEW OF CONNECTING TERMINALS – continuation from the previous page

CODE	DRAWING	DESCRIPTION AND INSTALLATION PROCEDURE
40		<p>SCREW-JOINT WITH MANOMETRIC CONNECTION G1/2 LH / G1/2</p> <p>The screw joint is used to connect a manometer or valve with manometric screw joint G1/2.</p> <ol style="list-style-type: none"> Put a metal sealing on the screw joint of the manometer. Screw the manometer and the armature together with the use of a manometric connection (it is delivered with the armature), which shall be tightened with torque of approx. 120 Nm.
42		<p>EXTERNAL THREAD 1/2 - 14 NPT</p> <ol style="list-style-type: none"> Wind up sealing tape of PTFE on the thread. Screw the armature into the hole with corresponding internal thread, hold the cock flange with side wrench 32 and tighten the nut with torque of 120 Nm.
54		<p>INTERNAL THREAD 1/2 - 14 NPT</p> <p>The thread is cut in the weld-on terminal.</p> <ol style="list-style-type: none"> Wind up sealing tape of PTFE on a corresponding external thread Screw the screw joint or tube into the hole in the armature, hold the cock flange with side wrench 32 and tighten the nut with torque of 120 Nm.
62		<p>EXTERNAL THREAD G1/2</p> <p>Wind up sealing tape of PTFE on the thread. Hold the cock flange with side wrench 32 and tighten the nut with torque of 120 Nm.</p>
72		<p>INTERNAL THREAD G1/2</p> <p>The thread is cut in the weld-on flange.</p> <ol style="list-style-type: none"> Wind up sealing tape of PTFE on a corresponding external thread Screw the screw joint or tube into the hole in the weld-on terminal Hold the cock flange with side wrench 32 and tighten the nut with torque of 120 Nm.
99		ANOTHER CONNECTING TERMINAL

ORDERING ACCESSORIES

The purchase order shall specify:

- Name
- Product ordering number
- Number of pieces

PURCHASE ORDER EXAMPLE

Standard design:

1. Weld-on sleeve with cap nut and sealing
981 NA1
20 pcs
2. Sealing3
972 11 15 21 W1 BZ1 KKU5
20 pcs

TABLE 3 OVERVIEW OF OPTIONAL ACCESSORIES

CODE	WELD-ON CONE WITH CAP NUT		
	MATERIAL	INNER DIAMETER	DRAWING
KU1	Carbon steel	1.0569	
KU2	Stainless steel	1.4541	
KU3	Creep-resisting steel	15 128	
KKU4	Carbon steel	1.0569	
KKU5	Stainless steel	1.4541	
KKU6	Creep-resisting steel	15 128	
CAP NUT FOR WELD-ON CONE			
MATERIAL OF NUT	DRAWING OF NUT		DRAWING OF SCREW-UNION
Stainless steel 1.4541 (only for KU2, KU3, KKU5 and KKU6)			
Carbon steel 11 109.0 (only for KU1 and KKU4)			

TABLE 4 OVERVIEW OF OPTIONAL ACCESSORIES

CODE	WELD-ON SLEEVE WITH CAP NUT AND SEALING					
	The sleeve is delivered by 1 piece, welded in a PE bag together with the relevant cap nut and aluminium sealing. After putting the cap nut on the sleeve and welding the sleeve on the piping, it is possible to connect an armature, which is provided with a corresponding screw-union for the sleeve according to the dimensional drawing of the screw-union, to the piping.					
	MATERIAL OF SLEEVE		THREAD OF NUT	SLEEVE		
			INNER DIAMETER	DRAWING		
NA1	Carbon steel	1.0569	M20 x 1.5	6.5		
NA2	Stainless steel	1.4541				
NA3	Creep-resisting steel	15 128				
NAG1	Carbon steel	1.0569	G 1/2		6.5	
NAG2	Stainless steel	1.4541				
NAG3	Creep-resisting steel	15 128				
NA4	Carbon steel	1.0569	M20 x 1.5	6.5		
NA5	Stainless steel	1.4541				
NA6	Creep-resisting steel	15 128				
NAG4	Carbon steel	1.0569	G 1/2		6.5	
NAG5	Stainless steel	1.4541				
NAG6	Creep-resisting steel	15 128				
CAP NUT FOR WELD-ON SLEEVE						
MATERIAL OF NUT		DIMENSIONAL DRAWING OF NUT		DRAWING OF SCREW-UNION		
Stainless steel 1.4541 (only for NA2, NAG2, NA3, NAG3, NA5, NAG5, NA6 and NAG6)						
Carbon steel 11 109.0 (only for NA1, NAG1 NA4 and NAG4)						
SEALING RINGS FOR WELD-ON SLEEVE						
Sealing rings made of other materials can also be ordered independently according to the following ordering numbers						
ORDERING NUMBER	MATERIAL OF SEALING			DRAWING OF SEALING		
382 041	Al	EN AW-1050A				
276 067	Cu	42 3005				
382 063	Stainless steel	1.4541				
382 096	Stainless steel	1.4404				

Optional accessories according to Table 3 can also be ordered separately as Type 981 (according to Accessory Catalog 981).

Figure 1 - Ball cock - direct (973 11 ..), dimensional drawing

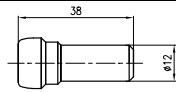
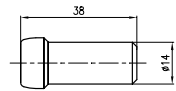
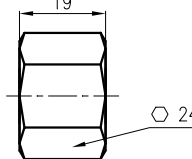
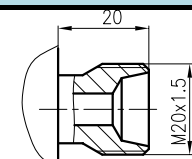
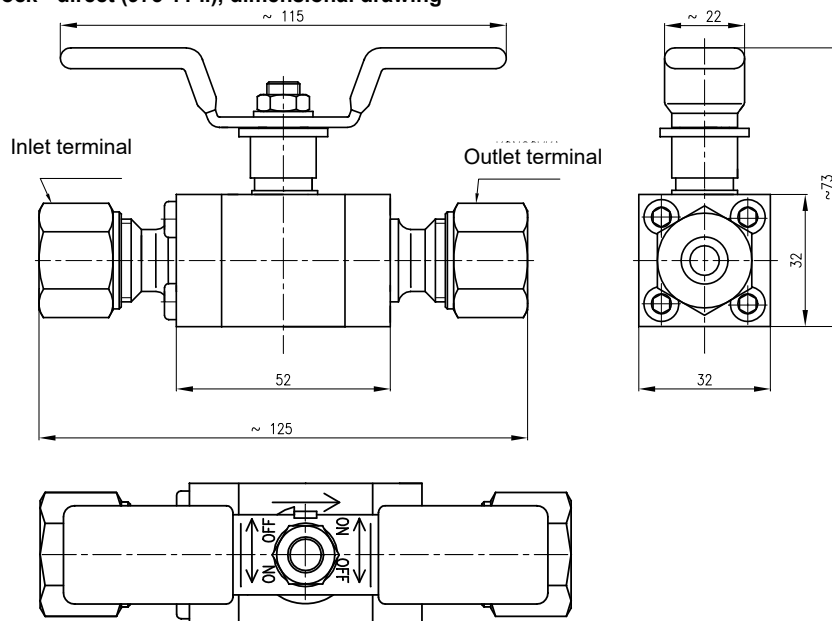
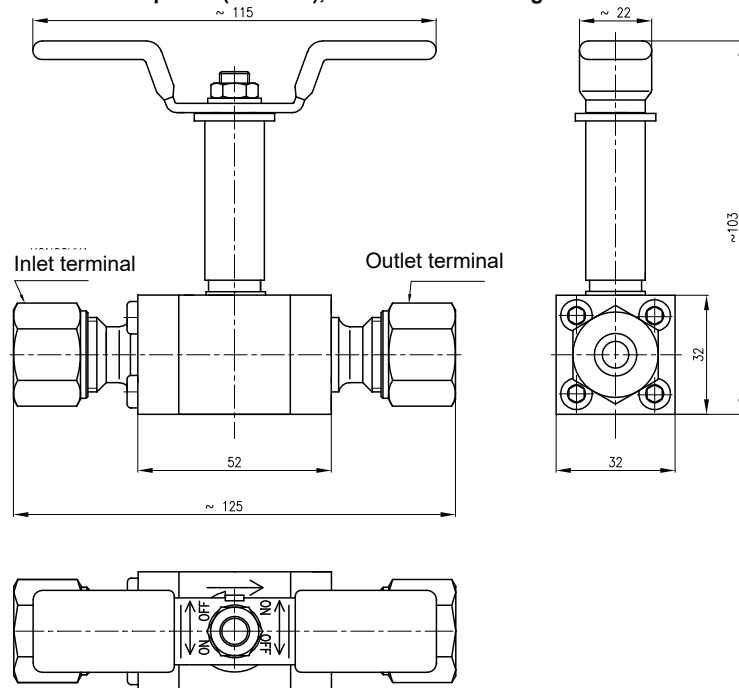

Figure 2 Ball cock – direct with extended spindle (973 71 ..), dimensional drawing



PACKING

Both products and accessories are delivered in a packing ensuring resistance to the impact of thermal effects and mechanical effects pursuant to controlled packing regulations.

TRANSPORT

The products may be transported on conditions corresponding to the set of combinations of classes IE 23 pursuant to EN 60721-3-2 but they may not be exposed to direct rain (i.e. by plains, trucks, trailers and semi-trailers, railway wagons with specially designed shock absorbers and ships, in premises that are without ventilation and protection against climatic effects).

STORAGE

The products may be stored on conditions corresponding to the set of combinations of classes IE 12 pursuant to EN 60721-3-1 but with ambient temperature from -30 to 45 °C (i.e. in places, where temperature and humidity are not regulated, with a threat of occurrence of condensation, dripping water and formation of ice, without a special threat of an attack with biological agents, with vibrations of small significance and not situated close to sources of dust and sand).

INSTALLATION AND CONNECTION

The ball valve installation may be realized by a worker of the installation or service organization.

The operation liquid may flow through the ball valve in both directions. The arrow in the upper part of the body indicating the recommended direction of flow only serves for identification of inlet and outlet terminals in case they are different.

Installation of the ball valve shall be realized directly on the piping by means of inlet and outlet connecting terminals.

The procedure of correct connection of the terminals with threaded rings is specified on the instruction label, which forms a part of the delivery of the ball valve.

COMMISSIONING

After the installation (connection of the piping) and inspection of the correct position of the control handle, the ball valve is prepared for operation.

OPERATION AND MAINTENANCE

The ball valve is closed (opened) by turning the handle to the right (left) by 90° to the stop, which results in full closure or opening of the ball valve. The positions of the ball valve "CLOSED" - "OPEN" (OFF-ON) are achieved by the movement of the handle to the stop. Intermediate positions are not recommended on principle – danger of damaging seats and losing tightness.

The ball valve may only be cleaned by service workers of the manufacturer.

PROCEDURE IN CASE OF FINDING LEAKAGE OF THE CONNECTION WITH THREADED RINGS

Possible leakage of the connection can be caused by unauthorized installation, e.g. by failure to comply with required torque (i.e. excessive or insufficient tightening of the cap nut), failure to comply with the minimum direct part of the tube from its end or application of this connection in conditions with increased level of vibrations without any fixation of the armature and connecting tubes, especially of those of bigger lengths.



WARNING

The cap nut may never be tightened (released) under pressure – it could cause lethal injury !!!

Uninstallation and repeated installation of the connection shall be realized pursuant to table 2 - INSTALLATION PROCEDURE FOR CONNECTING TERMINALS WITH THREADED RINGS.

RELIABILITY

Reliability indicators in the operating conditions and environmental conditions in this manual

- Mean operating time between failures of	96,000 hours (inf.value)
-the estimated life span of	10 years

SPARE PARTS

The ball valve design does not require any delivery of spare parts.

WARRANTY

The warranty period is 36 months from the receiving of the product by the customer, unless established otherwise in the contract. The manufacturer warrants for the parts, which are subjected to natural wear and are replaceable as a part of common maintenance of the product (seal sealing, sealing rings, etc.), for the period of 24 months.

Rejection of defects shall be enforced in writing at the manufacturer within the warranty period. The rejecting side shall identify the product name, ordering and manufacturing numbers, date of issue and number of the delivery note, clear description of the occurring defect and the subject of the claim. If the rejecting side is invited to send the device for repair, it shall do so in the original package of the manufacturer and/or in another package ensuring safe transport.

The warranty shall not apply to defects caused by unauthorized intervention into the device, its forced mechanical damage or failure to comply with operation conditions of the product and the product manual.

REPAIRS

The ball valves shall be repaired by the manufacturer. They shall be sent for repair in the original or equal package without accessories.

DISABLING AND LIQUIDATION

The product and its package do not include any parts that could impact the environment.

Products that are withdrawn from operation (including their packages) may be disposed of to sorted or unsorted waste pursuant to the type of waste.

The package of the product can be recycled completely. Metal parts of the product are recycled, non-recyclable plastic materials shall be disposed of in accordance with applicable legislation



NOVÁ PAKA

ZPA Nová Paka, a.s.
Pražská 470
509 39 Nová Paka

tel.: spojovatel: 493 761 111
fax: 493 721 194
e-mail: obchod@zpanp.cz

www.zpanp.cz
bankovní spojení: ČSOB HK
číslo účtu: 271 992 523/300

IČO: 46 50 48 26
DIČ: CZ46504826